

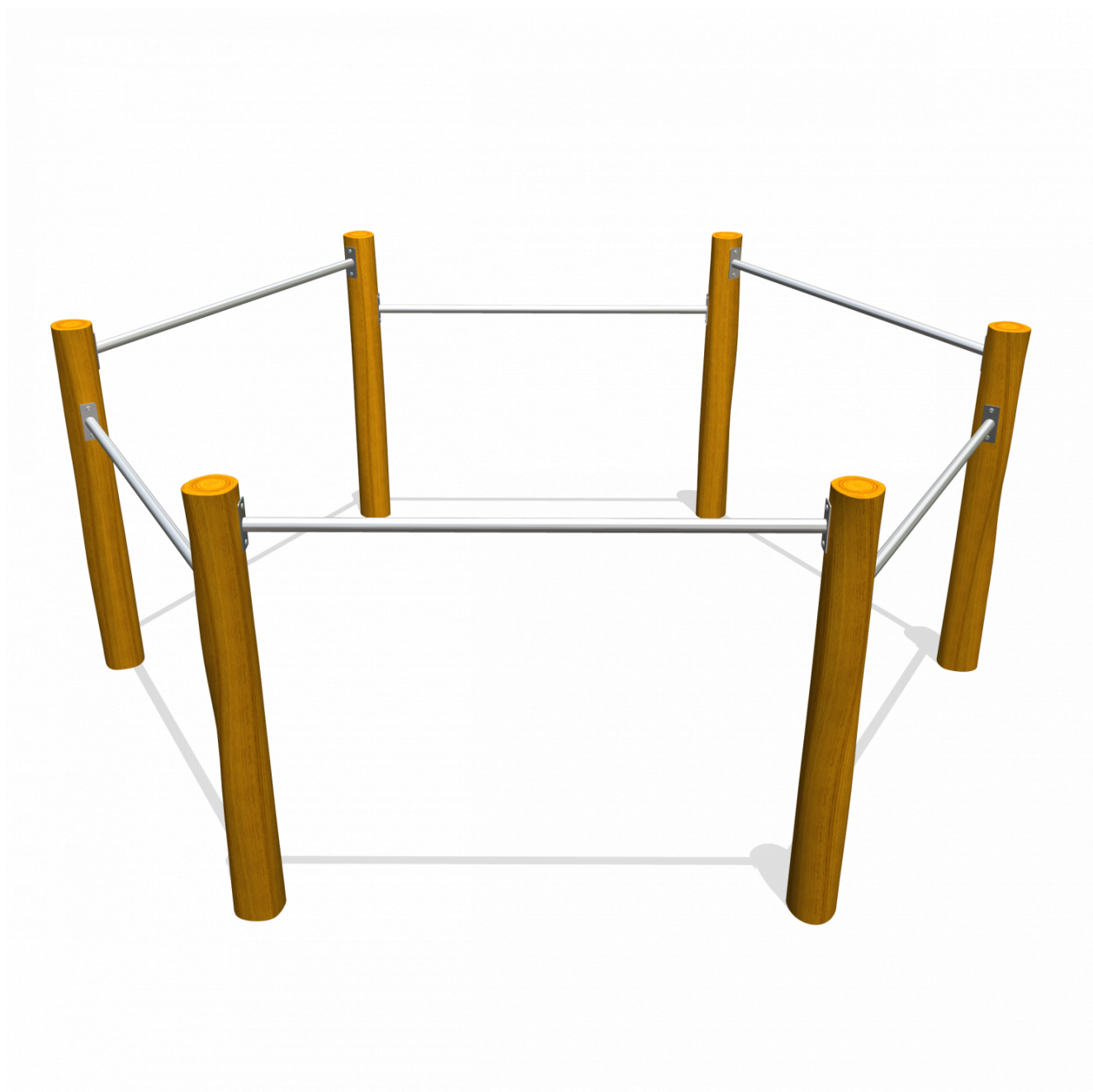

Tumble bar hexagon



PSTE000.084

Staander afvlakken zodat kopplaat duikelstang geheel tegen staander komt. Uitstekende delen < 8mm. (12x)

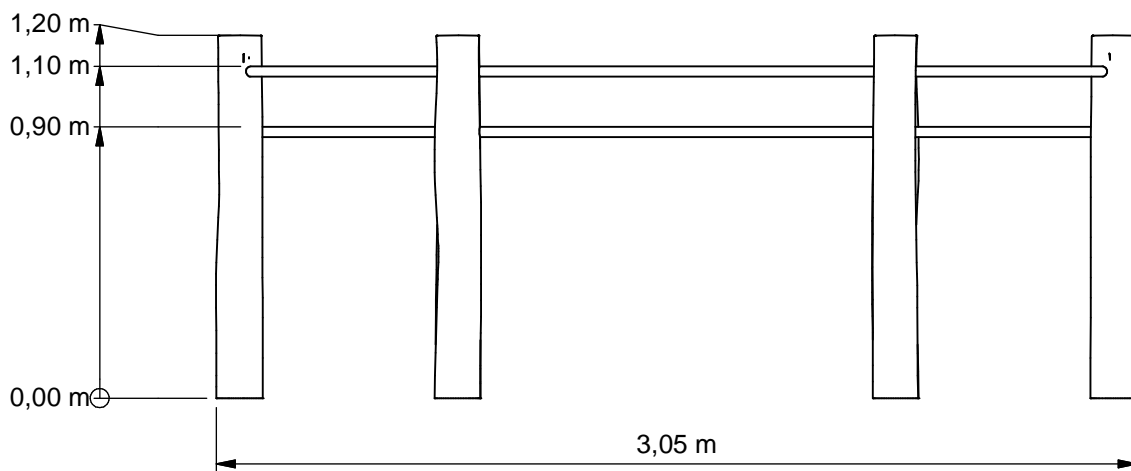
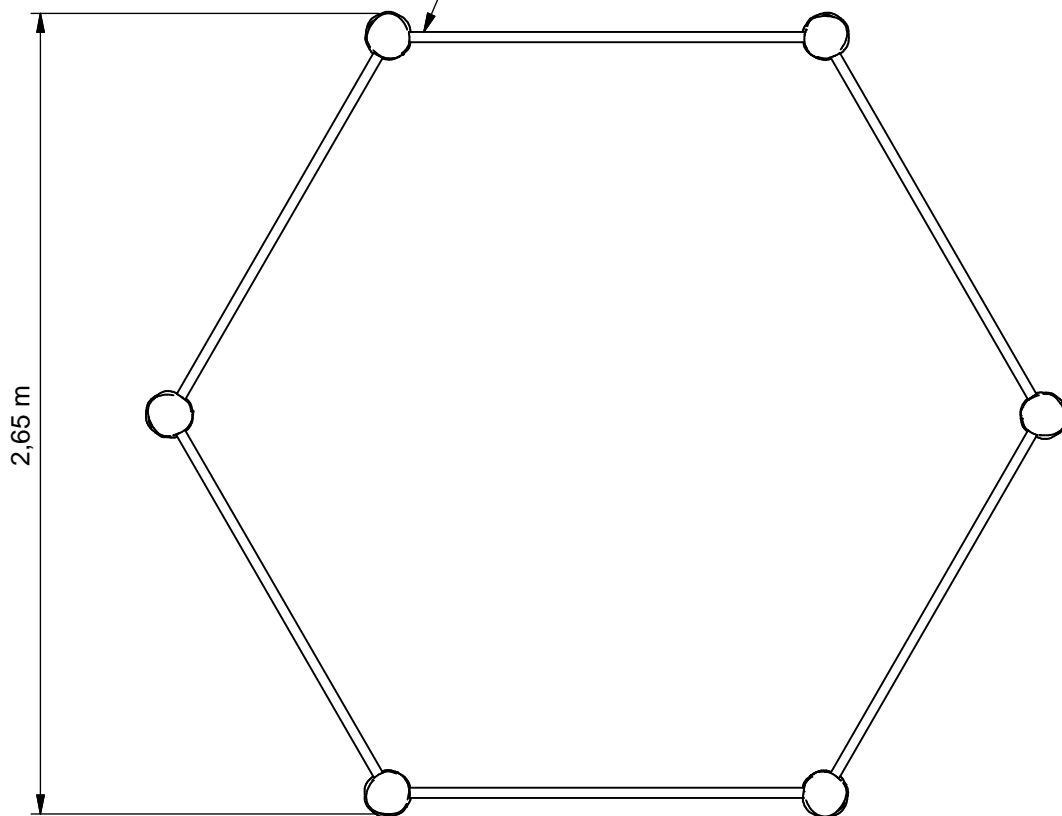

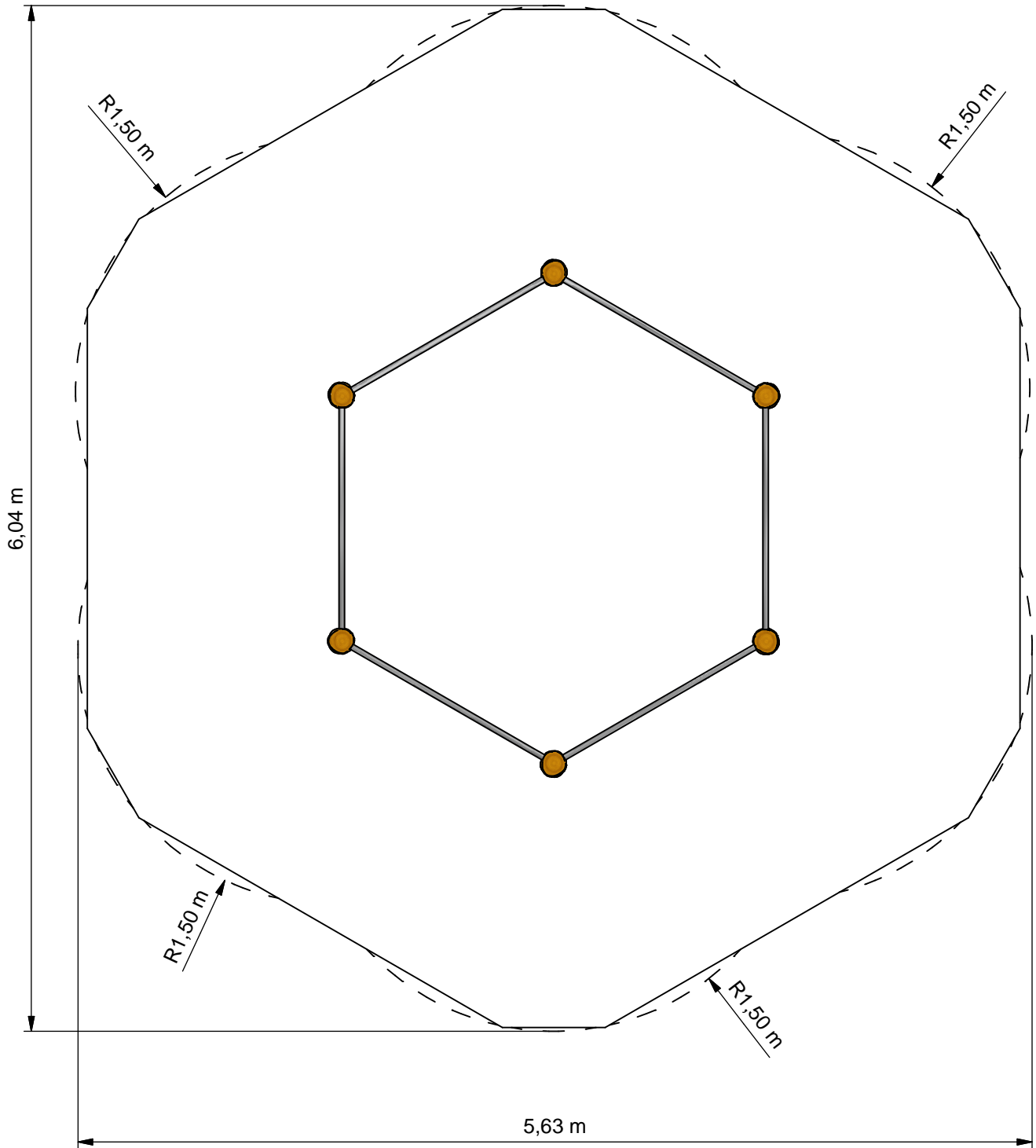

- Obstacle free EN-1176
- Obstacle free EN-1176
- Impact area
- Obstacle free WAS
- Obstacle free WAS



Benaming
Title Duikelrek

Opmerking
Comment Hexagon

Datum
Date 27-1-2017

Tekening
Drawing

TOE PST 000 084

Obstacle free zone

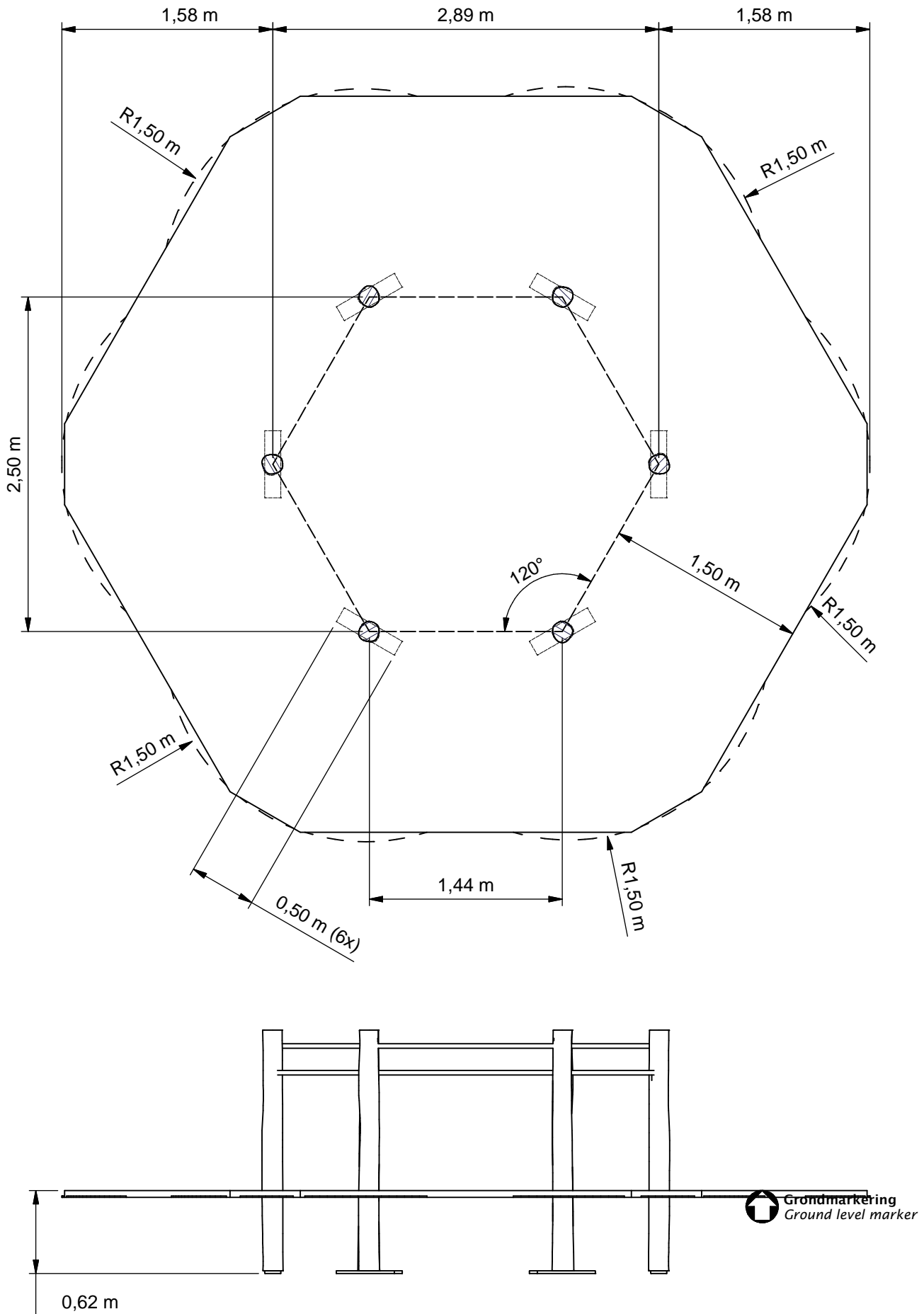

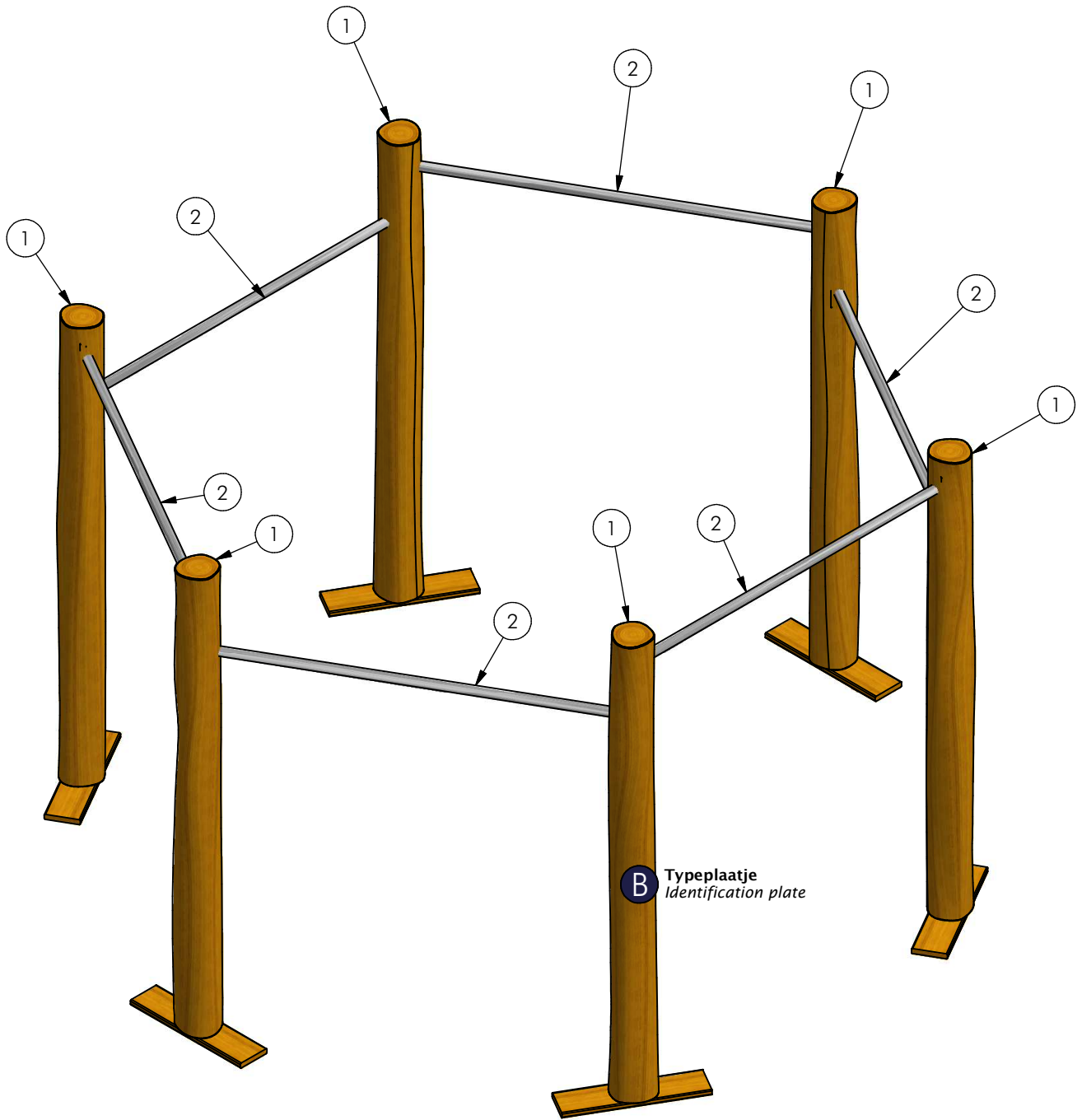

POS	N	TYPE	PROJ.	NR.	BEH.	R	BENAMING	OPMERKING
1	6	MOD	PST	007	011		Duikel	Paal H=1100
2	6	MOD	VRB	HHT	050		BUIS	DIAGONAAL



Benaming
Title Duikelrek

Opmerking
Comment Hexagon

Datum
Date 27-1-2017

Tekening
Drawing

TOE PST 000 084

Modules Modules

Geleverde modules:

Zie tabel

Supplied modules:

See table

Montageinstructie:

- De hoofdmaten geven de maten van de standers en vloeren aan
- De detailtekeningen geven specifiek de maten van de verbindingen aan
- De modules met buizen zijn op de tekeningen bemaat op bovenkant kopplaat
- Overige modules zijn bemaat op de bovenkant (klimwanden, paalkoppen, etc.)

Assembly instruction:

- The main dimensions indicate the dimensions of the posts and floors
- The detailed dimensions show the specific dimensions of the connections
- The modules which contain tubes are dimensioned at the top of the flanges
- Other modules are dimensioned at the top (climbing walls, caps for the posts, etc.)

Montagevolgorde:

- 1 - Graaf de gaten volgens het bodemplan
- 2 - Plaats 6x 1
- 3 - Verbind 6x 1 met 6x 2
- 4 - Controleer of het toestel voldoet aan de afmetingen zoals op blad 'afmetingen'
- 5 - Dicht de gaten en verdicht het zand

Assembly sequence:

- 1 - Dig the holes according to the ground plan
- 2 - Place 6x 1
- 3 - Connect 6x 1 with 6x 2
- 4 - Check that the equipment conforms to the dimensions shown on sheet 'dimensions'
- 5 - Close the holes and compact the sand

Controles:

- 1 - Correcte opbouw en alle bevestigingsmiddelen
- 2 - Controleer de afmetingen van de valbodem t.o.v. het toestel

Checks:

- 1 - Correct assembly and all the fasteners
- 2 - Check the dimensions of the safety area with regard to the play equipment

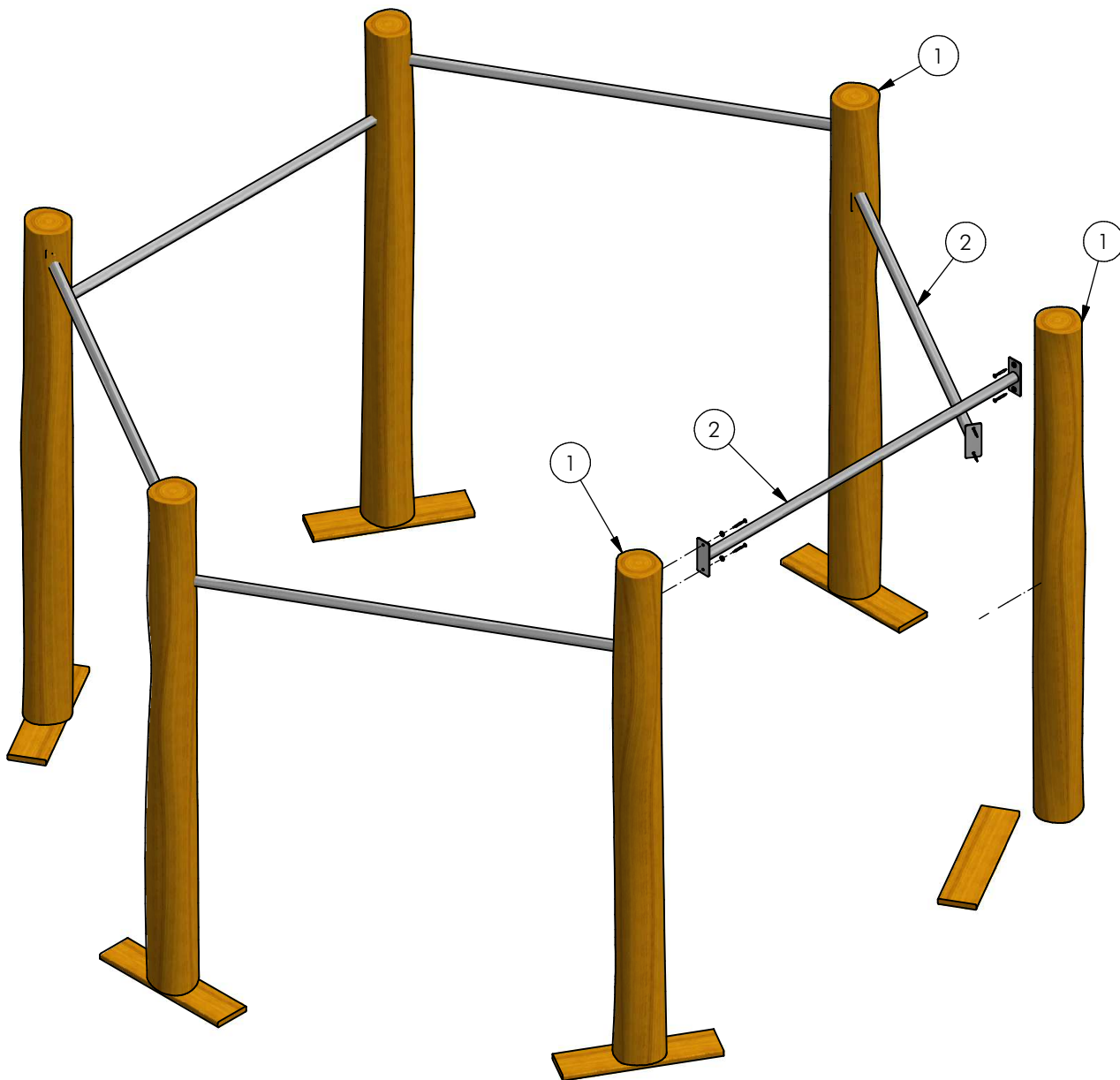

Nr	#	Type	Progr.	Volgnr	Bew.	Rev.	Benaming	Opmerking
1	6	MOD	PST	007	011		Duikel	Paal H=1100
2	6	MOD	VRB	HHT	050		BUIS	DIAGONAAL



Benaming
Title Duikelrek

Opmerking
Comment Hexagon

Datum
Date 27-1-2017

Tekening
Drawing

TOE PST 000 084

Montage Mounting

PSTE000.084

Tumble bar hexagon

LOGBOOK

(Onderstaand logboek kan gebruikt worden om te voldoen aan de eisen, gesteld in artikel 14 van het Warenwetbesluit Attractie- en Speeltoestellen)

Type indication	Adventure Play
Product code	PSTE000.084
Name of equipment	Duikel Hexagon
Maximum height of fall	1,1 m
Year of construction	2017
Certificate	031069
inspection authority	TUV Nederland QA BV De Waal 21c, Best - 5684 PH Best
Name manufacturer	BOERplay Hyacintstraat 2 - 4255 HX Nieuwendijk Phone: +31 (0)183 40 23 66 Fax: +31 (0)183 40 35 64
name installer	_____ _____
Description of equipment	Tumble bar hexagon
Location of equipment	_____
Data about the owner of the play equipment	
Name:	_____
Address:	_____
Postcode and town:	_____
Contact person:	_____
Telephone number:	_____
Data about the administrator of the play equipment	
Name:	_____
Address:	_____
Postcode and town:	_____
Contact person:	_____
Telephone number:	_____

LOGBOOK

Inspection and maintenance intervals



Nr.	Inspection	Maintenance	months between inspections
1	Verify equipment's stability, junctions and missing parts. Inspect bolts, screws and nuts for absence, jams, corrosion and wear.	Add missing parts, secure joints, apply missing fixing agent and replace corroded parts.	1
2	Check suspension for wear.	Replace worn parts and/or remove non-functioning parts.	1
3	Inspect rotating parts such as hinges, rolling-element bearings, etc. for wear and acceptability.	Replace worn parts and/or remove non-functioning parts.	1
4	Check wood for splinters, unacceptable damage and signs of rot. Especially at ground level.	Repair damage. Replace affected wood. Smoothen splintered wood and sharp edges.	1
5	Inspect foundation for stability, tearing and coverage.	Restore foundation and covering material.	3
6	Examine rubber and synthetic parts for wear, damage and break.	Replace original parts.	3
7	Inspect metal for corrosion and damage in the coating.	Restore any damaged coating (after removing rust and applying primer).	6
8	Check ropes, cables, chains and nets for wear and damage. Steel cables and nets which are tensioned must be checked for tension.	Replace parts where necessary. Steel cables and nets must be tensioned.	3
9	Inspect equipment for unsafe changes and additions.	Remove unsafe additions and correct unsafe changes.	1
10	Inspect safety surfaces.	Restore and repair where necessary.	1

Remarks

1. If used intensively, all points require extra attention.
2. Extreme weather conditions and locations may require a higher inspection frequency. Discuss this with the supplier.
3. Vandalism-sensitive locations require stricter inspections, possibly daily.
4. Check the terrain regularly for items that do not belong there, are unsafe or may be used wrongly. Examples are poisonous plants, glass shards, etc. Frequency depends on strain.
5. Remember that bad maintenance leads to unsafe conditions and notably faster impoverishment of the playground area.
6. Replacement parts can be ordered at the manufacturer with the part numbers on the module drawing. Drawings can be found in de user guide.
7. The impact area shall be provided with impact attenuating surface according to the specified falling height.
8. This list is conform the CEN-standard "playground equipment and surfacing NEN-EN 1176-7".

Warenwet

Certificaat van Typeonderzoek Type Examination Certificate

afgegeven door issued by

TÜV Nederland QA BV



aangewezen bij ministeriële beschikking van
4 mei 2012, nr. VGP 3113590

commissioned by departmental order
of 4 May 2012, no. VGP 3113590

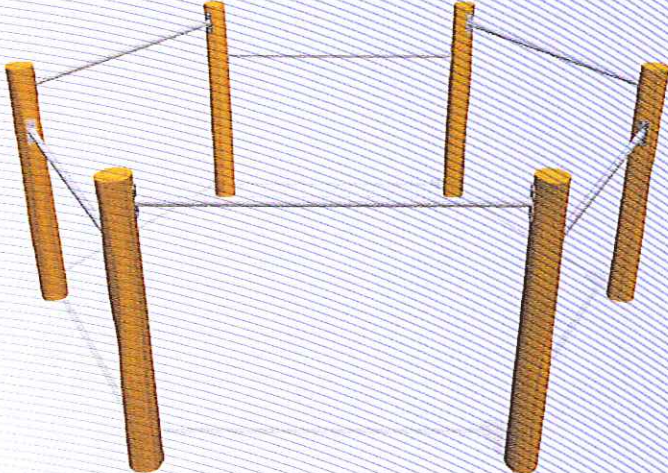
Certificaat nr. Certificate nr.	031069TA_20121005	Dossiernr. File nr.	031069TA
Productomschrijving Product description	Duikelrek Hexagon		
Evt. nadere aanduidingen Further indications	Hoogte 1,08 meter		
voor nadere informatie zie bijbehorend rapport met gelijkloidend dossiernr. for further information see associated report with identical file nr.			
Eigenaar / certificaathouder en adres Owner/certificate holder and address	Boer Speeltoestellen BV Postbus 10 4255 ZG NIEUWENDIJK		
Soort toestel Category of equipment	speeltoestel		
Fabrikant Manufacturer	Boer Speeltoestellen BV Postbus 10 4255 ZG NIEUWENDIJK		
Type/Serienummer Type/Serial number	PST.000.084 /	in te vullen door de fabrikant to be filled out by the manufacturer	
Jaar van fabricage Year of construction	vanaf 2012 since		
Leverancier Supplier	Boer Speeltoestellen BV Postbus 10 4255 ZG NIEUWENDIJK		
Jaar van leverantie Year of supply	in te vullen door de leverancier to be filled out by the supplier		
Datum keuring Date of examination	06-07-2012 – 05-10-2012		

TÜV Nederland QA BV, de Waal 21C, NL-5684 PH Best verklaart, dat het bovenaangehaalde toestel voldoet aan de vervaardigingvoorschriften genoemd in het Warenwetbesluit attractie- en speeltoestellen (met als leidraad de normatieve documenten NEN-EN 1176:2008).

TÜV Nederland QA BV declares that the here above mentioned equipment meets the safety and health requirements mentioned in the Dutch law "Warenwetbesluit attractie- en speeltoestellen" (guided by normative documents EN 1176:2008).

Namens het bestuur, For the board, A.C. Boon Directeur	
---	--

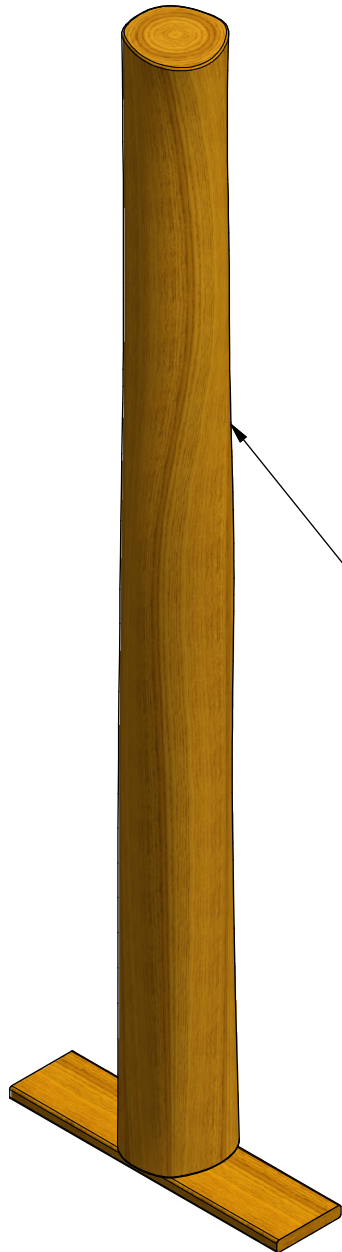

2

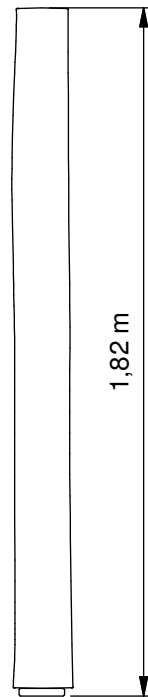

Schaal 1:20

Nr	#	Type	Progr.	Volgnr	Bew.	Rev.	Benaming	Opmerking
1	2	BSR	002	005	070		Schroef Assy	5 x 70 - RVS A2-70
2	1	OHO	PST	160	018		Paal 14-16	Lengte = 1800
3	1	OHO	PST	211	050		Standaard plank 120x20	Lengte = 500



Benaming
Title: Duikel

Opmerking
Comment: Paal H=1100

Datum
Date: 17-2-2011

Tekening
Drawing

MOD PST 007 011

Samenstelling module Assembly module

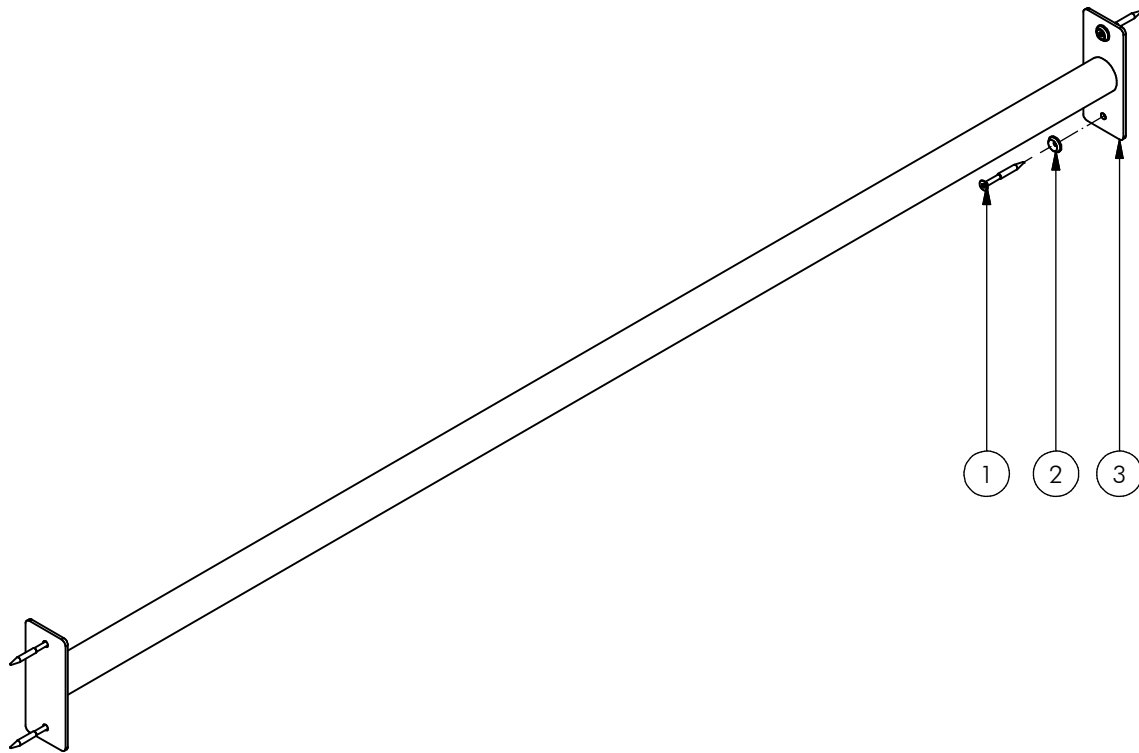

Nr	#	Type	Progr.	Volgnr	Bew.	Rev.	Benaming	Opmerking
1	4	BSR	002	005	050		Schroef Assy	5 x 50 - RVS A2-70
2	4	BSR	036	005	015		Facet ring	M5 - RVS A2-70
3	1	SME	VRB	022	320	D	SYSTEEMBUIS	DIAGONAAL



Benaming
Title BUIS

Opmerking
Comment DIAGONAAL

Datum
Date 25-9-2006

Tekening
Drawing

MOD VRB HHT 050

Samenstelling module *Assembly module*