

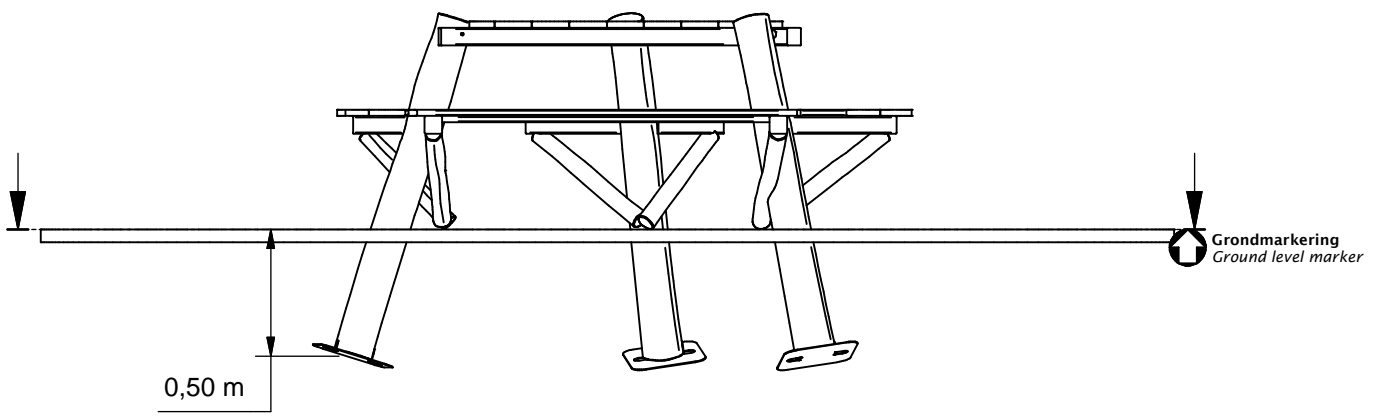

Triangle Picnic

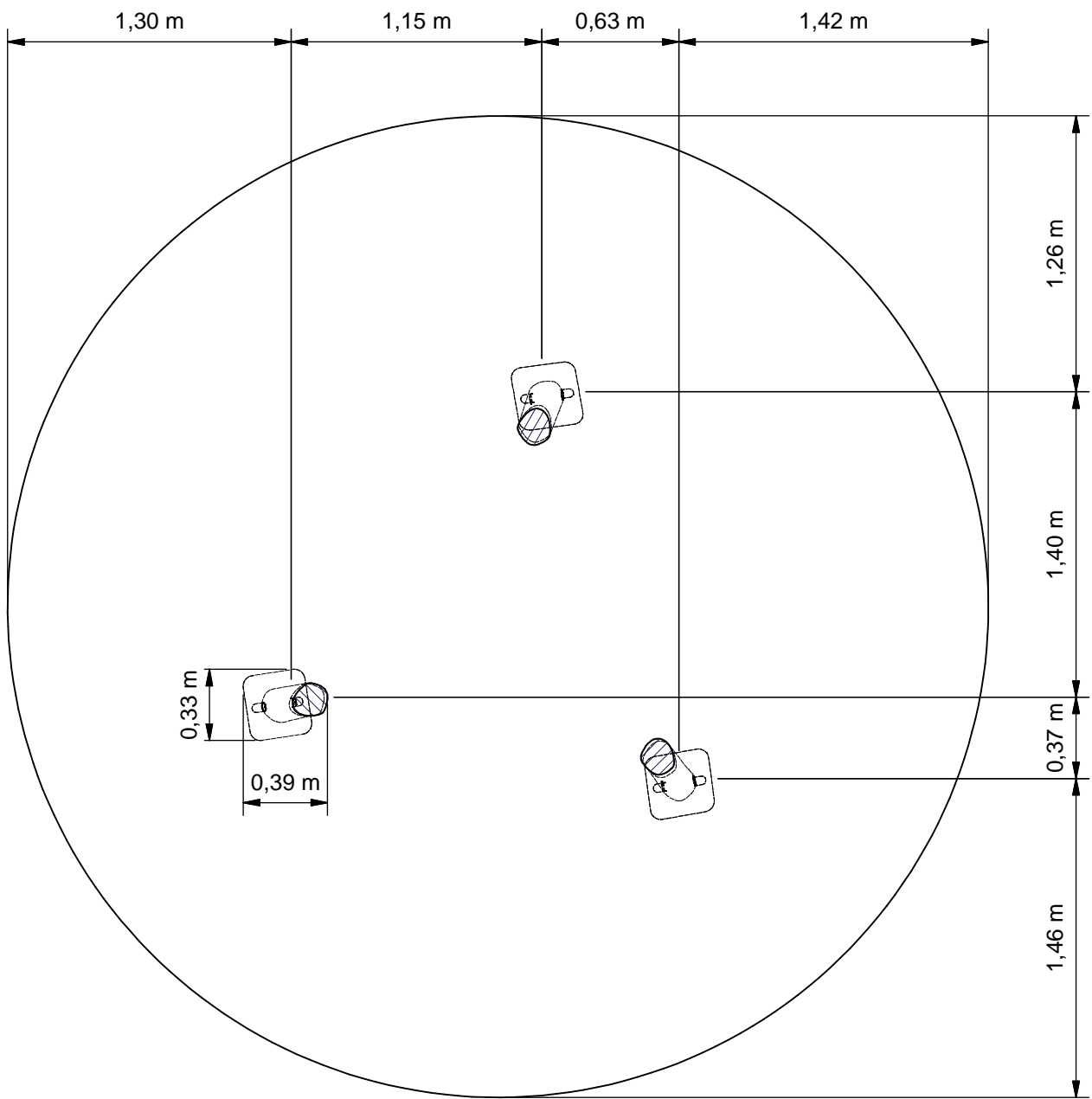

PSTE000.209



Benaming
 Title Picknickset
 Opmerking
 Comment Adventure Play
 Datum
 Date 20-7-2011

Tekening
Drawing

TOE PST 000 209

Bodemplan Groundplan

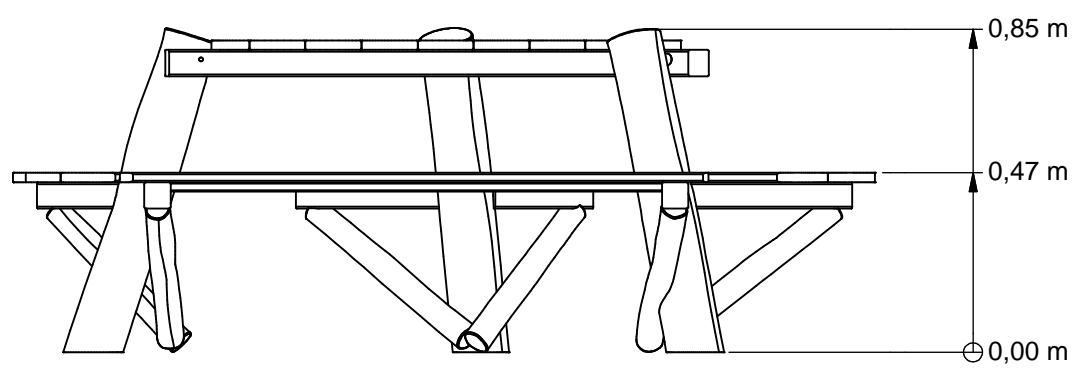
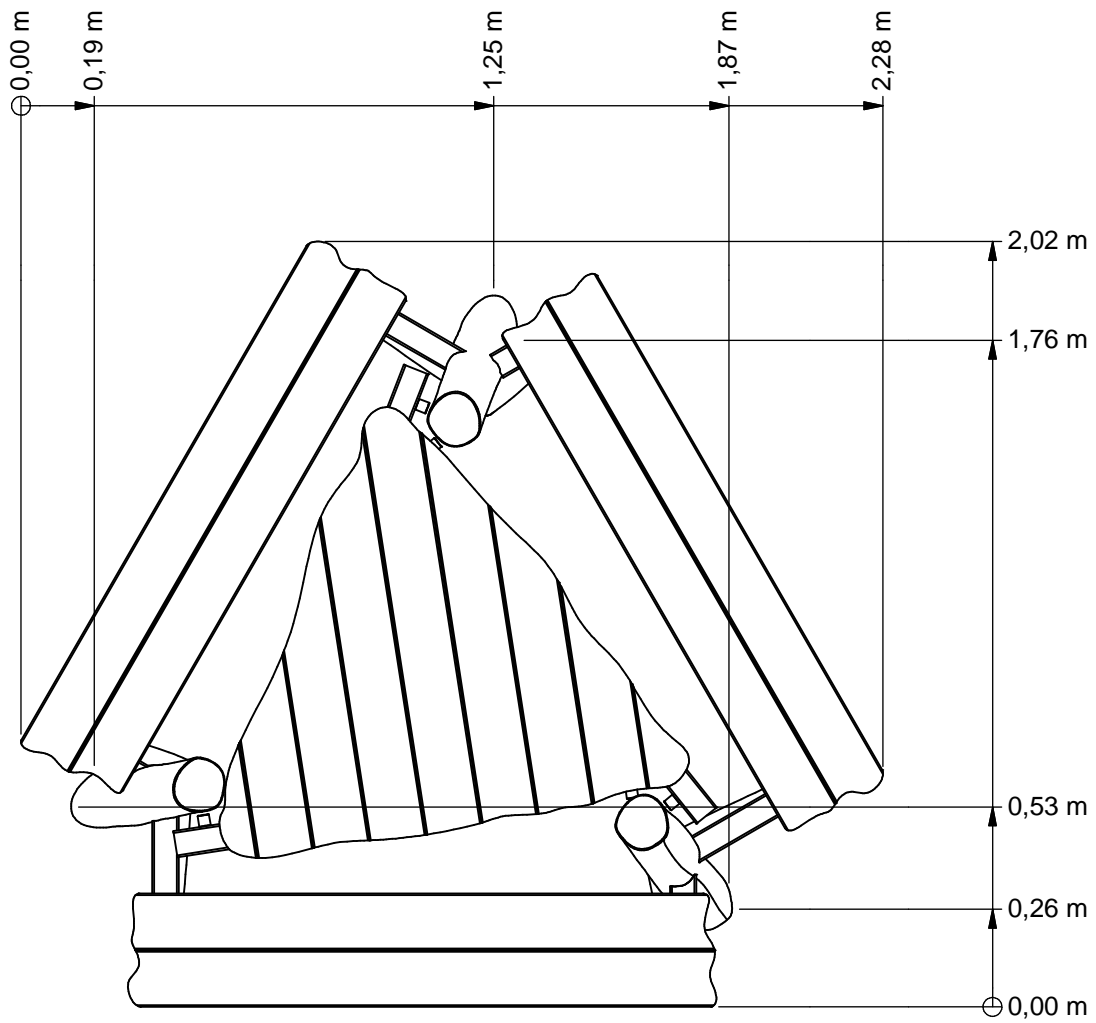

Benaming
Title Picknickset

Opmerking
Comment Adventure Play

Datum
Date 20-7-2011

Tekening
Drawing

TOE PST 000 209

Afmetingen Dimensions

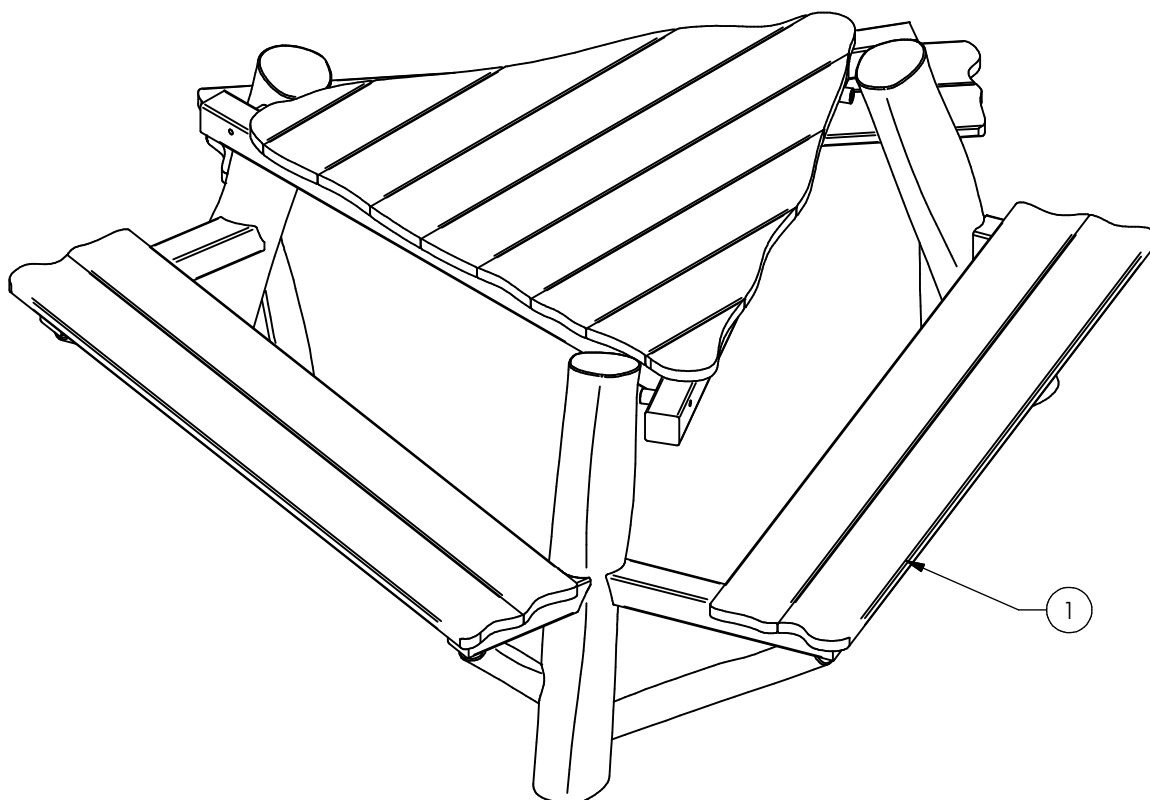

Geadviseerde Bouwvolgorde:

Bepaal, voor het plaatsen, de positie van het toestel, houdt daarbij rekening met voldoende ruimte voor gebruik van de picknickset en de afmetingen van de grondankers.

Gewicht & Afmetingen

Gewicht: < 175 kg
 Grote: 1,35 x 2,2 x 2,2 mtr

Daarna gaten graven, zoals aangegeven op het bodemplan.

Nr	#	Type	Progr.	Volgnr	Bew.	Rev.	Benaming	Opmerking
1	1	MOD	PST	046	002		Tafel Driehoek vz	Adventure Play



Benaming
 Title Picknickset
 Opmerking
 Comment Adventure Play
 Datum
 Date 20-7-2011

Tekening
 Drawing

TOE PST 000 209

Montage Mounting

PSTE000.209

Triangle Picnic

LOGBOOK

(Onderstaand logboek kan gebruikt worden om te voldoen aan de eisen, gesteld in artikel 14 van het Warenwetbesluit Attractie- en Speeltoestellen)

Type indication	Streetfurniture
Product code	PSTE000.209
Name of equipment	Driehoek Picknickset
Maximum height of fall	n.a.
Year of construction	2017
Certificate	0183402366
inspection authority	NVT -
Name manufacturer	BOERplay Hyacintstraat 2 - 4255 HX Nieuwendijk Phone: +31 (0)183 40 23 66 Fax: +31 (0)183 40 35 64
name installer	_____ _____
Description of equipment	Triangle Picnic
Location of equipment	_____
Data about the owner of the play equipment	
Name:	_____
Address:	_____
Postcode and town:	_____
Contact person:	_____
Telephone number:	_____
Data about the administrator of the play equipment	
Name:	_____
Address:	_____
Postcode and town:	_____
Contact person:	_____
Telephone number:	_____

LOGBOOK

Inspection and maintenance intervals



Nr.	Inspection	Maintenance	months between inspections
1	Verify equipment's stability, junctions and missing parts. Inspect bolts, screws and nuts for absence, jams, corrosion and wear.	Add missing parts, secure joints, apply missing fixing agent and replace corroded parts.	1
2	Check suspension for wear.	Replace worn parts and/or remove non-functioning parts.	1
3	Inspect rotating parts such as hinges, rolling-element bearings, etc. for wear and acceptability.	Replace worn parts and/or remove non-functioning parts.	1
4	Check wood for splinters, unacceptable damage and signs of rot. Especially at ground level.	Repair damage. Replace affected wood. Smoothen splintered wood and sharp edges.	1
5	Inspect foundation for stability, tearing and coverage.	Restore foundation and covering material.	3
6	Examine rubber and synthetic parts for wear, damage and break.	Replace original parts.	3
7	Inspect metal for corrosion and damage in the coating.	Restore any damaged coating (after removing rust and applying primer).	6
8	Check ropes, cables, chains and nets for wear and damage. Steel cables and nets which are tensioned must be checked for tension.	Replace parts where necessary. Steel cables and nets must be tensioned.	3
9	Inspect equipment for unsafe changes and additions.	Remove unsafe additions and correct unsafe changes.	1
10	Inspect safety surfaces.	Restore and repair where necessary.	1

Remarks

1. If used intensively, all points require extra attention.
2. Extreme weather conditions and locations may require a higher inspection frequency. Discuss this with the supplier.
3. Vandalism-sensitive locations require stricter inspections, possibly daily.
4. Check the terrain regularly for items that do not belong there, are unsafe or may be used wrongly. Examples are poisonous plants, glass shards, etc. Frequency depends on strain.
5. Remember that bad maintenance leads to unsafe conditions and notably faster impoverishment of the playground area.
6. Replacement parts can be ordered at the manufacturer with the part numbers on the module drawing. Drawings can be found in de user guide.
7. The impact area shall be provided with impact attenuating surface according to the specified falling height.
8. This list is conform the CEN-standard "playground equipment and surfacing NEN-EN 1176-7".



Dit toestel is geen speeltoestel conform het warenwetbesluit attractie- en speeltoestellen, en is dus niet als zodanig gecertificeerd.

This equipment is not playground equipment, so it has not been certified as such.



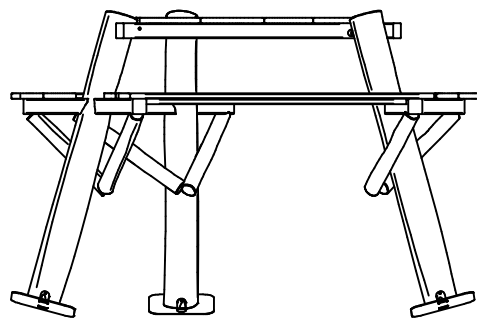
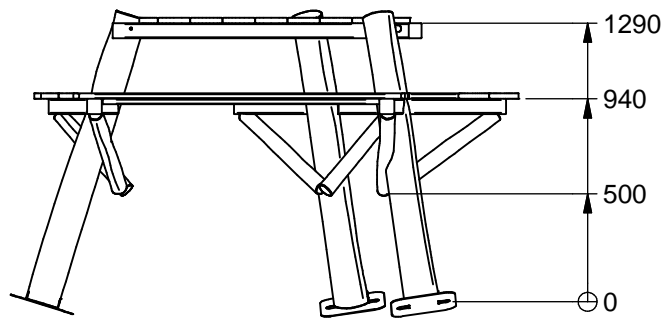
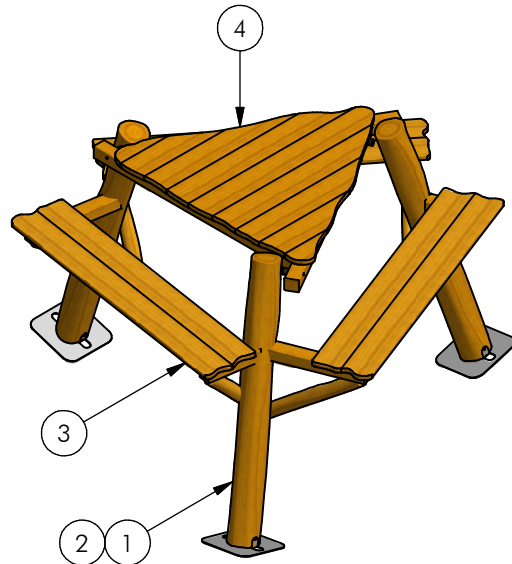
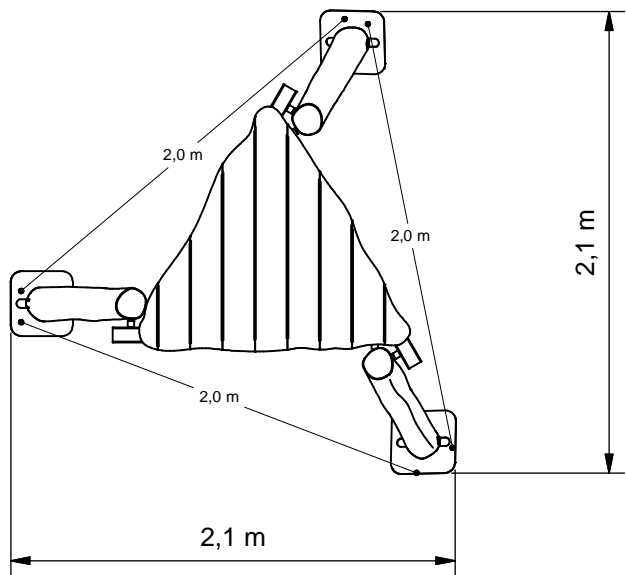

4	1	SMD	PST	003	002	Vloertje 1m	Adventure Play	
3	3	SHO	PST	082	001	Zitvlak	Adventure Play	
2	3	OME	JGP	001	VZP	Voetplaat	Jungleplay	
1	3	OHO	PST	160	014	Paal 14-16	Lengte =1400	
POS	N	TYPE	PROJ	NR.	BEH.	R	BENAMING	OPMERKING

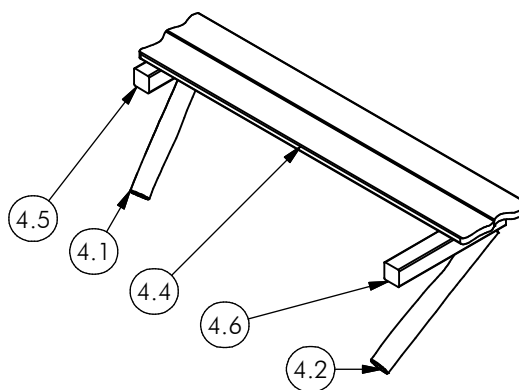
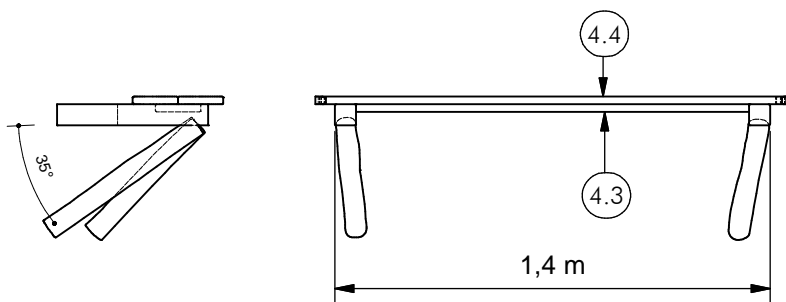

4.6	1	OHO	PST	307	050	70 mm Vierkante paal	500 mm Lengte	
4.5	1	OHO	PST	307	030	70 mm Vierkante paal	300 mm Lengte	
4.4	2	OHO	PST	222	160	Lat 150x25	Lengte = 1600	
4.3	1	OHO	PST	222	130	Lat 150x25	Lengte = 1300	
4.2	1	OHO	PST	080	006	Paal 6-8	Lengte =600	
4.1	1	OHO	PST	080	005	Paal 6-8	Lengte =500	
POS	N	TYPE	PROJ	NR.	BEH.	R	BENAMING	OPMERKING



Benaming
Title Zitvlak

Opmerking
Comment Adventure Play

Datum
Date 5-4-2012

Tekening
Drawing

MOD PST 046 002

Samenstelling module Assembly module