

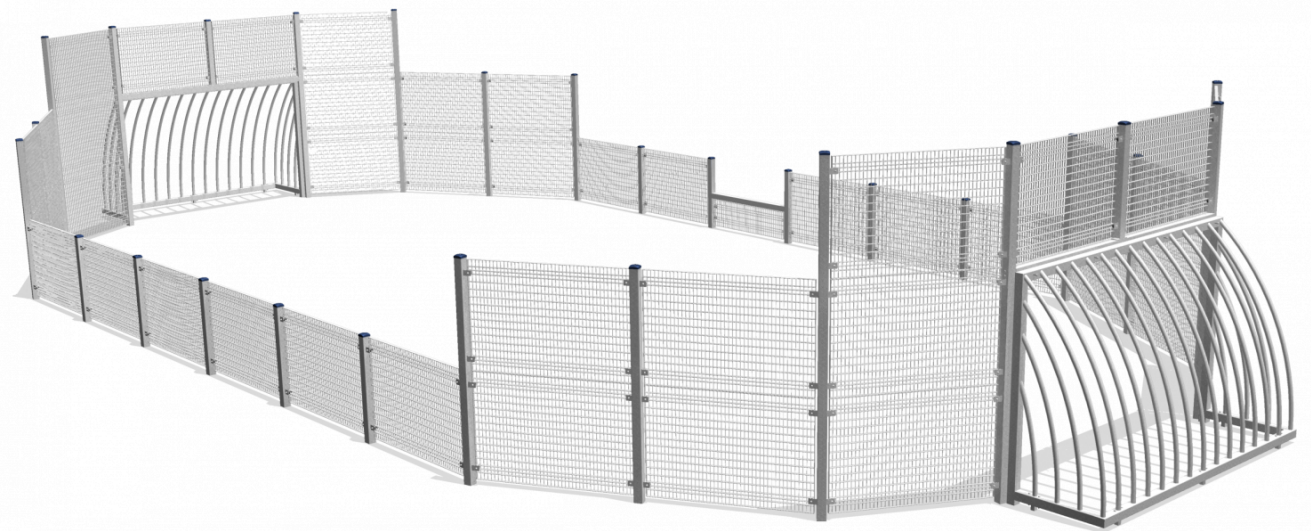

# Soccer court

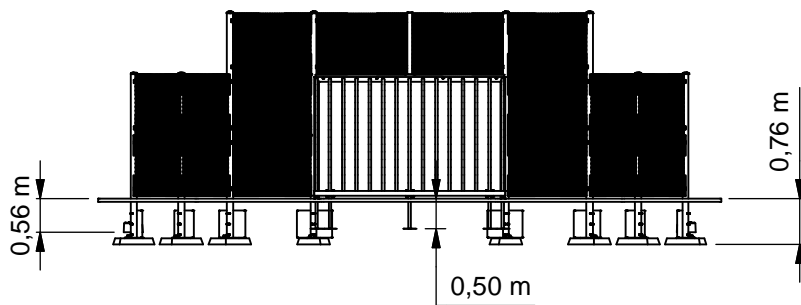

SPT E230.049

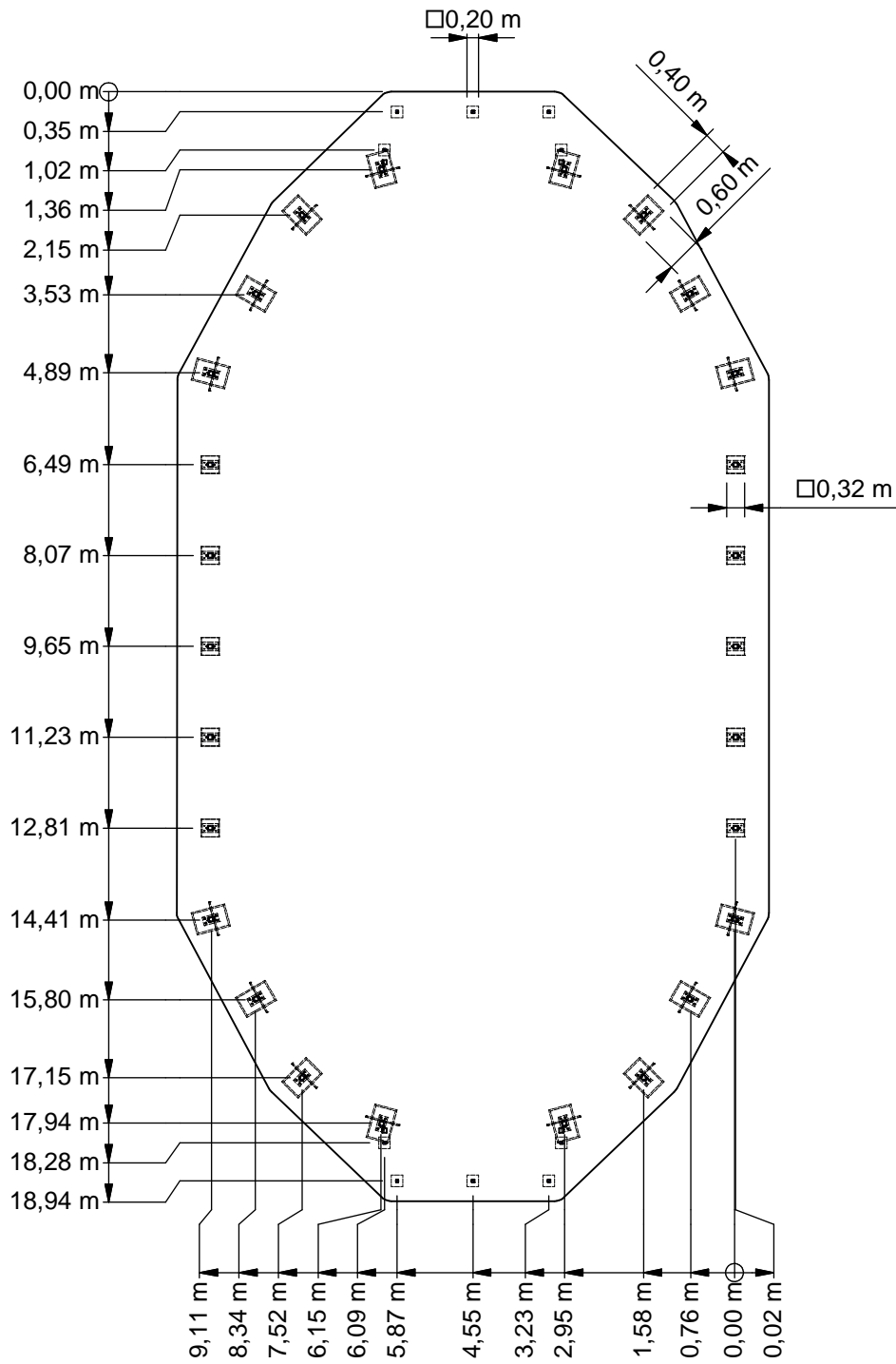

Benaming  
Title Sportveld 230

Opmerking  
Comment 9,1 x 16,5 x 3,1m

Datum  
Date 26-6-2012

Tekening  
Drawing

TOE SPT 230 049

Bodemplan Groundplan

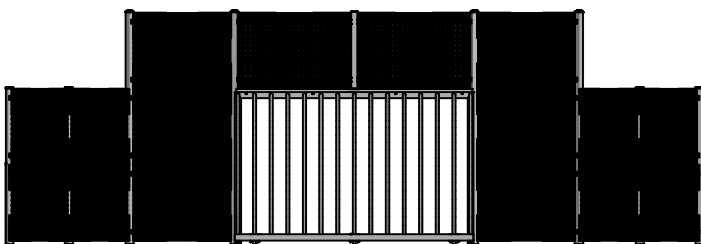
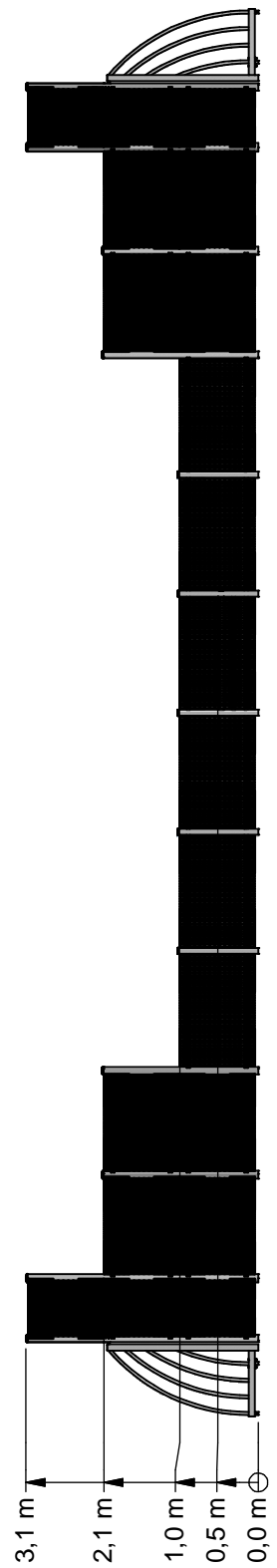
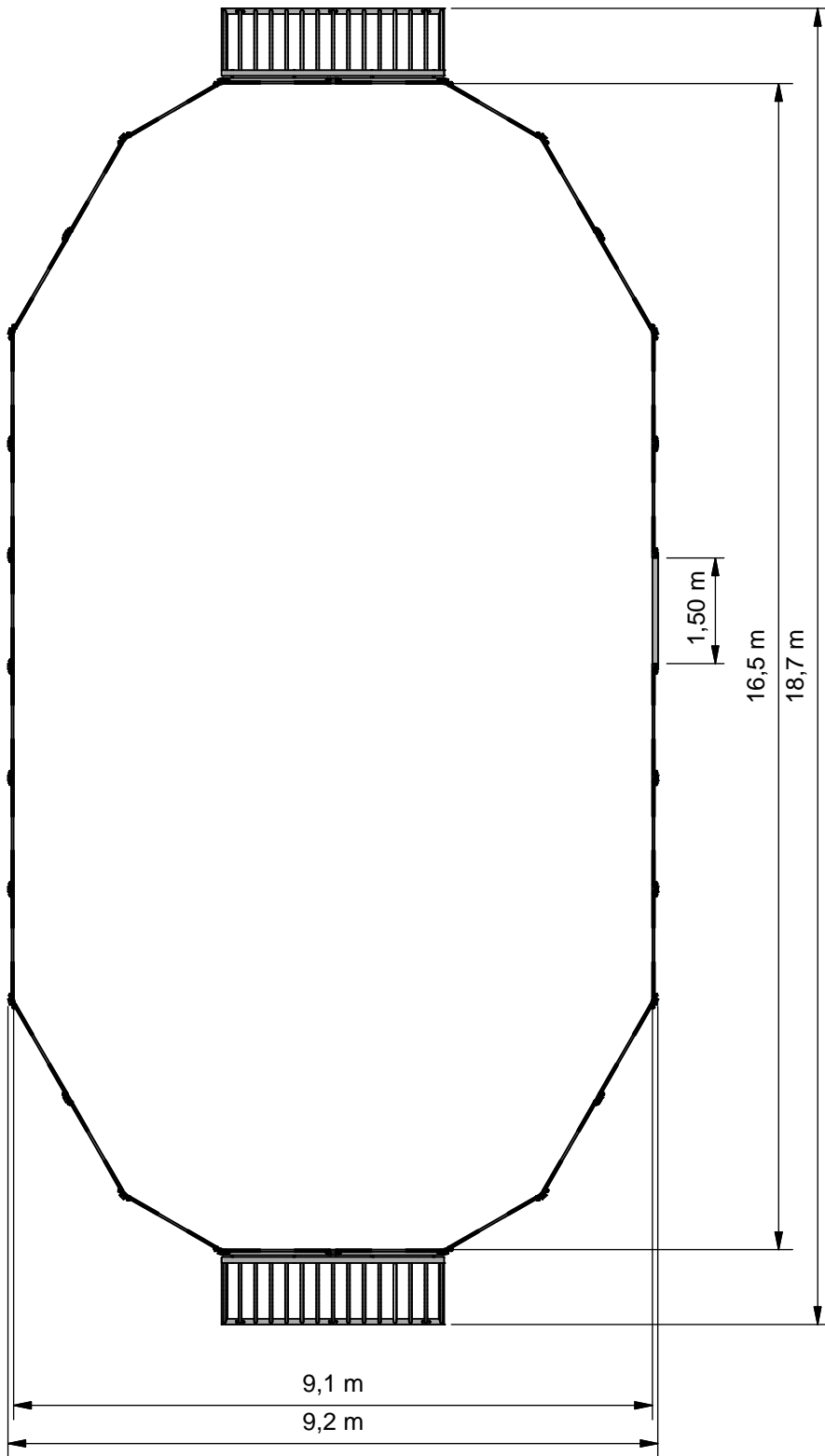

Benaming  
Title Sportveld 230  
Opmerking  
Comment 9,1 x 16,5 x 3,1m  
Datum  
Date 26-6-2012

Tekening  
Drawing

TOE SPT 230 049

Afmetingen Dimensions

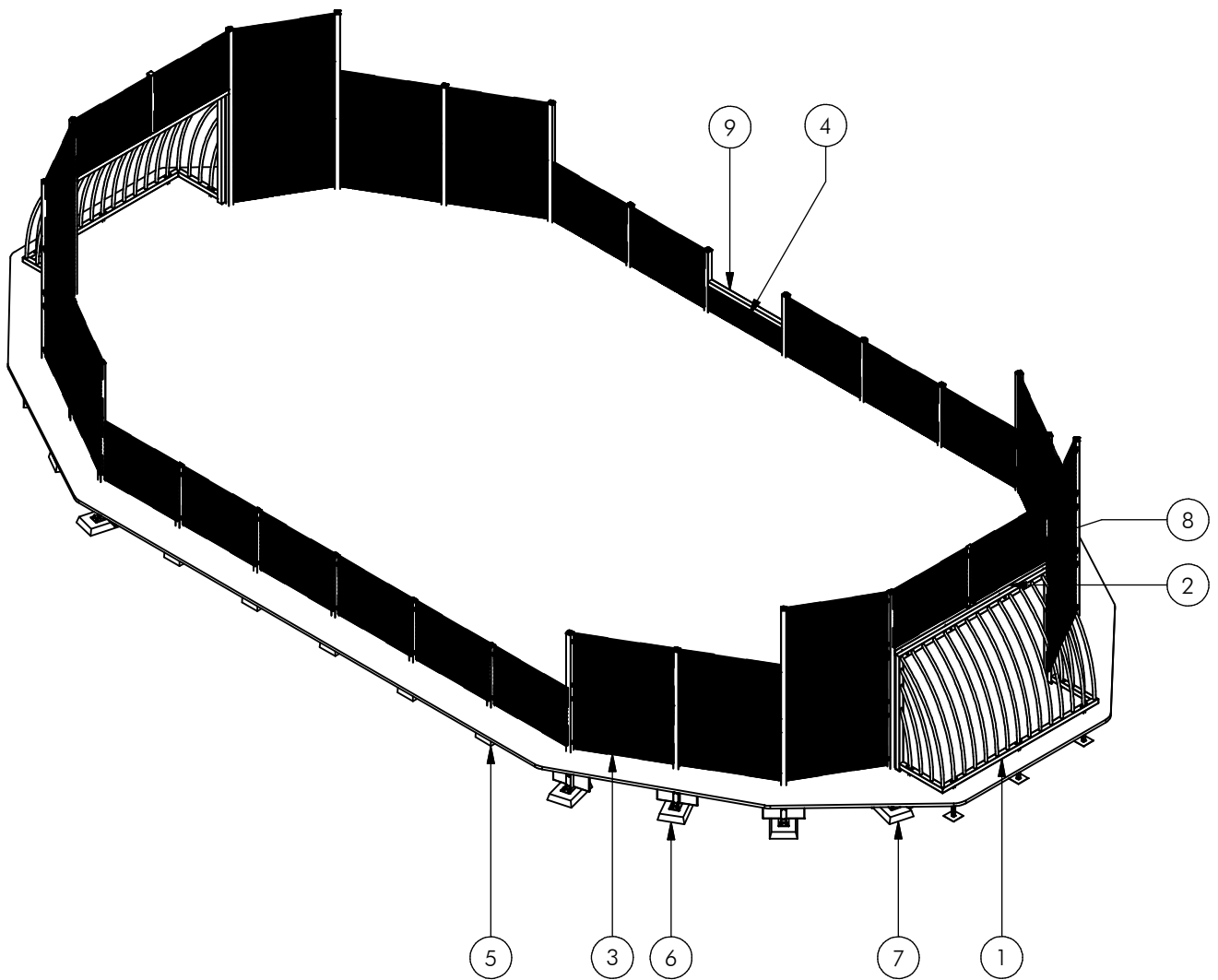

POS	N	TYPE	PROJ.	NR.	BEH.	R	BENAMING	OPMERKING
1	2	MOD	SPT	006	011		Maxigoal met grondankers	SPT
2	2	MOD	SPT	007	014		Bovenbalk 3,0m Schuin	met Gaten, SPT
3	43	MOD	SPT	035	001		Persrooster 1,5 x 1,0 m	Pannaveld
4	1	MOD	SPT	035	003		Persrooster 1,5 x 0,5 m	Pannaveld
5	10	MOD	SPT	037	010	A	SPT - Staander met Poer	H 1,0 m
6	8	MOD	SPT	037	020	A	SPT - Staander met Poer	H 2,0 m
7	8	MOD	SPT	037	030	A	SPT - Staander met Poer	H 3,0 m
8	2	MOD	SPT	037	230		Paal op Maxi Goal	tbv H 3,0 m
9	1	MOD	SPT	007	028		Bovenbalk 1,5m	SPT



Benaming  
Title Sportveld 230

Opmerking  
Comment 9,1 x 16,5 x 3,1m

Datum  
Date 26-6-2012

Tekening  
Drawing

TOE SPT 230 049

Modules Modules

# SPTE230.049

Soccer court

## LOGBOOK

(Onderstaand logboek kan gebruikt worden om te voldoen aan de eisen, gesteld in artikel 14 van het Warenwetbesluit Attractie- en Speeltoestellen)

Type indication	Sports equipment
Product code	SPTE230.049
Name of equipment	SPT sportveld 16,7 x 9,3 m
Maximum height of fall	n.a.
Year of construction	2017
Certificate	0183402366
inspection authority	NVT -
Name manufacturer	BOERplay Hyacintstraat 2 - 4255 HX Nieuwendijk Phone: +31 (0)183 40 23 66 Fax: +31 (0)183 40 35 64
name installer	_____ _____
Description of equipment	Soccer court
Location of equipment	_____
Data about the owner of the play equipment	
Name:	_____
Address:	_____
Postcode and town:	_____
Contact person:	_____
Telephone number:	_____
Data about the administrator of the play equipment	
Name:	_____
Address:	_____
Postcode and town:	_____
Contact person:	_____
Telephone number:	_____

# LOGBOOK

## Inspection and maintenance intervals



Nr.	Inspection	Maintenance	months between inspections
1	Verify equipment's stability, junctions and missing parts. Inspect bolts, screws and nuts for absence, jams, corrosion and wear.	Add missing parts, secure joints, apply missing fixing agent and replace corroded parts.	1
2	Check suspension for wear.	Replace worn parts and/or remove non-functioning parts.	1
3	Inspect rotating parts such as hinges, rolling-element bearings, etc. for wear and acceptability.	Replace worn parts and/or remove non-functioning parts.	1
4	Check wood for splinters, unacceptable damage and signs of rot. Especially at ground level.	Repair damage. Replace affected wood. Smoothen splintered wood and sharp edges.	1
5	Inspect foundation for stability, tearing and coverage.	Restore foundation and covering material.	3
6	Examine rubber and synthetic parts for wear, damage and break.	Replace original parts.	3
7	Inspect metal for corrosion and damage in the coating.	Restore any damaged coating (after removing rust and applying primer).	6
8	Check ropes, cables, chains and nets for wear and damage. Steel cables and nets which are tensioned must be checked for tension.	Replace parts where necessary. Steel cables and nets must be tensioned.	3
9	Inspect equipment for unsafe changes and additions.	Remove unsafe additions and correct unsafe changes.	1
10	Inspect safety surfaces.	Restore and repair where necessary.	1

## Remarks

1. If used intensively, all points require extra attention.
2. Extreme weather conditions and locations may require a higher inspection frequency. Discuss this with the supplier.
3. Vandalism-sensitive locations require stricter inspections, possibly daily.
4. Check the terrain regularly for items that do not belong there, are unsafe or may be used wrongly. Examples are poisonous plants, glass shards, etc. Frequency depends on strain.
5. Remember that bad maintenance leads to unsafe conditions and notably faster impoverishment of the playground area.
6. Replacement parts can be ordered at the manufacturer with the part numbers on the module drawing. Drawings can be found in de user guide.
7. The impact area shall be provided with impact attenuating surface according to the specified falling height.
8. This list is conform the CEN-standard "playground equipment and surfacing NEN-EN 1176-7".



Dit toestel is geen speeltoestel conform het warenwetbesluit attractie- en speeltoestellen, en is dus niet als zodanig gecertificeerd.

*This equipment is not playground equipment, so it has not been certified as such.*



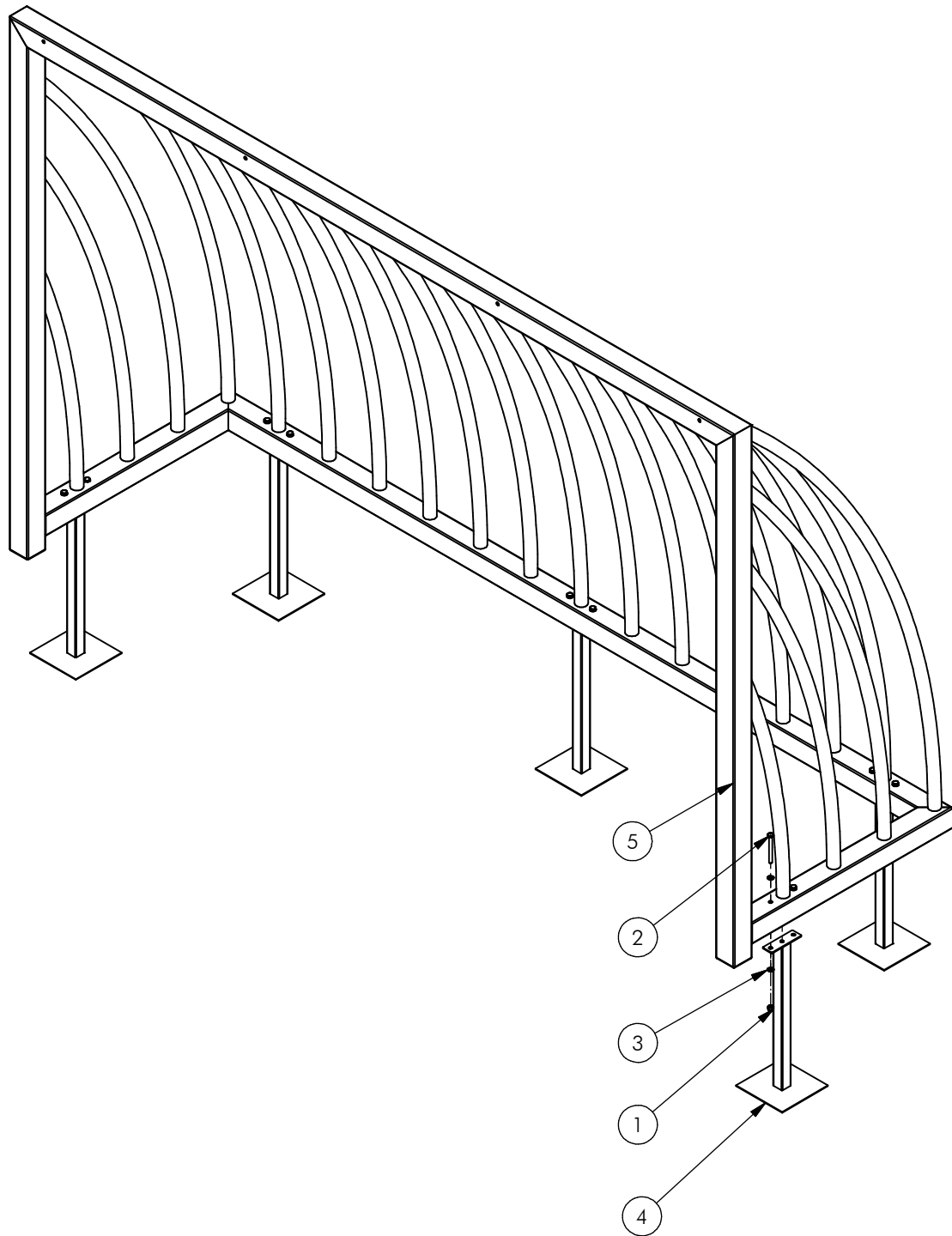

Nr	#	Type	Progr.	Volgnr	Bew.	Rev.	Benaming	Opmerking
1	10	BSV	011	010	020		Borgdopmoer	M10 - VZ 8.8
2	10	BSV	021	010	100		Zeskantbout ISO 4014	M10 x 100 - VZ 8.8
3	20	BSV	030	010	002		Sluitring	M10 - VZ 8.8
4	5	SME	SOL	032	372	C	Grondanker	Goal
5	1	SME	SPT	002	372	A	MAXI GOAL	SPT



Benaming  
Title Maxigoal met grondankers

Opmerking  
Comment SPT

Datum  
Date 28-11-2011

Tekening  
Drawing

**MOD SPT 006 011**

Samenstelling module Assembly module



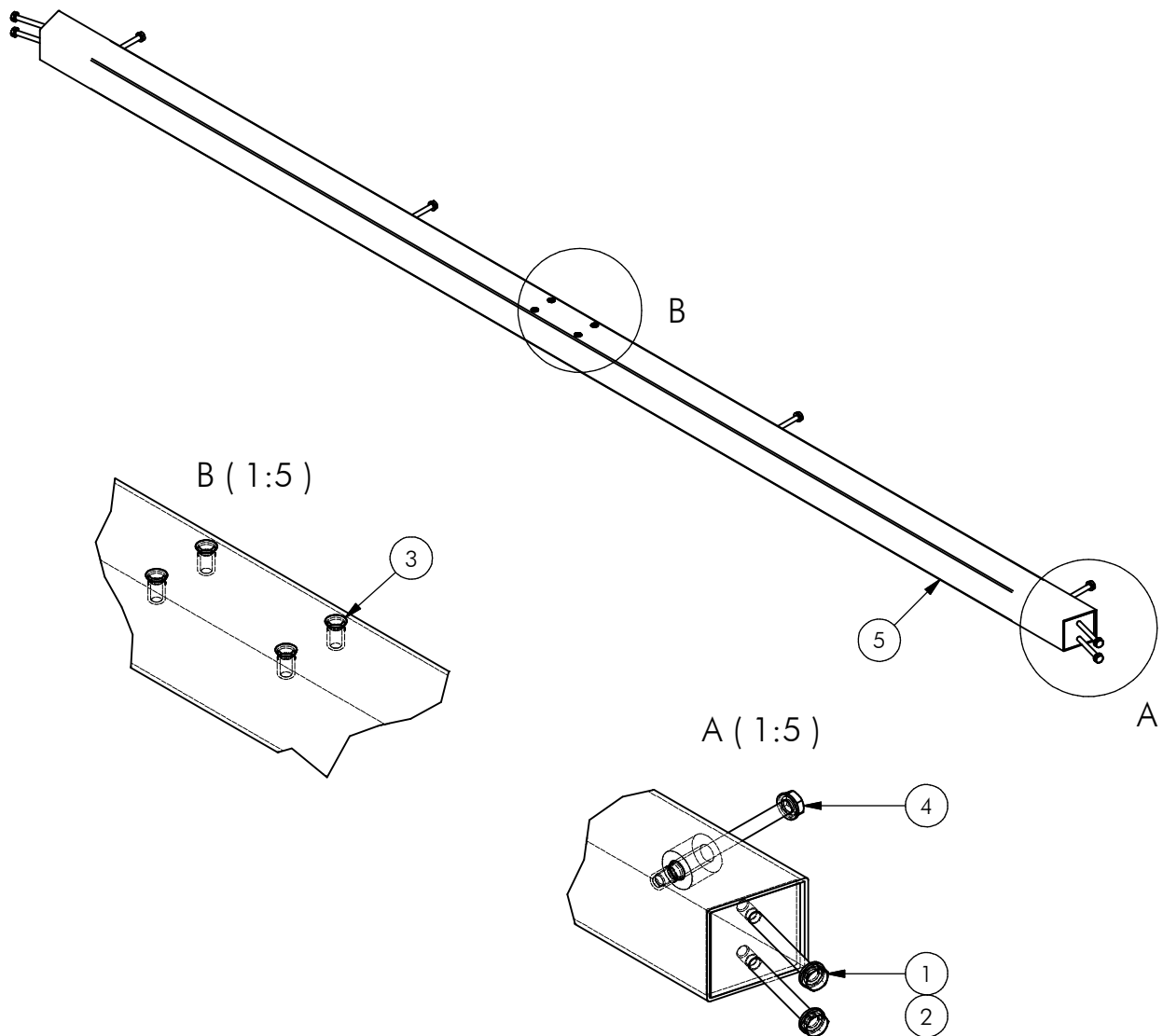

Nr	#	Type	Progr.	Volgnr	Bew.	Rev.	Benaming	Opmerking
1	4	BSV	021	010	100		Zeskantbout ISO 4014	M10 x 100 - VZ 8.8
2	4	BSV	032	010	002		Veerring	M10 - VZ 8.8
3	8	BSV	044	010	021		Blindklinkmoer	M10 - VZ 8.8
4	4	SMD	SPT	000	003		Afstandsbus L	SPT-Goals
5	1	SME	SPT	046	372	A	Bovenbalk 3,0 mtr Schuin	SPT



Benaming  
Title Bovenbalk 3,0m Schuin

Opmerking  
Comment met Gat, SPT

Datum  
Date 17-11-2011

Tekening  
Drawing

MOD SPT 007 014

Samenstelling module Assembly module

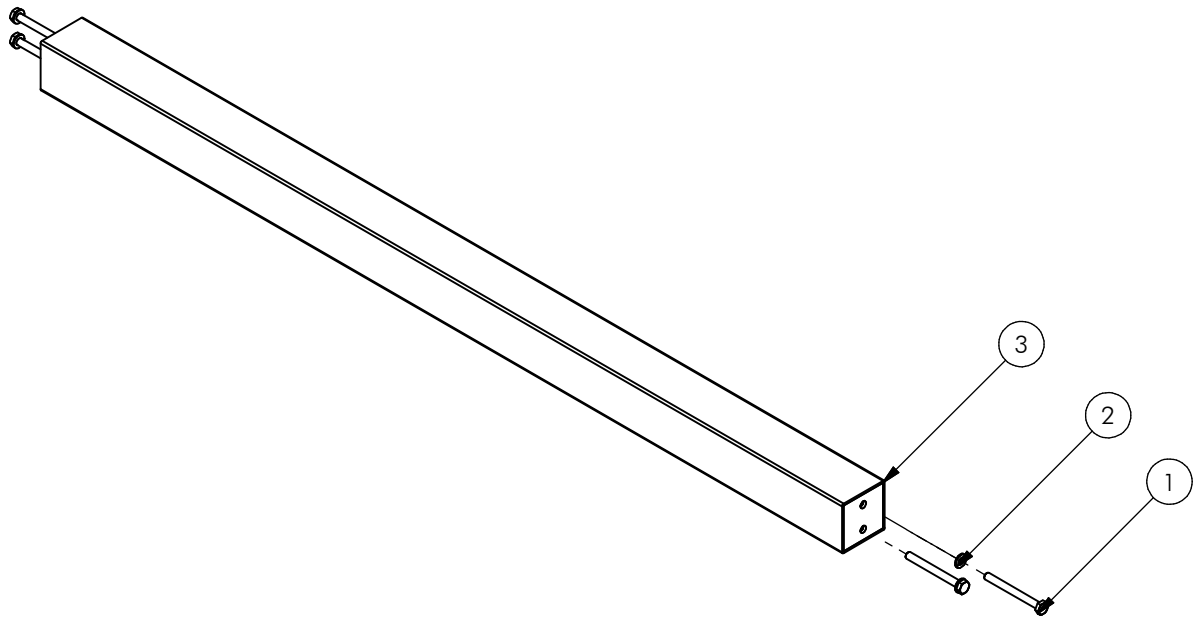

Nr	#	Type	Progr.	Volgnr	Bew.	Rev.	Benaming	Opmerking
1	4	BSV	021	010	100		Zeskantbout ISO 4014	M10 x 100 - VZ 8.8
2	4	BSV	034	010	002		Veerring	M10 - VZ 8.8
3	1	SME	SPT	109	372		Bovenbalk zonder gaten	SPT



Benaming  
Title | Bovenbalk 1,5m

Opmerking  
Comment | SPT

Datum  
Date | 13-3-2017

Tekening  
Drawing

**MOD SPT 007 028**

**Samenstelling module Assembly module**

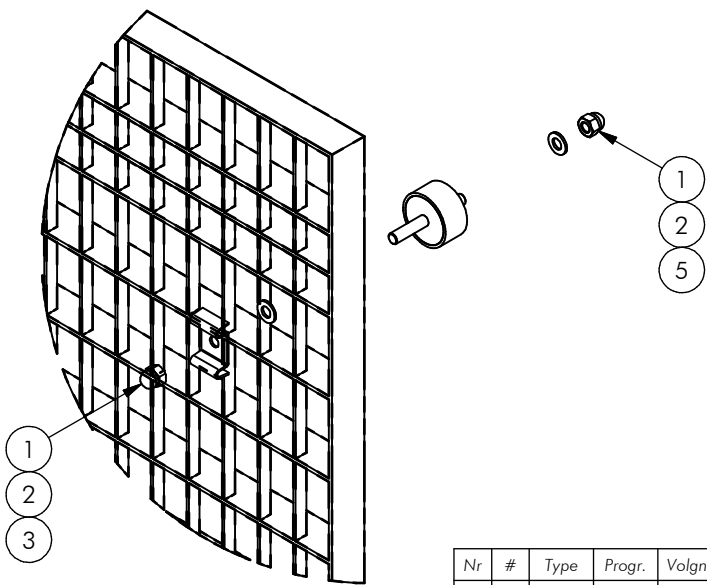
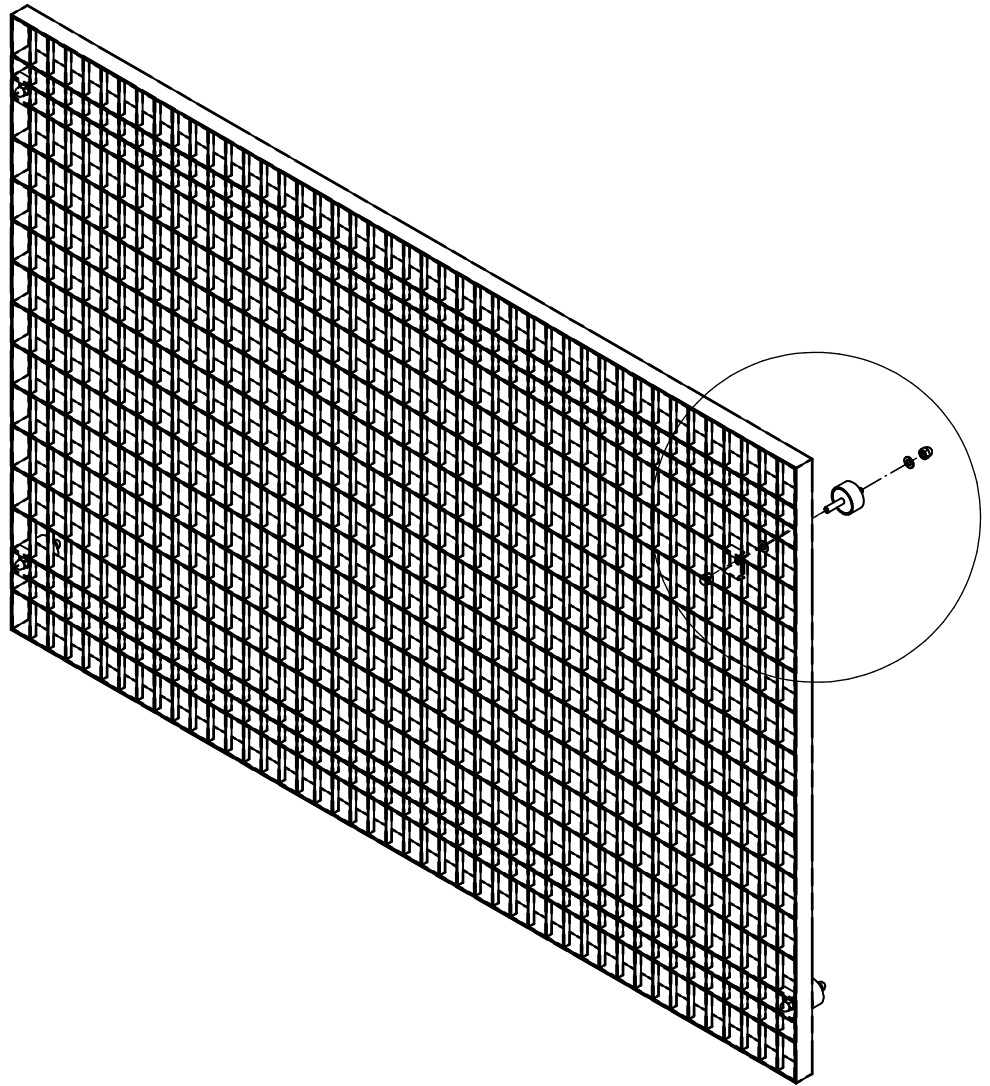

Nr	#	Type	Progr.	Volgnr	Bew.	Rev.	Benaming	Opmerking
1	8	BSV	011	008	015		Borgdopmoer	M8 - VZ 8.8
2	8	BSV	030	008	016		Sluitring	M8 - VZ 8.8
3	4	OME	SPT	114	001		Zadel	SPT
4	1	OME	SPT	140	372		persrooster 30,3/3	tbv stramien 1½ x 1
5	4	TNB	MDR	006			Demper 40x20	M8x30/15



Benaming / Title: Persrooster 1,5 x 1,0 m  
 Opmerking / Comment: Pannaveld  
 Datum / Date: 30-10-2012

Tekening / Drawing

**MOD SPT 035 001**

Samenstelling module *Assembly module*

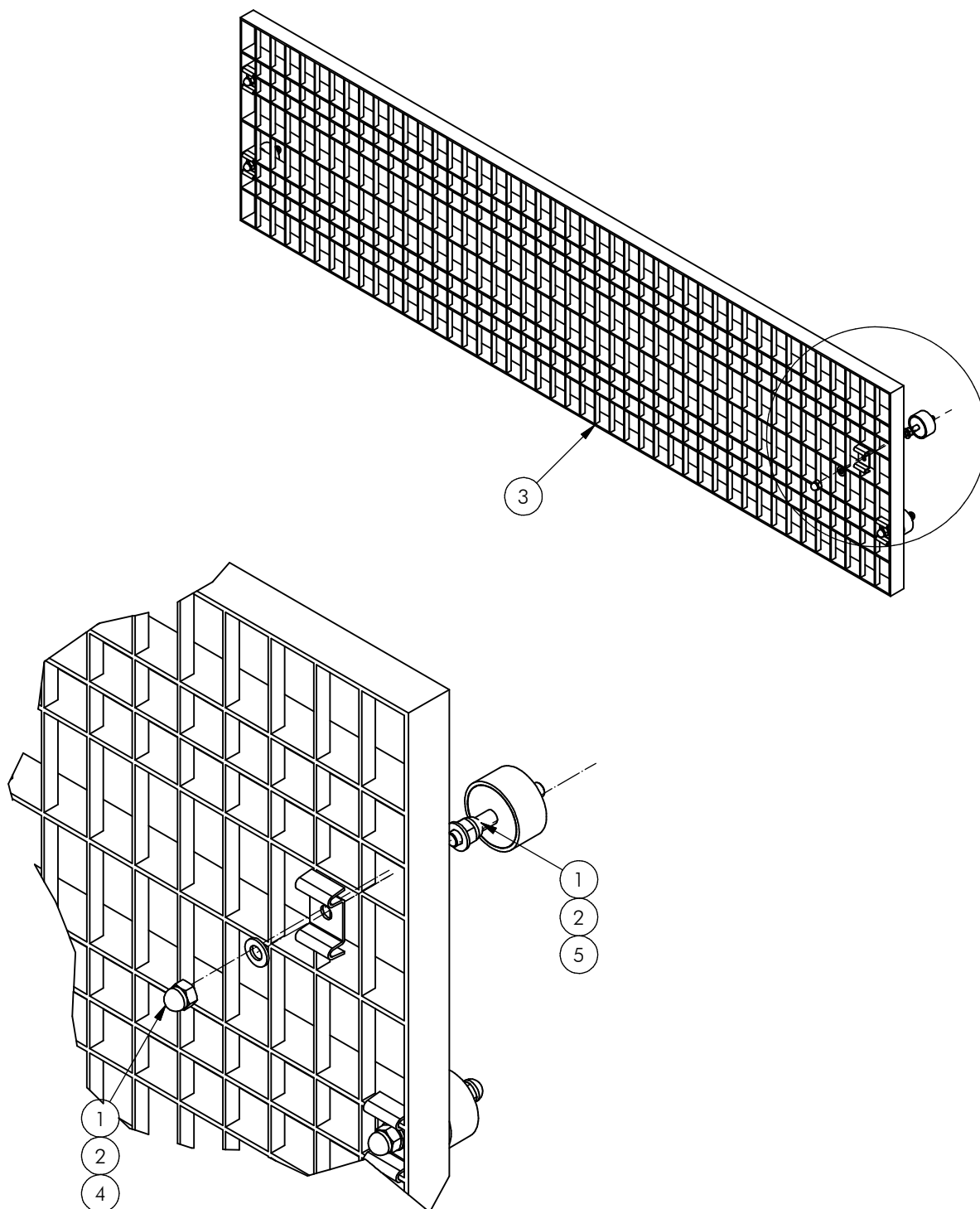

Nr	#	Type	Progr.	Volgnr	Bew.	Rev.	Benaming	Opmerking
1	8	BSV	011	008	015		Borgdopmoer	M8 - VZ 8.8
2	8	BSV	030	008	016		Sluitring	M8 - VZ 8.8
3	1	OME	SPT	108	372	A	persrooster 30,3/3	tbv stramien 1½ x ½
4	4	OME	SPT	114	001		Zadel	SPT
5	4	TNB	MDR	006			Demper 40x20	M8x30/15



Benaming  
Title Persrooster 1,5 x 0,5 m

Opmerking  
Comment Pannaveld

Datum  
Date 30-10-2012

Tekening  
Drawing

**MOD SPT 035 003**

Samenstelling module Assembly module

Samenstelling  
 MOD\_SPT\_037\_005  
 t/m  
 MOD\_SPT\_037\_015

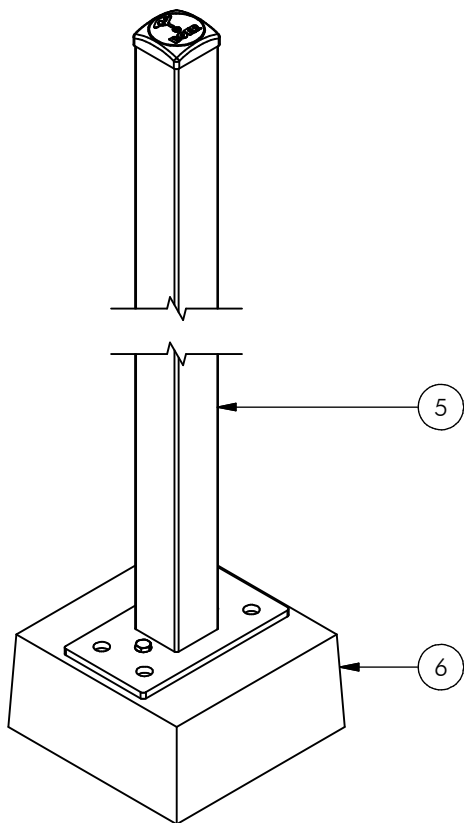

Samenstelling  
 MOD\_SPT\_037\_020  
 t/m  
 MOD\_SPT\_037\_040

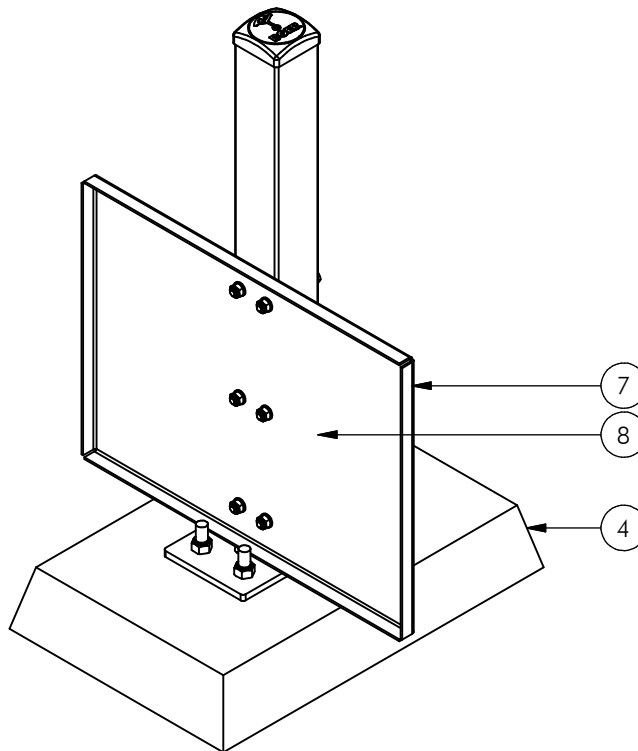

Nr	#	Type	Progr.	Volgnr	Bew.	Rev.	Benaming	Opmerking
1	1	OME	KAP	080	524	A	Paalkap 80x80	Zamak, Ral 5003
2	4	BSV	010	016	016		BORGMOER	M16 - VZ 8.8
3	4	BSV	030	016	003		SLUITRING	M16 x 3
4	1	OBT	POE	010	050		Poermodel 10	50 kg
5	1	BSV	004	005	025		Schroef verz.	5 x 25 - VZ 8.8
6	1	SMD	OBT	009	001		Poer met Moertjes	300 x 300 x 150
7	1	SMD	SPT	000	002		Gronddrukplaat	tbv Palen > 2 mtr
8	1	SME	SPT	038	372	D	SPT Staander	Lengte: Zie 'Las-&BoorStaat'



Benaming  
 Title SPT - Staander met Poer  
 Opmerking  
 Comment Variabele Lengten  
 Datum  
 Date 10-10-2013

Tekening  
 Drawing

**MOD SPT 037 000 A**  
 Samenstelling module Assembly module

Samenstelling  
 MOD\_SPT\_037\_005  
 t/m  
 MOD\_SPT\_037\_015

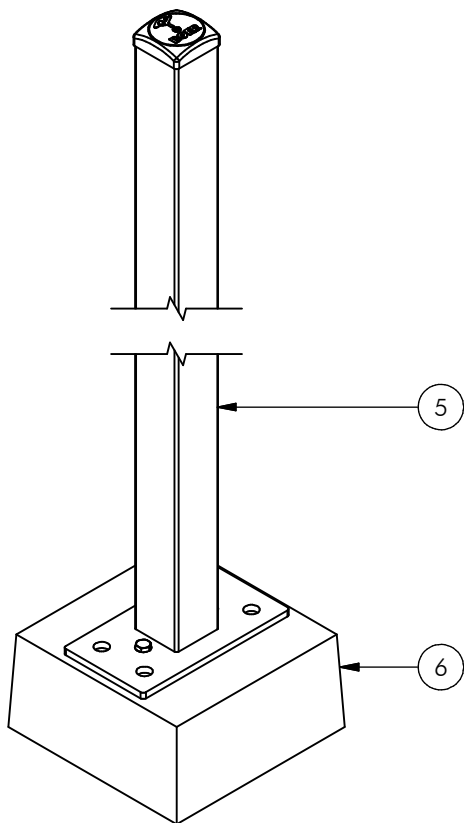

Samenstelling  
 MOD\_SPT\_037\_020  
 t/m  
 MOD\_SPT\_037\_040

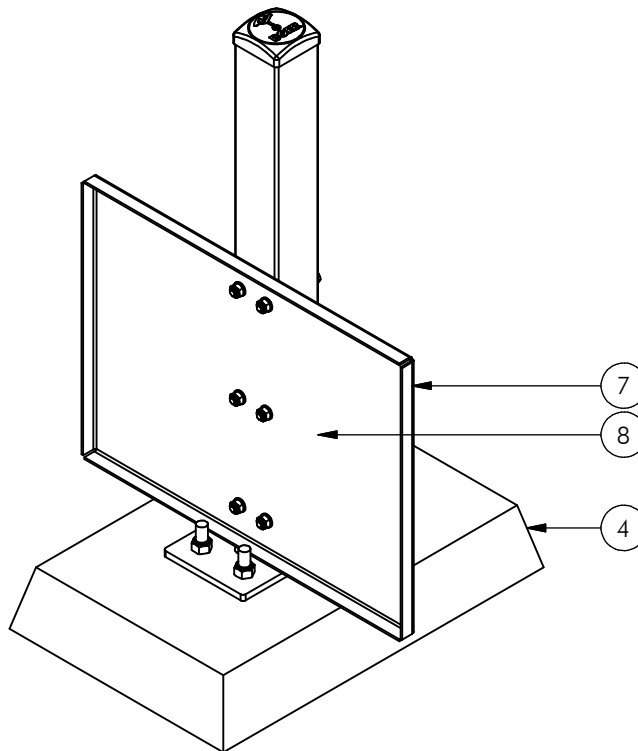

Nr	#	Type	Progr.	Volgnr	Bew.	Rev.	Benaming	Opmerking
1	1	OME	KAP	080	524	A	Paalkap 80x80	Zamak, Ral 5003
2	4	BSV	010	016	016		BORGMOER	M16 - VZ 8.8
3	4	BSV	030	016	003		SLUITRING	M16 x 3
4	1	OBT	POE	010	050		Poermodel 10	50 kg
5	1	BSV	004	005	025		Schroef verz.	5 x 25 - VZ 8.8
6	1	SMD	OBT	009	001		Poer met Moertjes	300 x 300 x 150
7	1	SMD	SPT	000	002		Gronddrukplaat	tbv Palen > 2 mtr
8	1	SME	SPT	038	372	D	SPT Staander	Lengte: Zie 'Las-&BoorStaat'



Benaming  
 Title SPT - Staander met Poer  
 Opmerking  
 Comment Variabele Lengten  
 Datum  
 Date 10-10-2013

Tekening  
 Drawing

**MOD SPT 037 000 A**  
 Samenstelling module Assembly module

Samenstelling  
 MOD\_SPT\_037\_005  
 t/m  
 MOD\_SPT\_037\_015

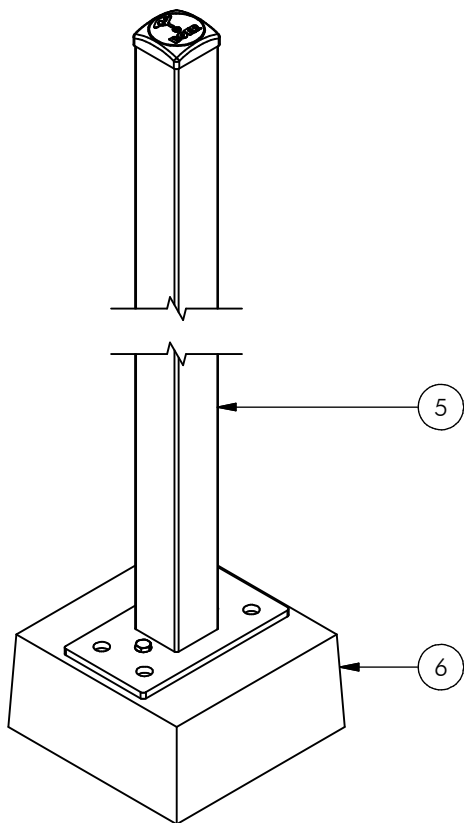

Samenstelling  
 MOD\_SPT\_037\_020  
 t/m  
 MOD\_SPT\_037\_040

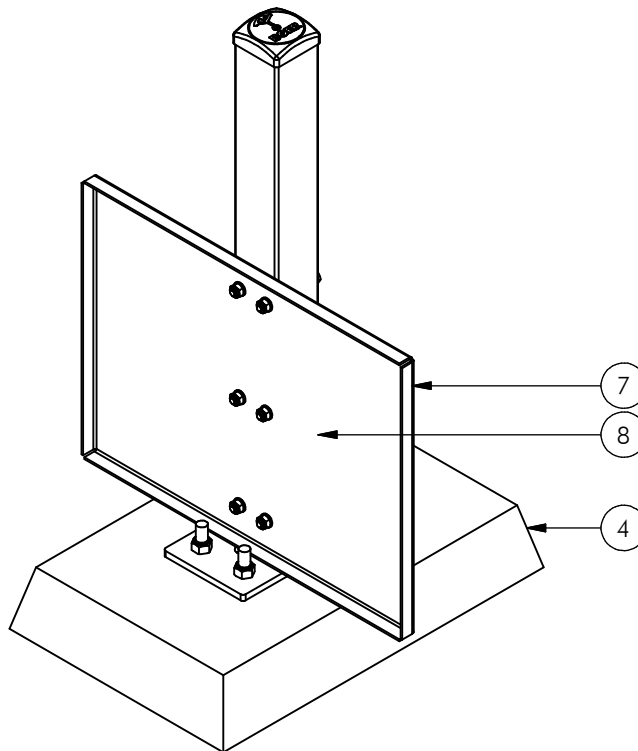

Nr	#	Type	Progr.	Volgnr	Bew.	Rev.	Benaming	Opmerking
1	1	OME	KAP	080	524	A	Paalkap 80x80	Zamak, Ral 5003
2	4	BSV	010	016	016		BORGMOER	M16 - VZ 8.8
3	4	BSV	030	016	003		SLUITRING	M16 x 3
4	1	OBT	POE	010	050		Poermodel 10	50 kg
5	1	BSV	004	005	025		Schroef verz.	5 x 25 - VZ 8.8
6	1	SMD	OBT	009	001		Poer met Moertjes	300 x 300 x 150
7	1	SMD	SPT	000	002		Gronddrukplaat	tbv Palen > 2 mtr
8	1	SME	SPT	038	372	D	SPT Staander	Lengte: Zie 'Las-&BoorStaat'



Benaming  
 Title SPT - Staander met Poer  
 Opmerking  
 Comment Variabele Lengten  
 Datum  
 Date 10-10-2013

Tekening  
 Drawing

**MOD SPT 037 000 A**  
 Samenstelling module Assembly module

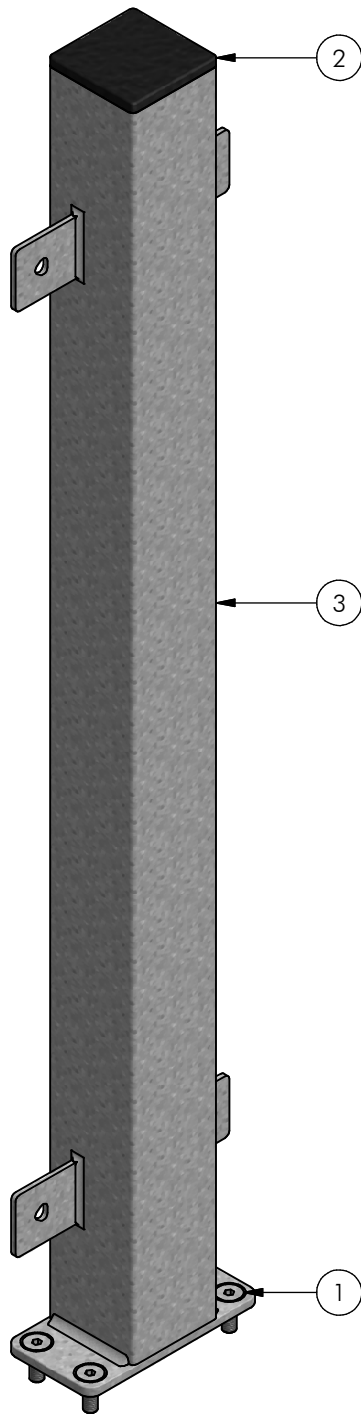

Nr	#	Type	Progr.	Volgnr	Bew.	Rev.	Benaming	Opmerking
1	4	BSV	024	010	030		Verzonken bout	M10 x 30 - VZ 8.8
2	1	KST	LAM	080	080		Lamellenstop	80 x 80 mm
3	1	SME	SPT	049	372	A	Paal op Goal	L 1014



Benaming  
Title Paal op Maxi Goal

Opmerking  
Comment tbv H 3,0 m

Datum  
Date 30-10-2012

Tekening  
Drawing

# MOD SPT 037 230

Samenstelling module *Assembly module*