

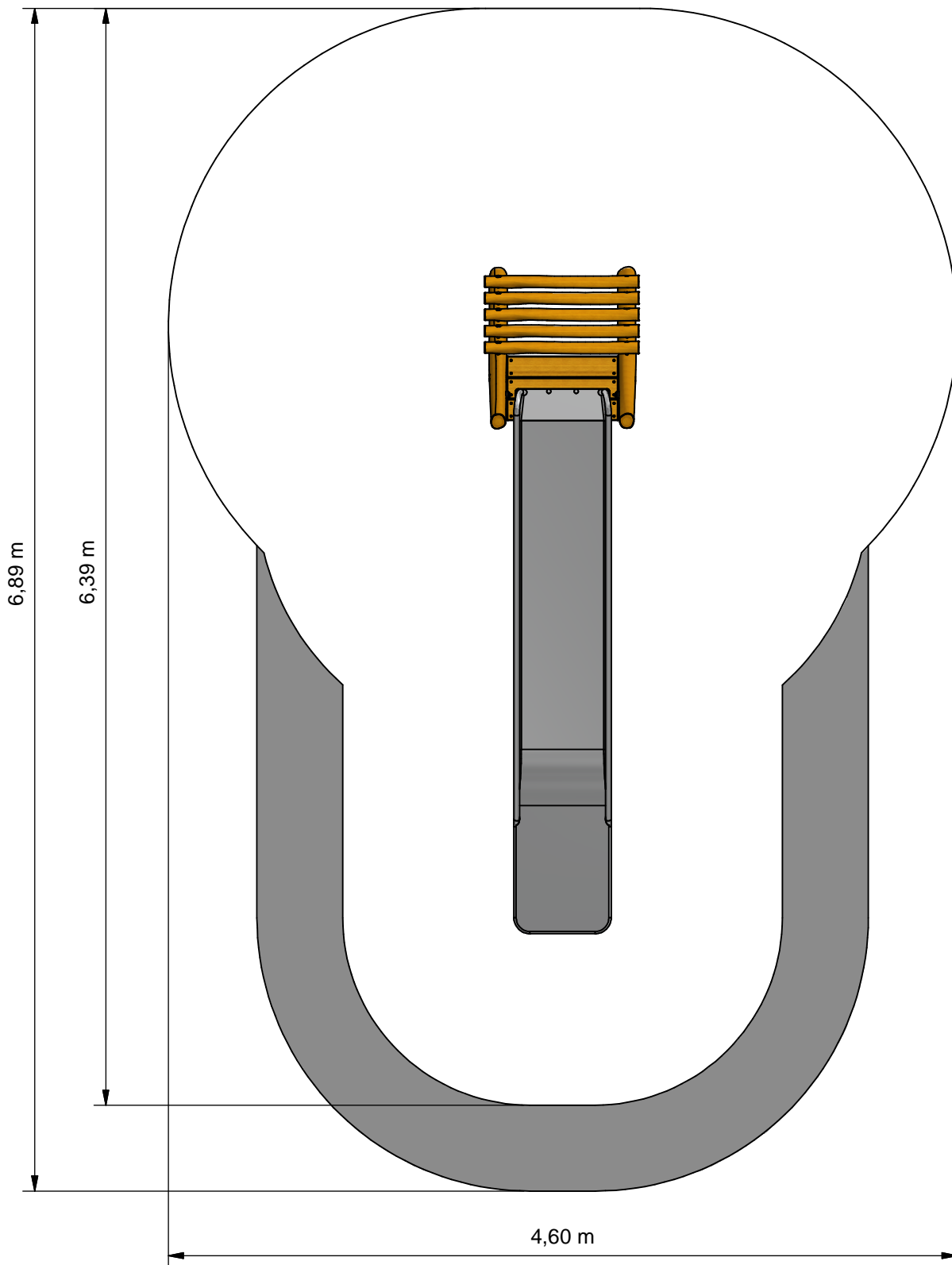

# Slide



**PSTE000.233**



- Opvangzone  
Impact area
- Obstakelvrije zone  
Obstacle free zone



Benaming  
Title: Glijbaan

Opmerking  
Comment: Vrijstaand 1,95 m

Datum  
Date: 21-12-2012

Tekening  
Drawing

**TOE PST 000 233**

Obstakelvrije zone *Obstacle free zone*

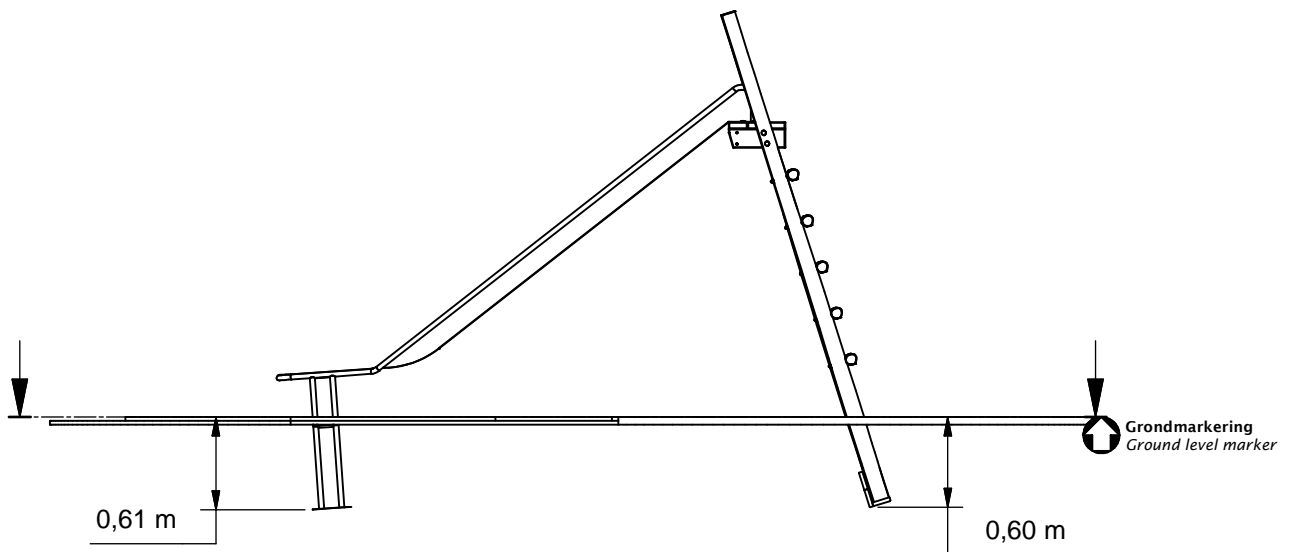
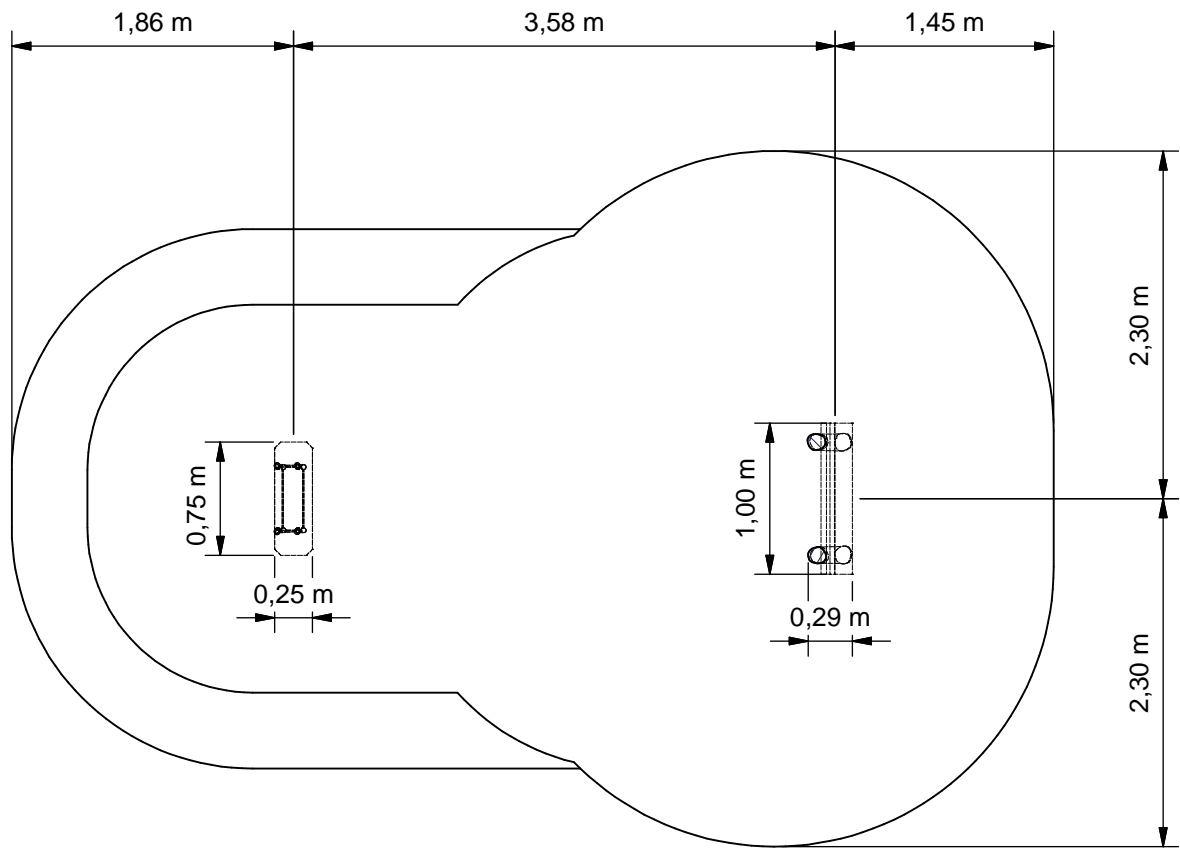

Benaming  
Title | Glijbaan

Opmerking  
Comment | Vrijstaand 1,95 m

Datum  
Date | 21-12-2012

Tekening  
Drawing

TOE PST 000 233

Bodemplan *Groundplan*

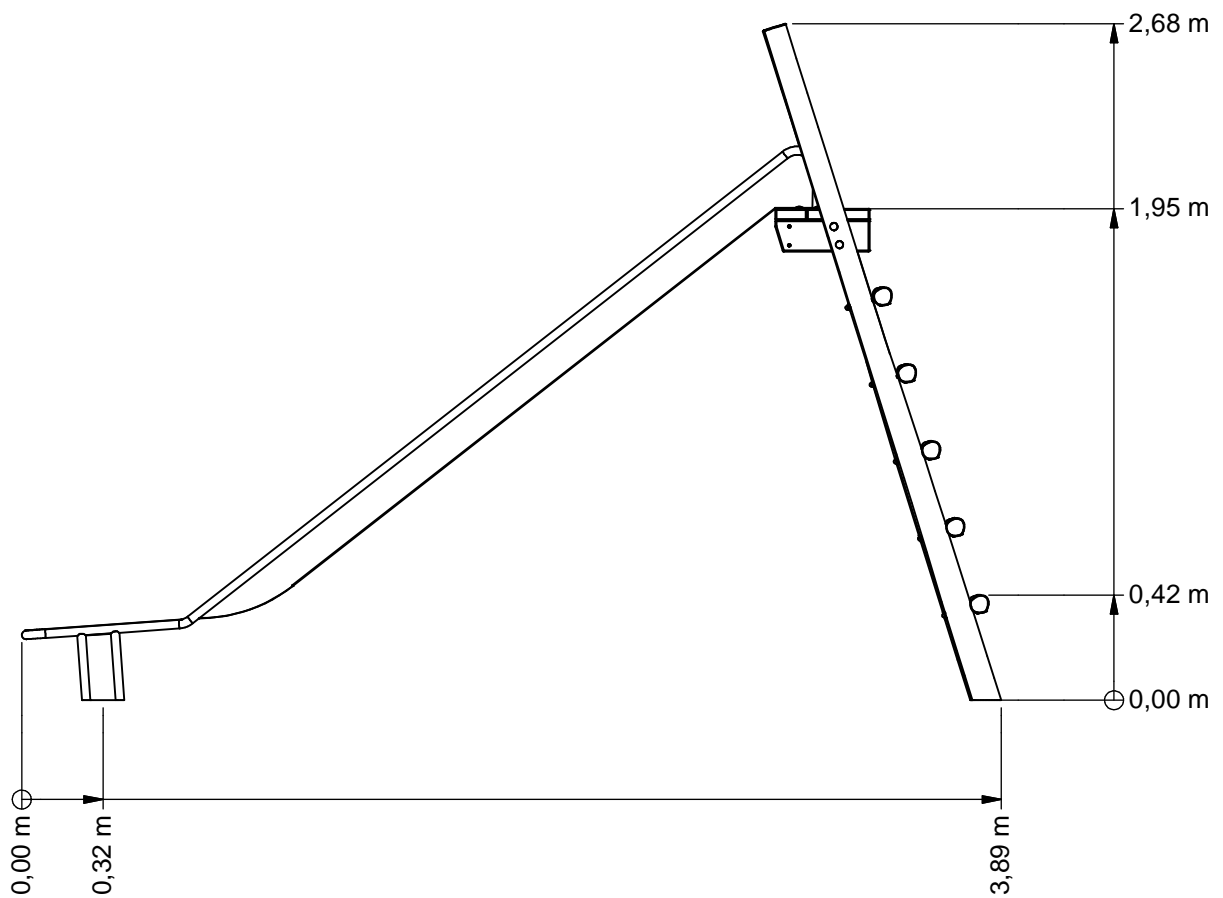
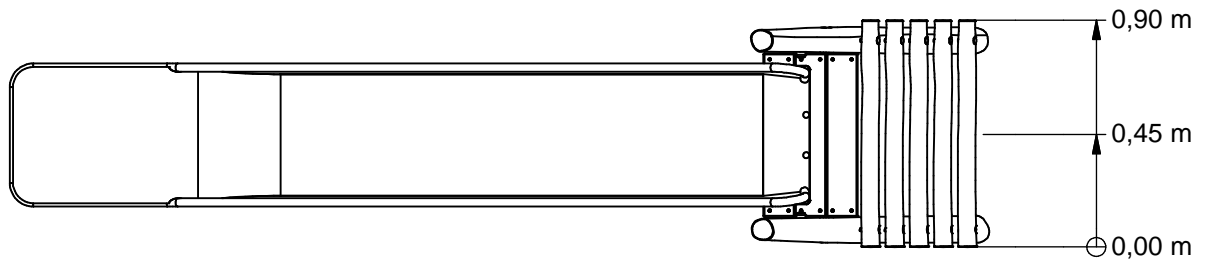

Benaming  
Title | Glijbaan

Opmerking  
Comment | Vrijstaand 1,95 m

Datum  
Date | 21-12-2012

Tekening  
Drawing

TOE PST 000 233

Afmetingen Dimensions

**Geleverde modules:**

Zie tabel

**Supplied modules:**

See table

**Montageinstructie:**

- De hoofdmaten geven de maten van de standers en vloeren aan
- De detailtekeningen geven specifiek de maten van de verbindingen aan
- De modules met buizen zijn op de tekeningen bemaat op bovenkant kopplaat
- Overige modules zijn bemaat op de bovenkant (klimwanden, paalkappen, etc.)

**Assembly instruction:**

- The main dimensions indicate the dimensions of the posts and floors
- The detailed dimensions show the specific dimensions of the connections
- The modules which contain tubes are dimensioned at the top of the flanges
- Other modules are dimensioned at the top (climbing walls, caps for the posts, etc.)

**Montagevolgorde:**

- 1 - Graaf de gaten volgens het bodemplan
- 2 - Plaats 1
- 3 - Plaats 2, verbind deze aan 1
- 4 - Controleer of het toestel voldoet aan de afmetingen zoals op blad 'afmetingen'
- 5 - Dicht de gaten en verdicht het zand

**Assembly sequence:**

- 1 - Dig the holes according to the ground plan
- 2 - Place 1
- 3 - Place 2, attach it to 1
- 4 - Check that the equipment conforms to the dimensions shown on sheet 'dimensions'
- 5 - Close the holes and compact the sand

**Controles:**

- 1 - Correcte opbouw en alle bevestigingsmiddelen
- 2 - Controleer de afmetingen van de valbodem t.o.v. het toestel

**Checks:**

- 1 - Correct assembly and all the fasteners
- 2 - Check the dimensions of the safety area with regard to the play equipment

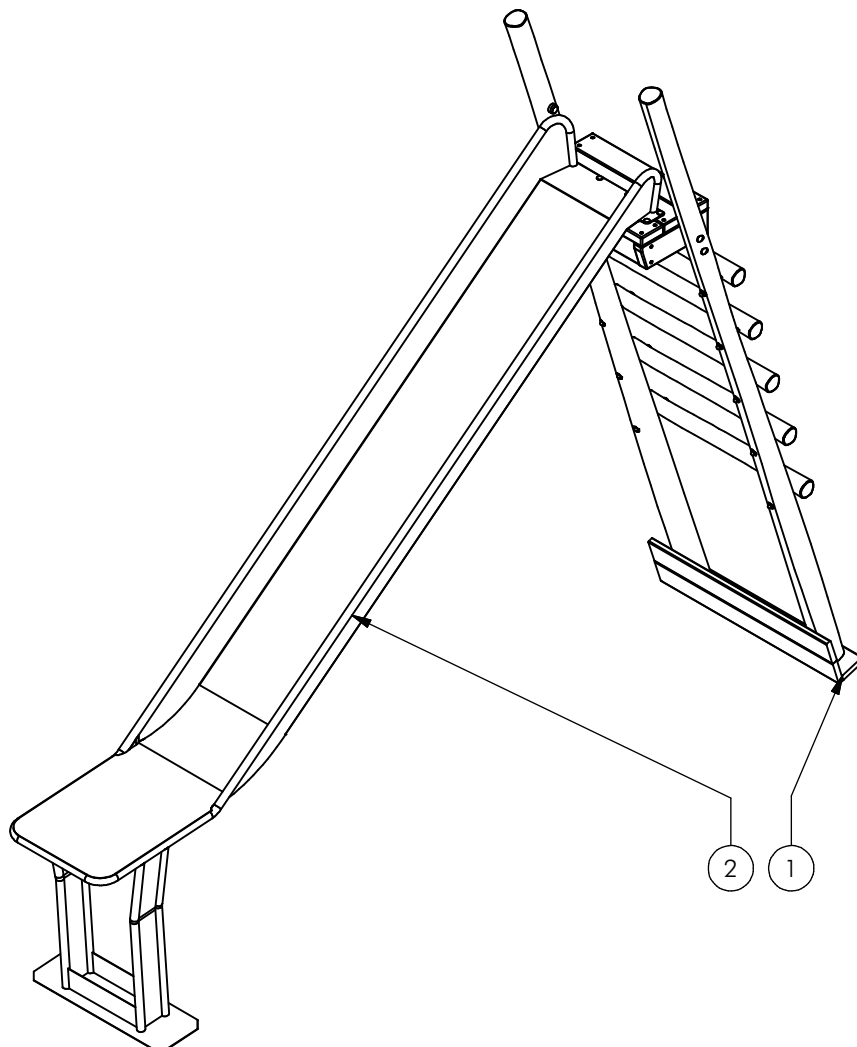

Nr	#	Type	Progr.	Volgnr	Bew.	Rev.	Benaming	Opmerking
1	1	MOD	PST	002	013		Trap glijbaan	195 cm
2	1	MOD	PST	002	193		Glijbaan 195 cm	Module Robina



Benaming  
Title | Glijbaan

Opmerking  
Comment | Vrijstaand 1,95 m

Datum  
Date | 21-12-2012

Tekening  
Drawing

TOE PST 000 233

Modules Modules

# PSTE000.233

Slide

## LOGBOOK

(Onderstaand logboek kan gebruikt worden om te voldoen aan de eisen, gesteld in artikel 14 van het Warenwetbesluit Attractie- en Speeltoestellen)

Type indication	Adventure Play
Product code	PSTE000.233
Name of equipment	Glijbaan vrijstaand 1,80-1,95m
Maximum height of fall	2,0 m
Year of construction	2017
Certificate	033887
inspection authority	TUV Nederland QA BV De Waal 21c, Best - 5684 PH Best
Name manufacturer	BOERplay Hyacintstraat 2 - 4255 HX Nieuwendijk Phone: +31 (0)183 40 23 66 Fax: +31 (0)183 40 35 64
name installer	_____ _____
Description of equipment	Slide
Location of equipment	_____
Data about the owner of the play equipment	
Name:	_____
Address:	_____
Postcode and town:	_____
Contact person:	_____
Telephone number:	_____
Data about the administrator of the play equipment	
Name:	_____
Address:	_____
Postcode and town:	_____
Contact person:	_____
Telephone number:	_____

# LOGBOOK

## Inspection and maintenance intervals



Nr.	Inspection	Maintenance	months between inspections
1	Verify equipment's stability, junctions and missing parts. Inspect bolts, screws and nuts for absence, jams, corrosion and wear.	Add missing parts, secure joints, apply missing fixing agent and replace corroded parts.	1
2	Check suspension for wear.	Replace worn parts and/or remove non-functioning parts.	1
3	Inspect rotating parts such as hinges, rolling-element bearings, etc. for wear and acceptability.	Replace worn parts and/or remove non-functioning parts.	1
4	Check wood for splinters, unacceptable damage and signs of rot. Especially at ground level.	Repair damage. Replace affected wood. Smoothen splintered wood and sharp edges.	1
5	Inspect foundation for stability, tearing and coverage.	Restore foundation and covering material.	3
6	Examine rubber and synthetic parts for wear, damage and break.	Replace original parts.	3
7	Inspect metal for corrosion and damage in the coating.	Restore any damaged coating (after removing rust and applying primer).	6
8	Check ropes, cables, chains and nets for wear and damage. Steel cables and nets which are tensioned must be checked for tension.	Replace parts where necessary. Steel cables and nets must be tensioned.	3
9	Inspect equipment for unsafe changes and additions.	Remove unsafe additions and correct unsafe changes.	1
10	Inspect safety surfaces.	Restore and repair where necessary.	1

## Remarks

1. If used intensively, all points require extra attention.
2. Extreme weather conditions and locations may require a higher inspection frequency. Discuss this with the supplier.
3. Vandalism-sensitive locations require stricter inspections, possibly daily.
4. Check the terrain regularly for items that do not belong there, are unsafe or may be used wrongly. Examples are poisonous plants, glass shards, etc. Frequency depends on strain.
5. Remember that bad maintenance leads to unsafe conditions and notably faster impoverishment of the playground area.
6. Replacement parts can be ordered at the manufacturer with the part numbers on the module drawing. Drawings can be found in de user guide.
7. The impact area shall be provided with impact attenuating surface according to the specified falling height.
8. This list is conform the CEN-standard "playground equipment and surfacing NEN-EN 1176-7".

Warenwet

# Certificaat van Typeonderzoek Type Examination Certificate

afgegeven door issued by

## TÜV Nederland QA BV



aangewezen bij ministeriële beschikking van  
4 mei 2012, nr. VGP 3113590

commissioned by departmental order  
of 4 May 2012, no. VGP 3113590

Certificaat nr. Certificate nr.	033887TC_20130515	Dossiennr. File nr.	033887TC
Productomschrijving Product description	Glijbaan		
Evt. nadere aanduidingen Further indications	1,80 – 1,95 m		
voor nadere informatie zie bijbehorend rapport met gelijkluidend dossiernr.  for further information see associated report with identical file nr.			
Eigenaar / certificaathouder en adres Owner/certificate holder and address	Boer Speeltoestellen B.V. Hyacintstraat 2 4255 HX Nieuwendijk		
Soort toestel Category of equipment	Speeltoestel / Playground equipment		
Fabrikant Manufacturer	Boer Speeltoestellen B.V. Hyacintstraat 2 4255 HX Nieuwendijk		
Type/Serienummer Type/Serial number	PST.000.233 /	in te vullen door de fabrikant to be filled out by the manufacturer	
Jaar van fabricage Year of construction	vanaf since 2013		
Leverancier Supplier	Boer Speeltoestellen B.V. Hyacintstraat 2 4255 HX Nieuwendijk		
Jaar van leverantie Year of supply		in te vullen door de leverancier to be filled out by the supplier	
Datum keuring Date of examination	04-02-2013 – 15-05-2013		

TÜV Nederland QA BV, de Waal 21C, NL-5684 PH Best verklaart, dat het bovenaangehaalde toestel voldoet aan de vervaardigingvoorschriften genoemd in het Warenwetbesluit attractie- en speeltoestellen (met als leidraad de normatieve documenten NEN-EN 1176:2008).

TÜV Nederland QA BV declares that the here above mentioned equipment meets the safety and health requirements mentioned in the Dutch law "Warenwetbesluit attractie- en speeltoestellen" (guided by normative documents EN 1176:2008).

Namens het bestuur, For the board,  A.C. Boon Directeur	
---	--



Openingen tussen treden  
en bordes controleren,  
tenminste Ø230 mm

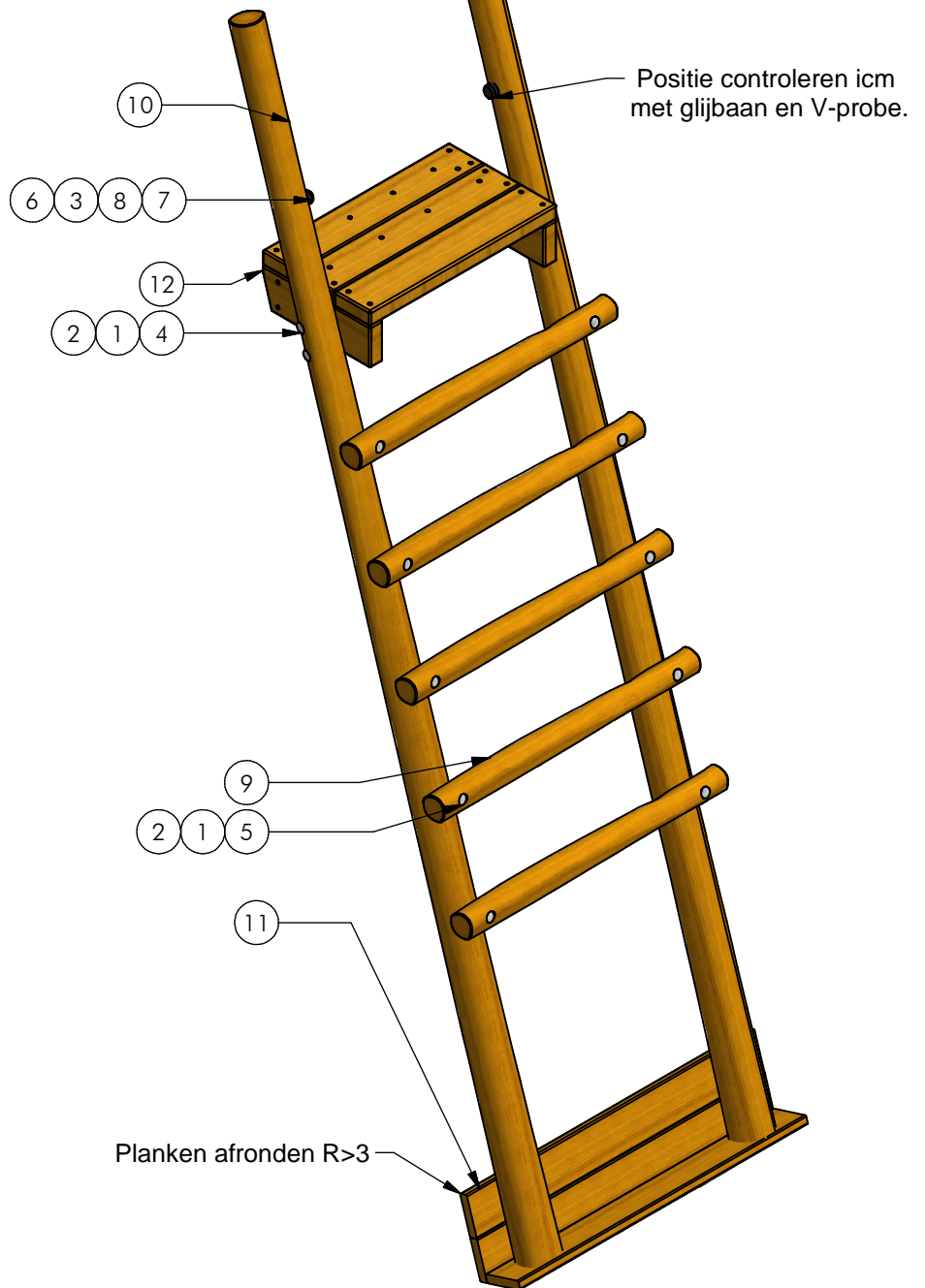
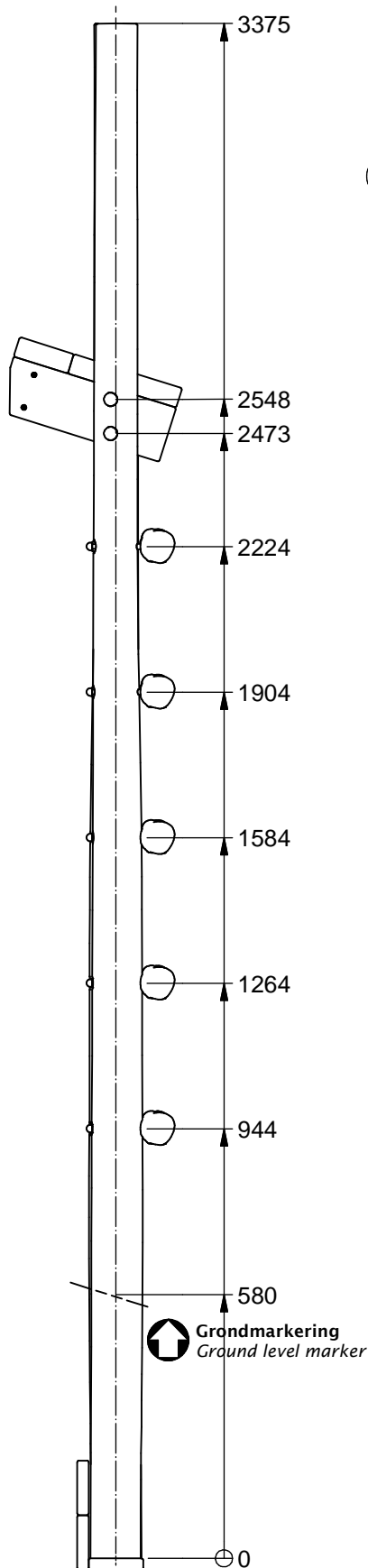

Nr	#	Type	Progr.	Volgnr	Bew.	Rev.	Benaming	Opmerking
1	14	BMR	030	M12	024		Sluitring M12	RVS A2-70
2	14	BSR	011	012	025		Borgdopmoer	M12 - RVS A2-70
3	2	BSR	022	010	050		Houtdraadbout	RVS A2 M10 X 50
4	4	BSR	026	012	150		Slotbout	M12 x 150 - RVS A2-70
5	10	BSR	026	012	180		Slotbout	M12 x 180 - RVS A2-70
6	2	BSR	030	010	002		Sluitring	M10 - RVS A2-70
7	2	KST	DON	010	060		Bescherm dop M10-M12	Donut zwart
8	2	KST	DOP	010	060		Bescherm dop M10-M12	Dop zwart
9	5	OHO	PST	080	009		Paal 6-8	Lengte =900
10	2	OHO	PST	120	034		Paal 10-12	Lengte =3400
11	3	OHO	PST	221	100		Plank 120x25	Lengte = 1000
12	1	SHO	PST	003	230		Startbordes	Glijbaan

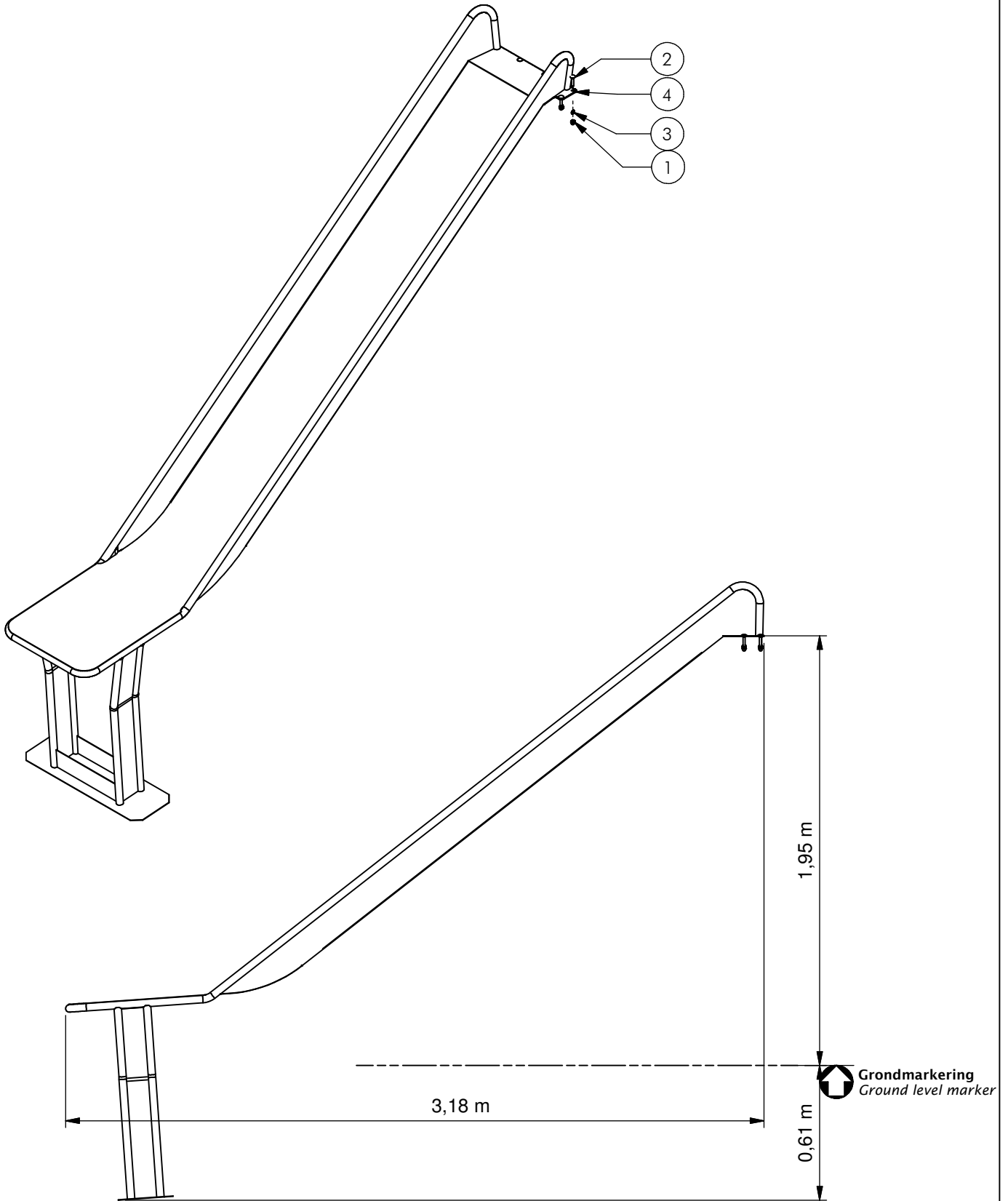

**Let op:** toestel bij voorkeur niet met de glijbaan op het zuiden plaatsen.

**Attention:** it is advisable not to orient playground equipment with the slide facing south

Nr	#	Type	Progr.	Volgnr	Bew.	Rev.	Benaming	Opmerking
1	6	BSR	011	010	020		DOPMOER	BORG RVS M10
2	6	BSR	026	010	050		Slotbout	M10 x 50 - RVS A2-70
3	6	BSR	030	010	002		SLUITRING	M10
4	1	SME	VRB	614	320	C	Glijbaan	195 cm



Benaming  
Title: Glijbaan 195 cm

Opmerking  
Comment: Module Robina

Datum  
Date: 21-12-2012

Tekening  
Drawing

**MOD PST 002 193 A**  
Samenstelling module Assembly module