

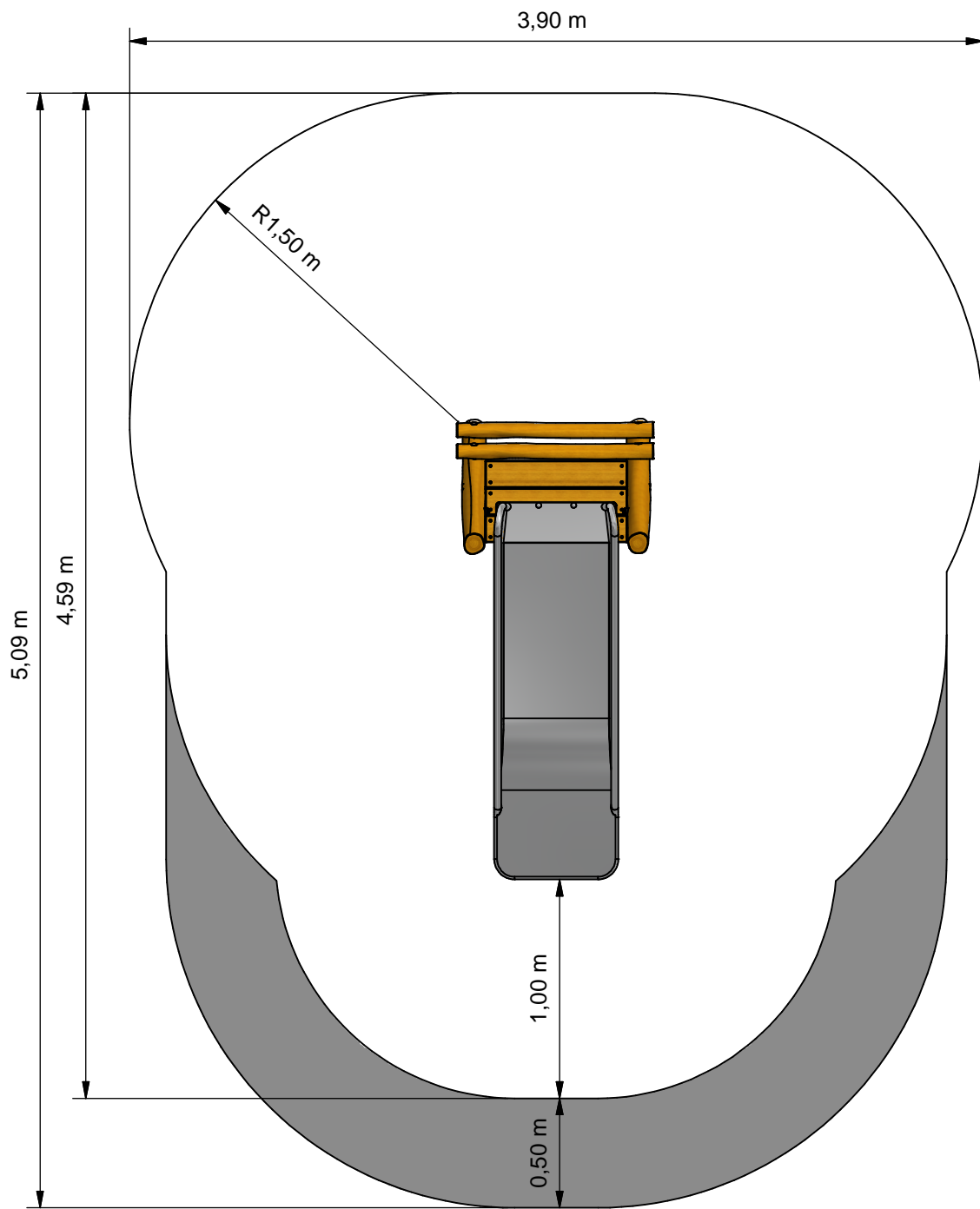



Slide



PSTE000.230



	Opvangzone Impact area
	Obstakelvrije zone Obstacle free zone



Benaming
Title: Glijbaan

Opmerking
Comment: Vrijstaand 1,0 m

Datum
Date: 21-12-2012

Tekening
Drawing

TOE PST 000 230

Obstakelvrije zone *Obstacle free zone*

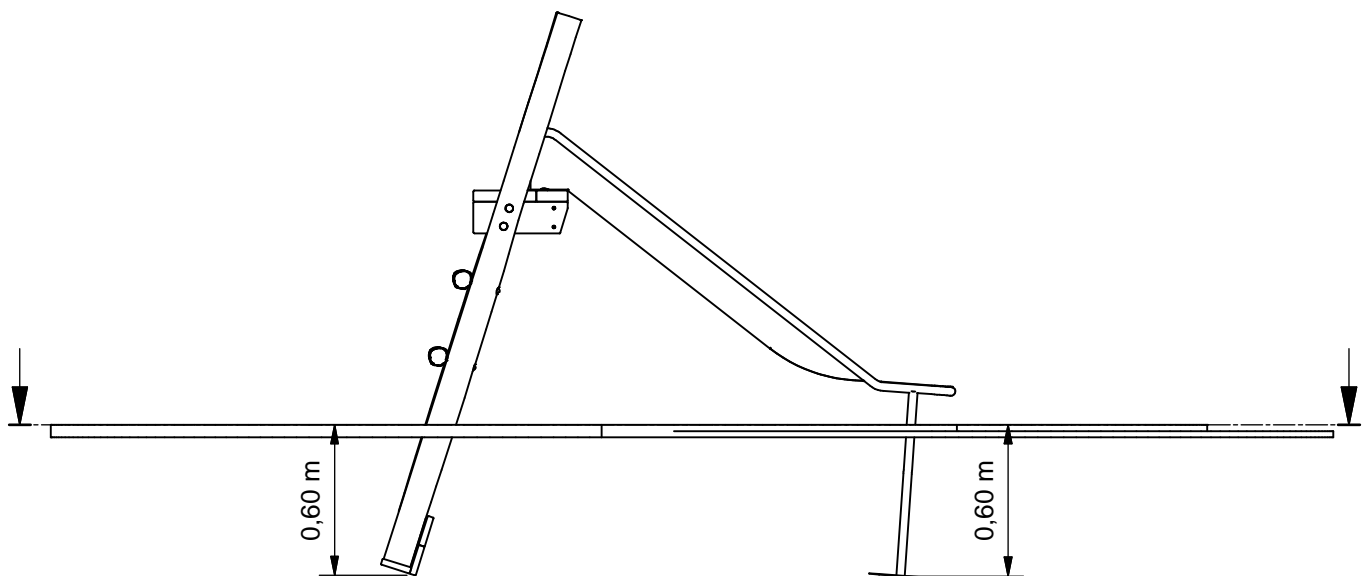
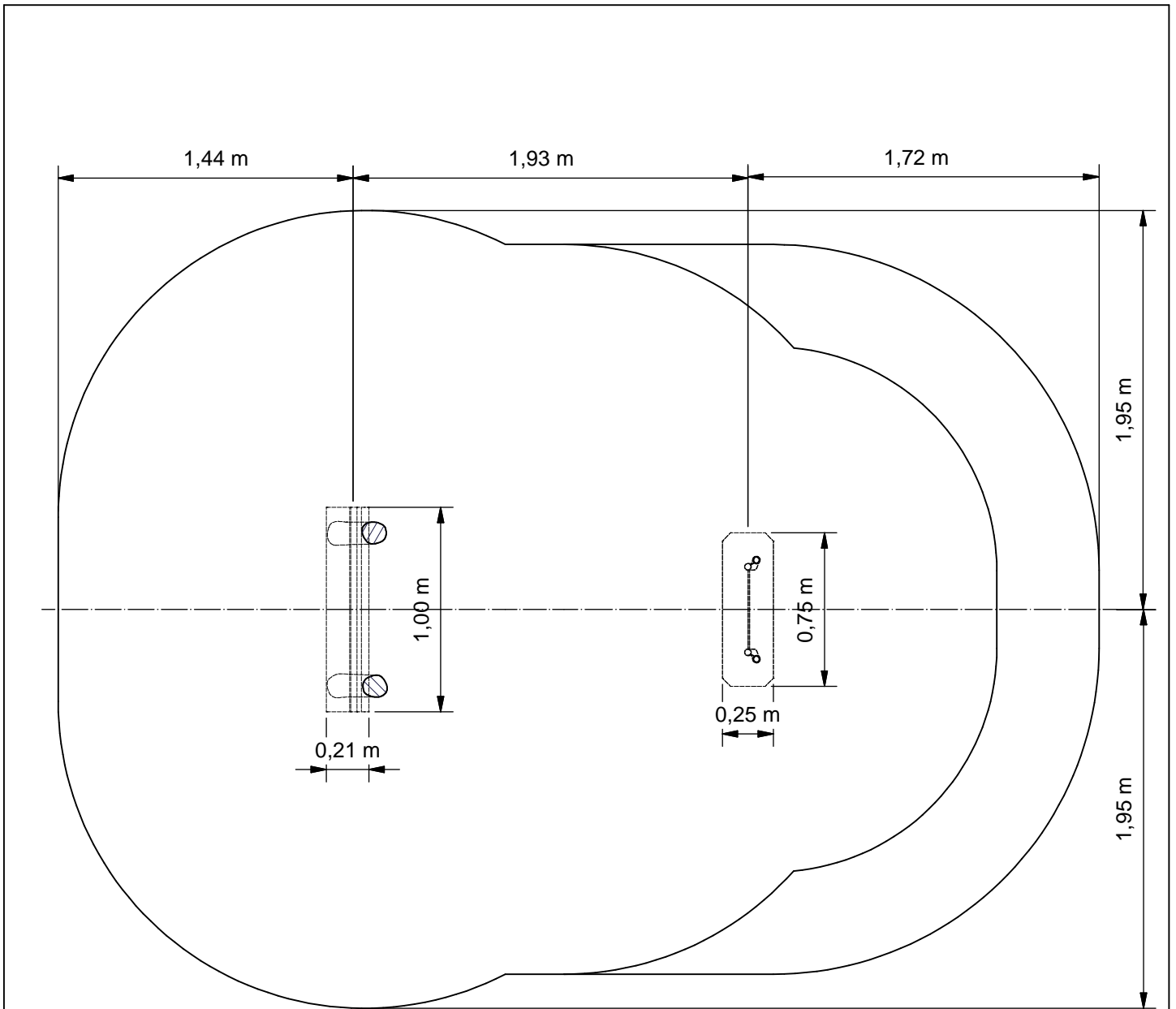

Benaming
 Title Glijbaan
 Opmerking
 Comment Vrijstaand 1,0 m
 Datum
 Date 21-12-2012

Tekening
 Drawing

TOE PST 000 230

Bodemplan *Groundplan*

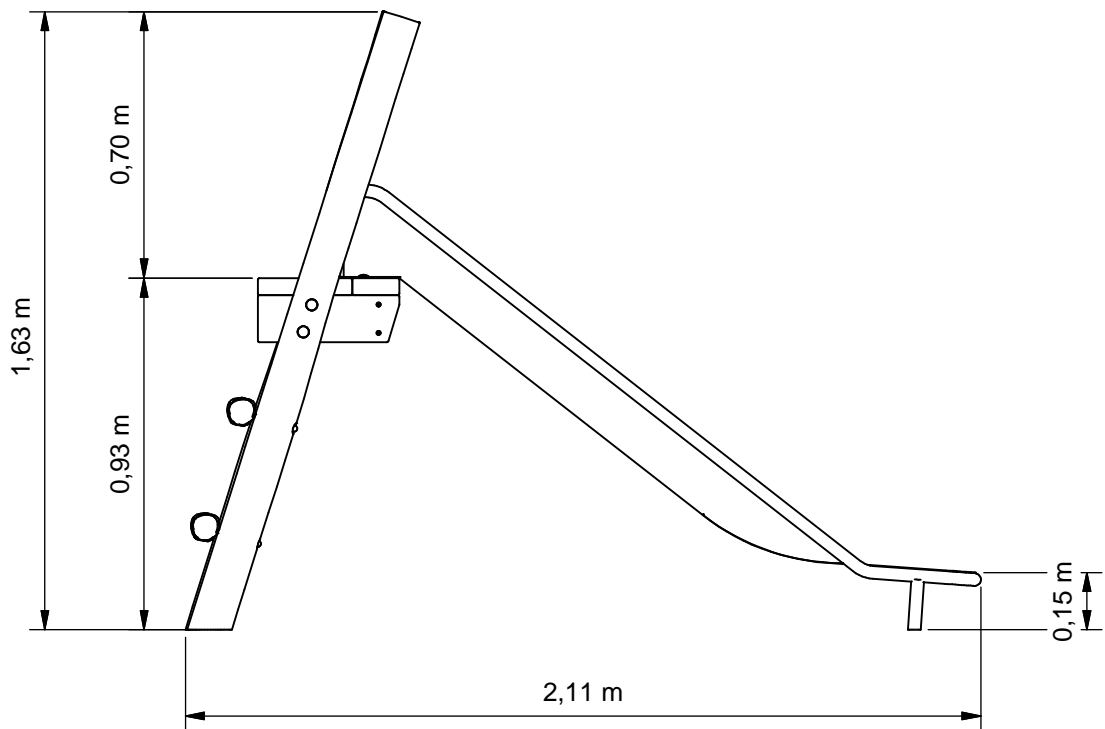
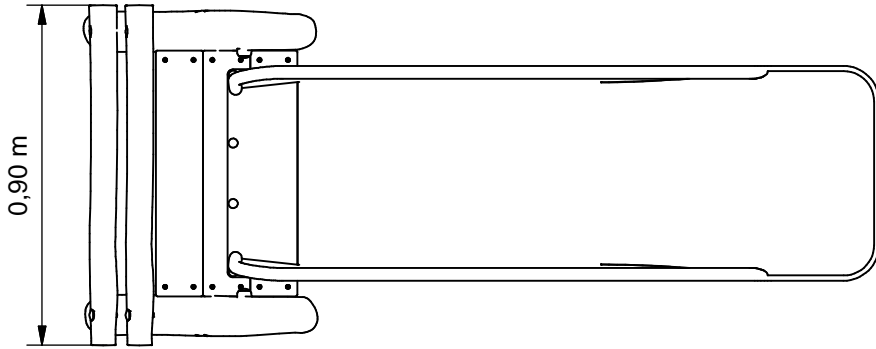

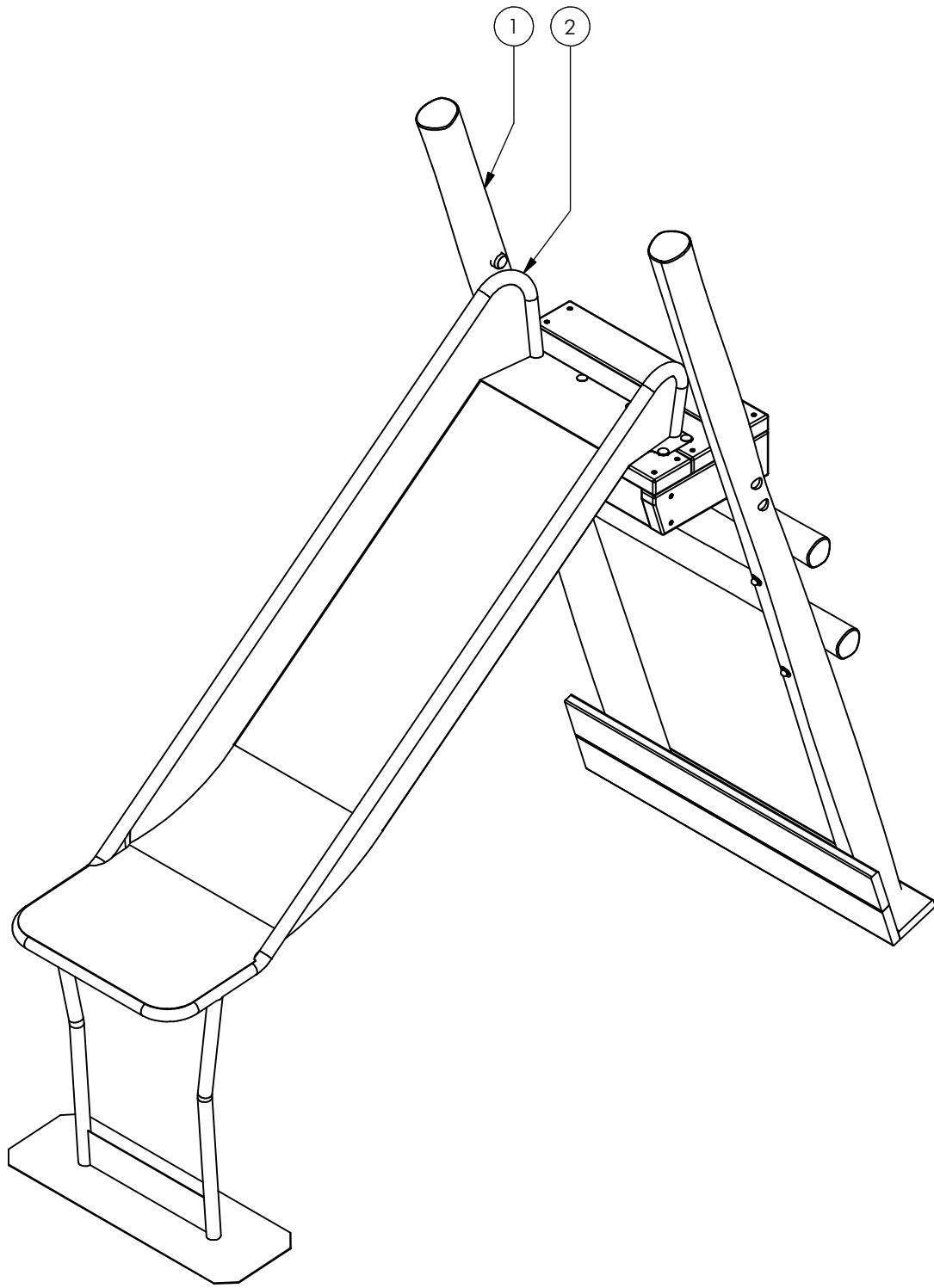

Nr	#	Type	Progr.	Volgnr	Bew.	Rev.	Benaming	Opmerking
1	1	MOD	PST	002	010		Trap glijbaan	93 cm
2	1	MOD	PST	002	190		Glijbaan 1 m	Module Robina



Benaming
Title | Glijbaan

Opmerking
Comment | Vrijstaand 1,0 m

Datum
Date | 21-12-2012

Tekening
Drawing

TOE PST 000 230

Modules Modules

Geleverde delen:

A - ladder
B - glijbaan

Bevestiging sets:

1 - slotbout M10 incl. moer en ring (6x)

Montagevolgorde:

1 - monteer A aan B met set 1 op de voorgeboorde gaten
2 - graaf de gaten volgens het bodemplan en plaats hierin het toestel
3 - controleer of het toestel voldoet aan de afmetingen zoals op blad 'afmetingen'
4 - dicht de gaten en verdicht het zand

Controles:

1 - correcte opbouw en alle bevestigingsmiddelen
2 - de uiterste hoogte van het uiteinde van de glijbaan (<19 cm)
3 - de lengte van het startplatform (35>40 cm)
4 - controleer de afmetingen van de valbodem t.o.v. het toestel

Supplied parts:

A - ladder
B - slide

Mounting kits:

1 - M10 bolt with washer and lock nut (6x)

Assembly sequence:

1 - mount part A to B using set 1 on the pre-drilled holes
2 - dig the holes according to the ground plan and place the play equipment
3 - check that the equipment conforms to the dimensions shown on sheet 'dimensions'
3 - close the holes and compact the sand

Checks:

1 - correct assembly and all the fasteners
2 - the maximum height of the end of the slide (<19 cm)
3 - the minimum length of the starting platform (35>40 cm)
4 - check the dimensions of the safety area compared to the play equipment

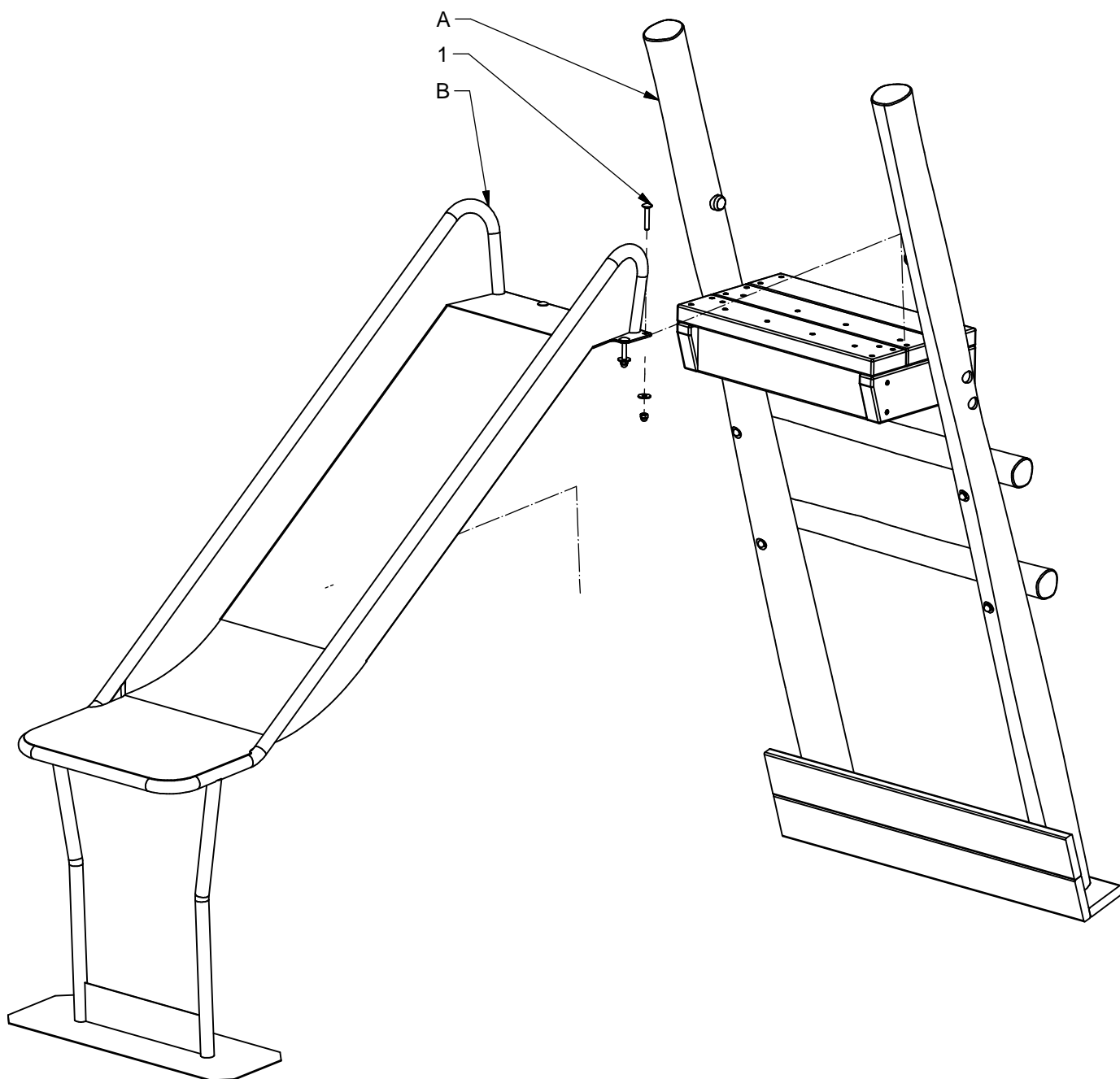

PSTE000.230

Slide

LOGBOOK

(Onderstaand logboek kan gebruikt worden om te voldoen aan de eisen, gesteld in artikel 14 van het Warenwetbesluit Attractie- en Speeltoestellen)

Type indication	Adventure Play
Product code	PSTE000.230
Name of equipment	Glijbaan vrijstaand 0.8 - 0.93
Maximum height of fall	1,0 m
Year of construction	2017
Certificate	033859
inspection authority	TUV Nederland QA BV De Waal 21c, Best - 5684 PH Best
Name manufacturer	BOERplay Hyacintstraat 2 - 4255 HX Nieuwendijk Phone: +31 (0)183 40 23 66 Fax: +31 (0)183 40 35 64
name installer	_____ _____
Description of equipment	Slide
Location of equipment	_____
Data about the owner of the play equipment	
Name:	_____
Address:	_____
Postcode and town:	_____
Contact person:	_____
Telephone number:	_____
Data about the administrator of the play equipment	
Name:	_____
Address:	_____
Postcode and town:	_____
Contact person:	_____
Telephone number:	_____

LOGBOOK

Inspection and maintenance intervals



Nr.	Inspection	Maintenance	months between inspections
1	Verify equipment's stability, junctions and missing parts. Inspect bolts, screws and nuts for absence, jams, corrosion and wear.	Add missing parts, secure joints, apply missing fixing agent and replace corroded parts.	1
2	Check suspension for wear.	Replace worn parts and/or remove non-functioning parts.	1
3	Inspect rotating parts such as hinges, rolling-element bearings, etc. for wear and acceptability.	Replace worn parts and/or remove non-functioning parts.	1
4	Check wood for splinters, unacceptable damage and signs of rot. Especially at ground level.	Repair damage. Replace affected wood. Smoothen splintered wood and sharp edges.	1
5	Inspect foundation for stability, tearing and coverage.	Restore foundation and covering material.	3
6	Examine rubber and synthetic parts for wear, damage and break.	Replace original parts.	3
7	Inspect metal for corrosion and damage in the coating.	Restore any damaged coating (after removing rust and applying primer).	6
8	Check ropes, cables, chains and nets for wear and damage. Steel cables and nets which are tensioned must be checked for tension.	Replace parts where necessary. Steel cables and nets must be tensioned.	3
9	Inspect equipment for unsafe changes and additions.	Remove unsafe additions and correct unsafe changes.	1
10	Inspect safety surfaces.	Restore and repair where necessary.	1

Remarks

1. If used intensively, all points require extra attention.
2. Extreme weather conditions and locations may require a higher inspection frequency. Discuss this with the supplier.
3. Vandalism-sensitive locations require stricter inspections, possibly daily.
4. Check the terrain regularly for items that do not belong there, are unsafe or may be used wrongly. Examples are poisonous plants, glass shards, etc. Frequency depends on strain.
5. Remember that bad maintenance leads to unsafe conditions and notably faster impoverishment of the playground area.
6. Replacement parts can be ordered at the manufacturer with the part numbers on the module drawing. Drawings can be found in de user guide.
7. The impact area shall be provided with impact attenuating surface according to the specified falling height.
8. This list is conform the CEN-standard "playground equipment and surfacing NEN-EN 1176-7".

Warenwet

Certificaat van Typeonderzoek Type Examination Certificate

afgegeven door issued by

TÜV Nederland QA BV



aangewezen bij ministeriële beschikking van
4 mei 2012, nr. VGP 3113590

commissioned by departmental order
of 4 May 2012, no. VGP 3113590

Certificaat nr. Certificate nr.	033859TC_20130515	Dossiernr. File nr.	033859TC
Productomschrijving Product description	Glijbaan		
Evt. nadere aanduidingen Further indications	0,8 – 0,93 m		
voor nadere informatie zie bijbehorend rapport met gelijkloidend dossiernr. for further information see associated report with identical file nr.			
Eigenaar / certificaathouder en adres Owner/certificate holder and address	Boer Speeltoestellen B.V. Hyacintstraat 2 4255 HX Nieuwendijk		
Soort toestel Category of equipment	Speeltoestel / Playground equipment		
Fabrikant Manufacturer	Boer Speeltoestellen B.V. Hyacintstraat 2 4255 HX Nieuwendijk		
Type/Serienummer Type/Serial number	PST.000.230 /	in te vullen door de fabrikant to be filled out by the manufacturer	
Jaar van fabricage Year of construction	vanaf since 2013		
Leverancier Supplier	Boer Speeltoestellen B.V. Hyacintstraat 2 4255 HX Nieuwendijk		
Jaar van leverantie Year of supply	in te vullen door de leverancier to be filled out by the supplier		
Datum keuring Date of examination	04-02-2013 – 15-05-2013		

TÜV Nederland QA BV, de Waal 21C, NL-5684 PH Best verklaart, dat het bovenaangehaalde toestel voldoet aan de vervaardigingvoorschriften genoemd in het Warenwetbesluit attractie- en speeltoestellen (met als leidraad de normatieve documenten NEN-EN 1176:2008).

TÜV Nederland QA BV declares that the here above mentioned equipment meets the safety and health requirements mentioned in the Dutch law "Warenwetbesluit attractie- en speeltoestellen" (guided by normative documents EN 1176:2008).

Namens het bestuur, For the board, A.C. Boon Directeur	
---	--

Openingen tussen treden
en bordes controleren,
tenminste Ø230 mm

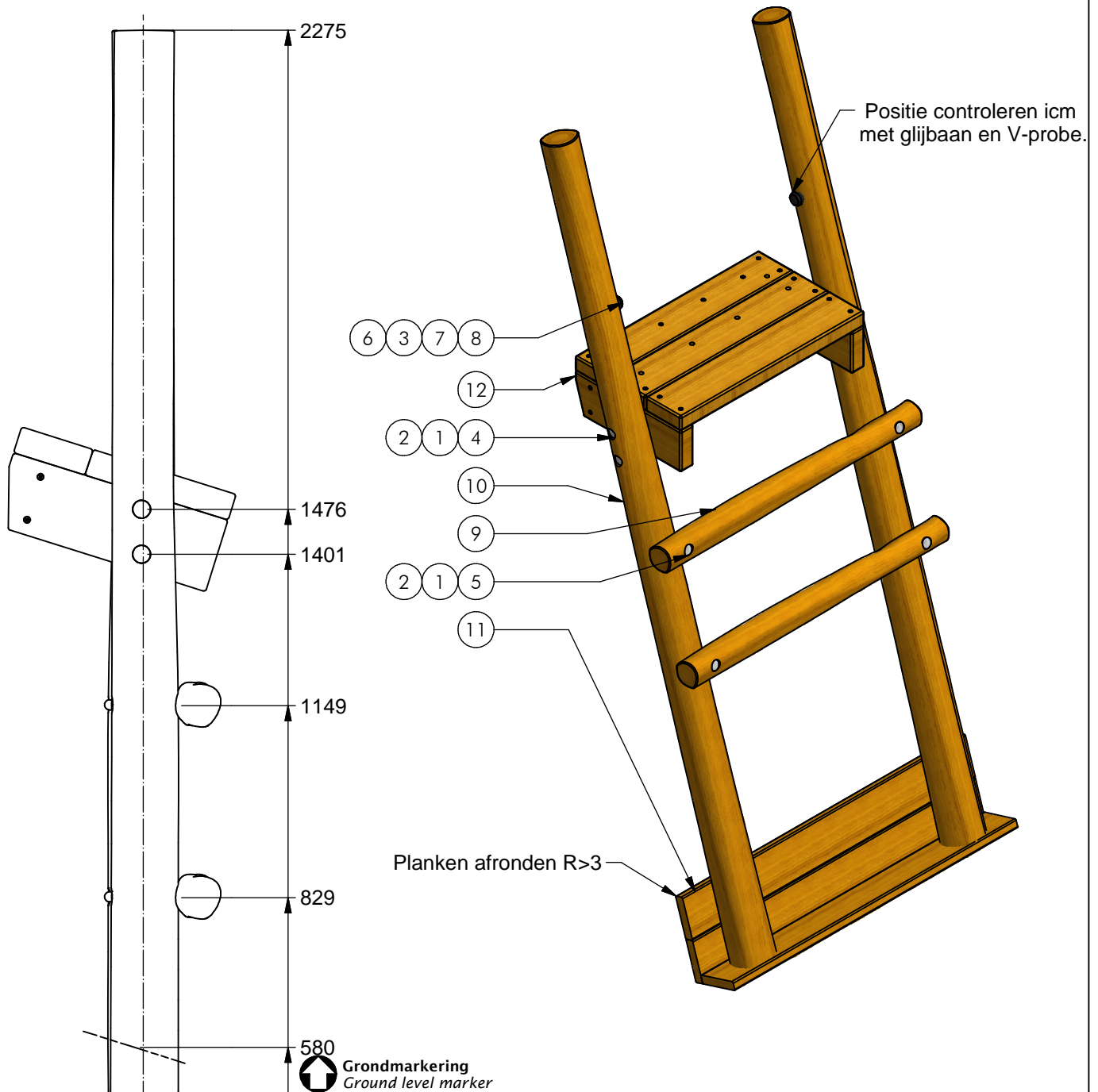

Nr	#	Type	Progr.	Volgnr	Bew.	Rev.	Benaming	Opmerking
1	8	BMR	030	M12	024		Sluitring M12	RVS A2-70
2	8	BSR	011	012	025		Borgdopmoer	M12 - RVS A2-70
3	2	BSR	022	010	050		Houtdraadbout	RVS A2 M10 X 50
4	4	BSR	026	012	150		Slotbout	M12 x 150 - RVS A2-70
5	4	BSR	026	012	180		Slotbout	M12 x 180 - RVS A2-70
6	2	BSR	030	010	002		Sluitring	M10 - RVS A2-70
7	2	KST	DON	010	060		Bescherm dop M10-M12	Donut zwart
8	2	KST	DOP	010	060		Bescherm dop M10-M12	Dop zwart
9	2	OHO	PST	080	009		Paal 6-8	Lengte =900
10	2	OHO	PST	120	023		Paal 10-12	Lengte =2300
11	3	OHO	PST	221	100		Plank 120x25	Lengte = 1000
12	1	SHO	PST	003	230		Startbordes	Glijbaan

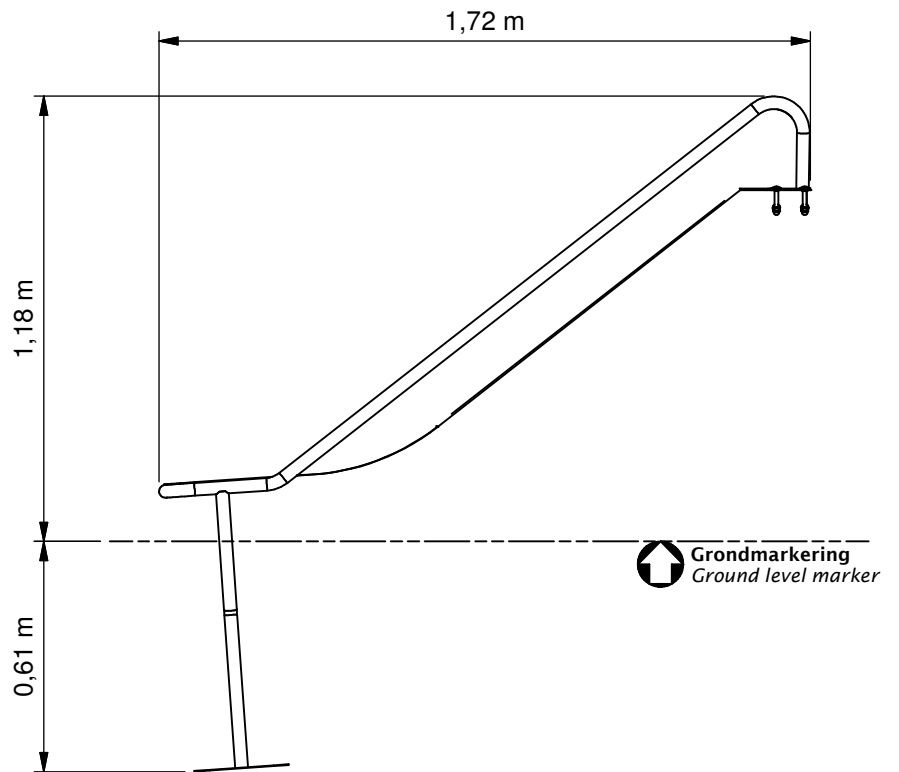
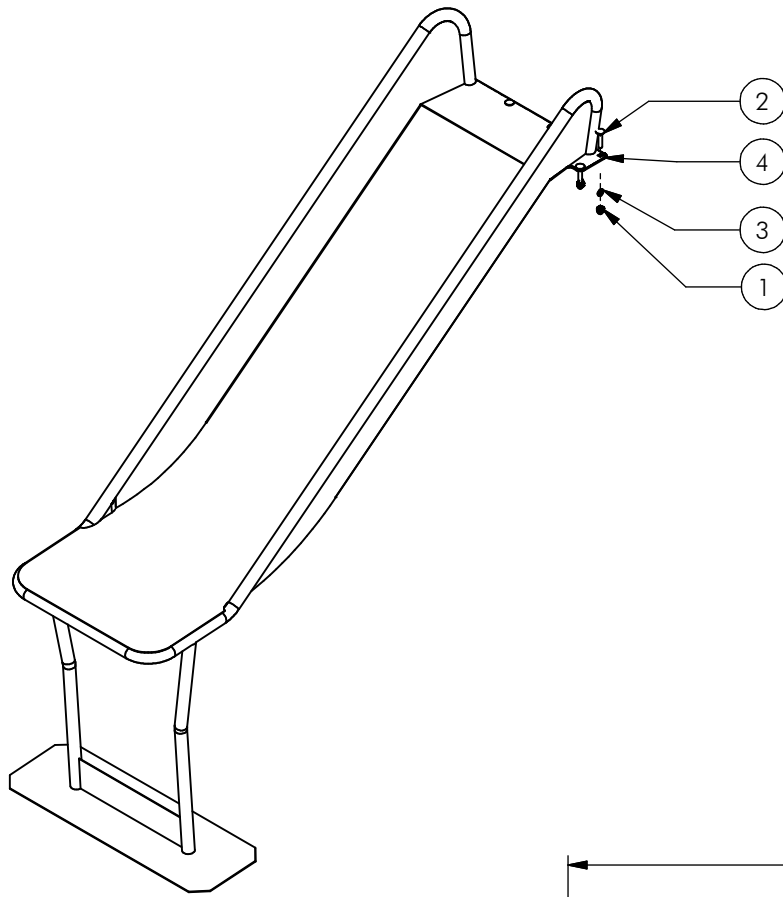

Let op: toestel bij voorkeur niet met de glijbaan op het zuiden plaatsen.

Attention: it is advisable not to orient playground equipment with the slide facing south

Nr	#	Type	Progr.	Volgnr	Bew.	Rev.	Benaming	Opmerking
1	6	BSR	011	010	020		DOPMOER	BORG RVS M10
2	6	BSR	026	010	050		Slotbout	M10 x 50 - RVS A2-70
3	6	BSR	030	010	002		SLUITRING	M10
4	1	SME	VRB	611	320	B	Glijbaan	93 cm



Benaming
Title: Glijbaan 1 m

Opmerking
Comment: Module Robina

Datum
Date: 20-8-2013

Tekening
Drawing

MOD PST 002 190 A
Samenstelling module Assembly module