

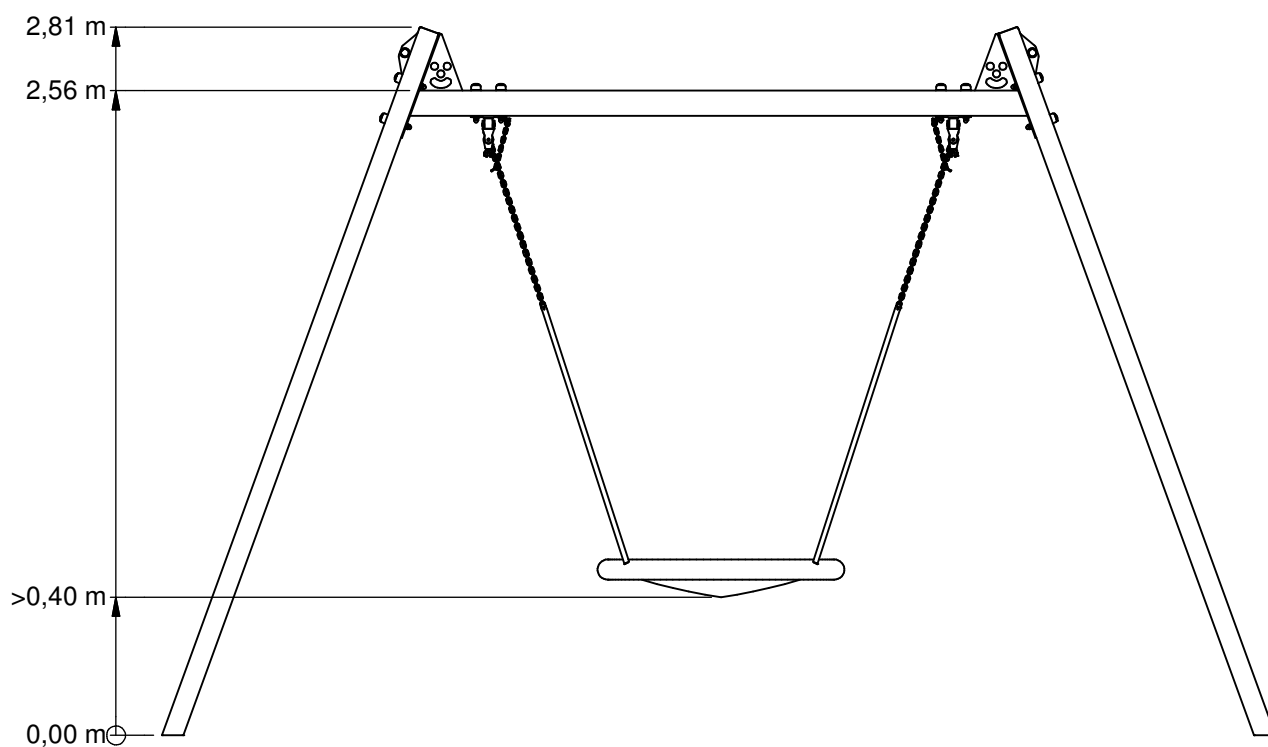

Metal swing with bird's nest

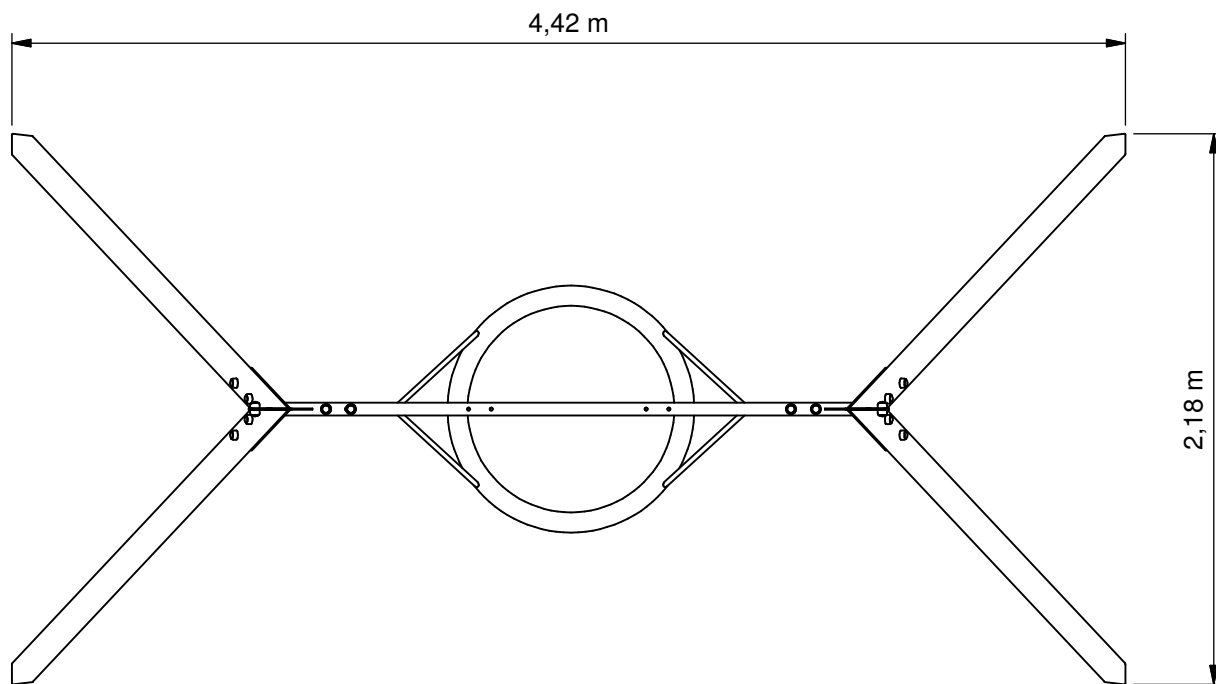

SOLE030.106



Benaming
Title Swoeng metal

Opmerking
Comment Vogelnest

Datum
Date 15-12-2014

Tekening
Drawing

TOE SOL 030 106 B

Hoofdafmetingen *Main dimensions*

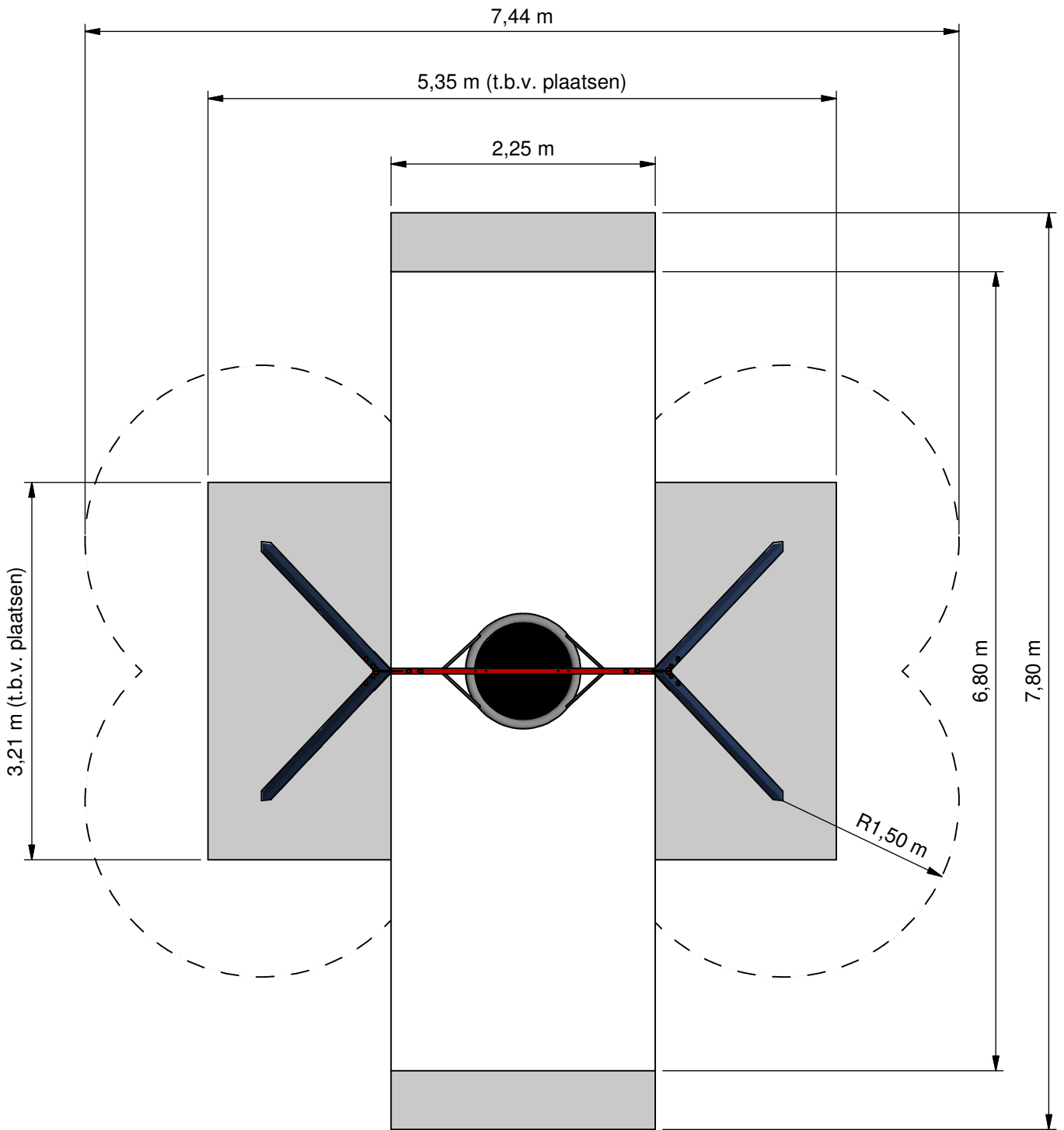

- Obstakelvrij EN-1176**
Obstacle free EN-1176
- Opvangzone**
Impact area
- Obstakelvrij WAS**
Obstacle free WAS



Benaming
Title Swoeng metal

Opmerking
Comment Vogelnest

Datum
Date 15-12-2014

Tekening
Drawing

TOE SOL 030 106 B
Obstakelvrije zone *Obstacle free zone*

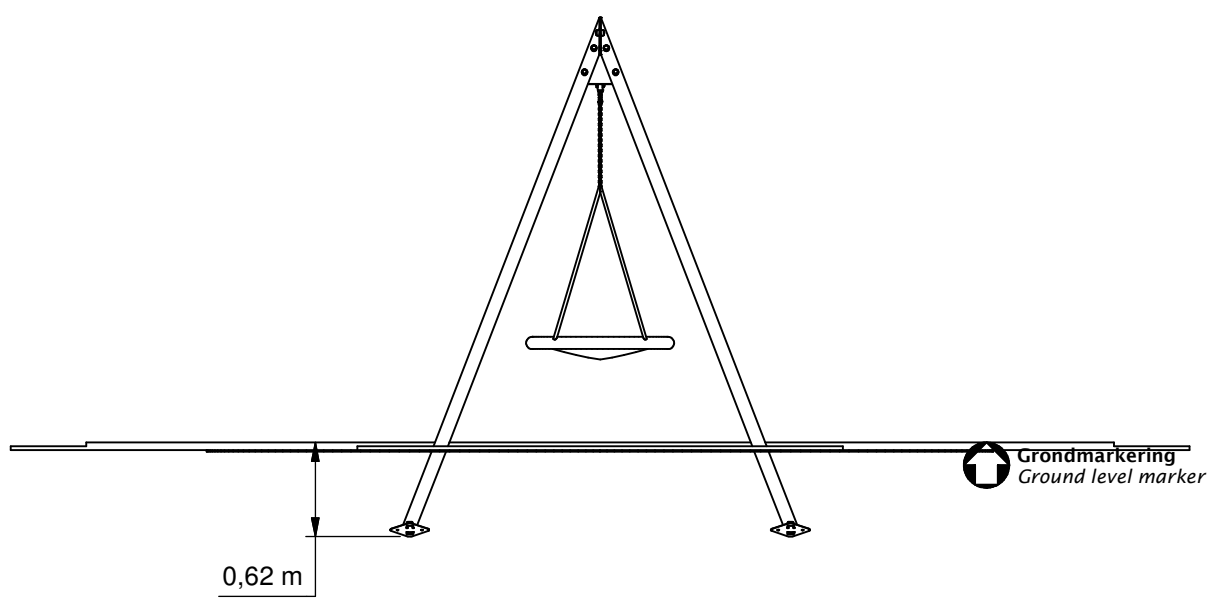
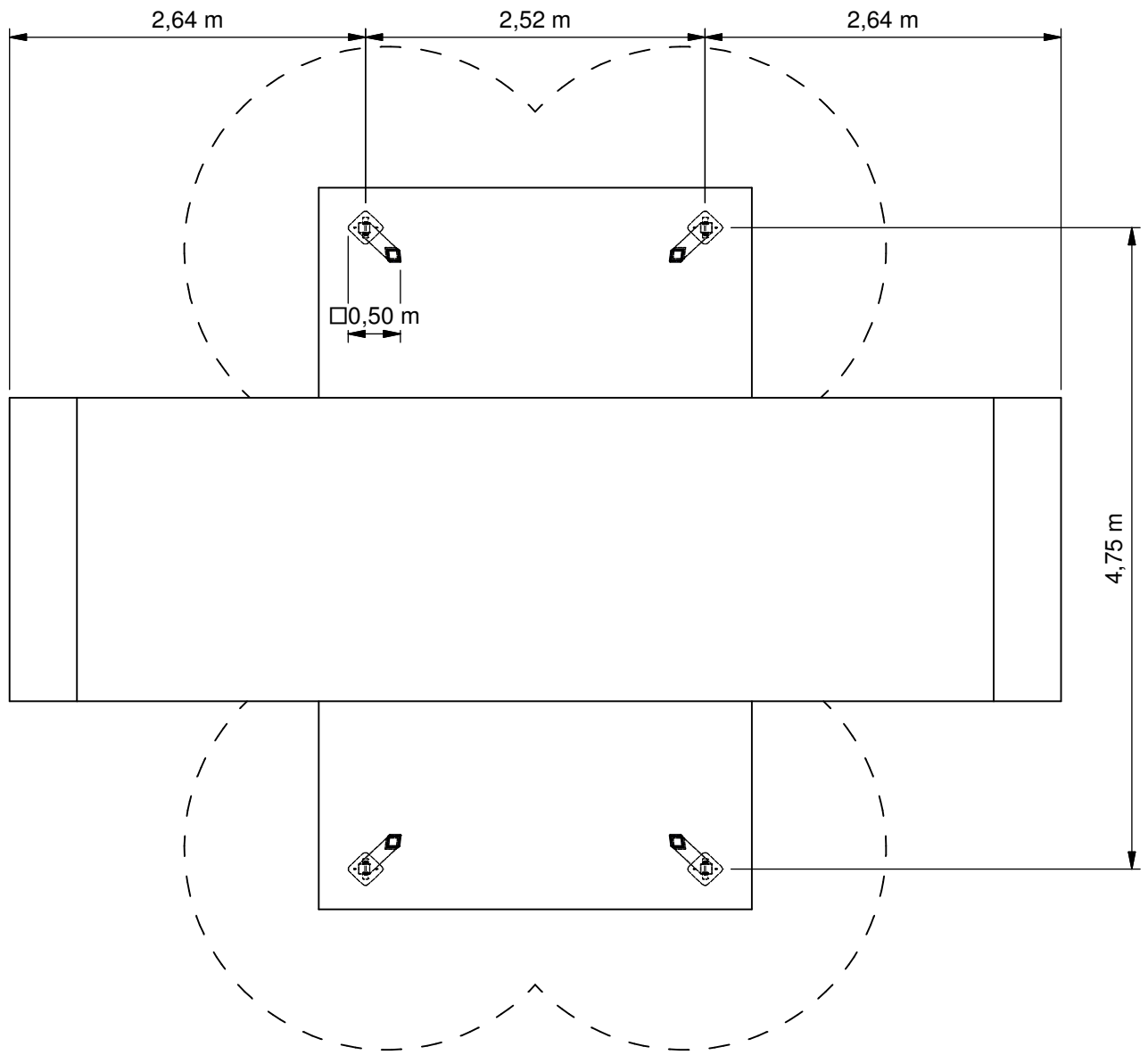

Benaming
Title Swoeng metal

Opmerking
Comment Vogelnest

Datum
Date 15-12-2014

Tekening
Drawing

TOE SOL 030 106 B

Bodemplan Groundplan

Geleverde modules:

Zie tabel

Supplied modules:

See table

Montageinstructie:

- De hoofdmaten geven de maten van de standers en vloeren aan
- De detailtekeningen geven specifiek de maten van de verbindingen aan
- De modules met buizen zijn op de tekeningen bemaat op bovenkant kopplaat
- Overige modules zijn bemaat op de bovenkant (klimwanden, paalkoppen, etc.)

Assembly instruction:

- The main dimensions indicate the dimensions of the posts and floors
- The detailed dimensions show the specific dimensions of the connections
- The modules which contain tubes are dimensioned at the top of the flanges
- Other modules are dimensioned at the top (climbing walls, caps for the posts, etc.)

Montagevolgorde:

- 1 - Graaf de gaten volgens het bodemplan
- 2 - Paats 2
- 3 - Bevestig 1 aan 2
- 4 - Controleer of het toestel voldoet aan de afmetingen zoals op blad 'afmetingen'
- 5 - Dicht de gaten en verdicht het zand

Assembly sequence:

- 1 - Dig the holes according to the ground plan
- 2 - Place 2
- 3 - Attach 1 to 2
- 4 - Check that the equipment conforms to the dimensions shown on sheet 'dimensions'
- 5 - Close the holes and compact the sand

Controles:

- 1 - Correcte opbouw en alle bevestigingsmiddelen
- 2 - Controleer de afmetingen van de valbodem t.o.v. het toestel

Checks:

- 1 - Correct assembly and all the fasteners
- 2 - Check the dimensions of the safety area with regard to the play equipment

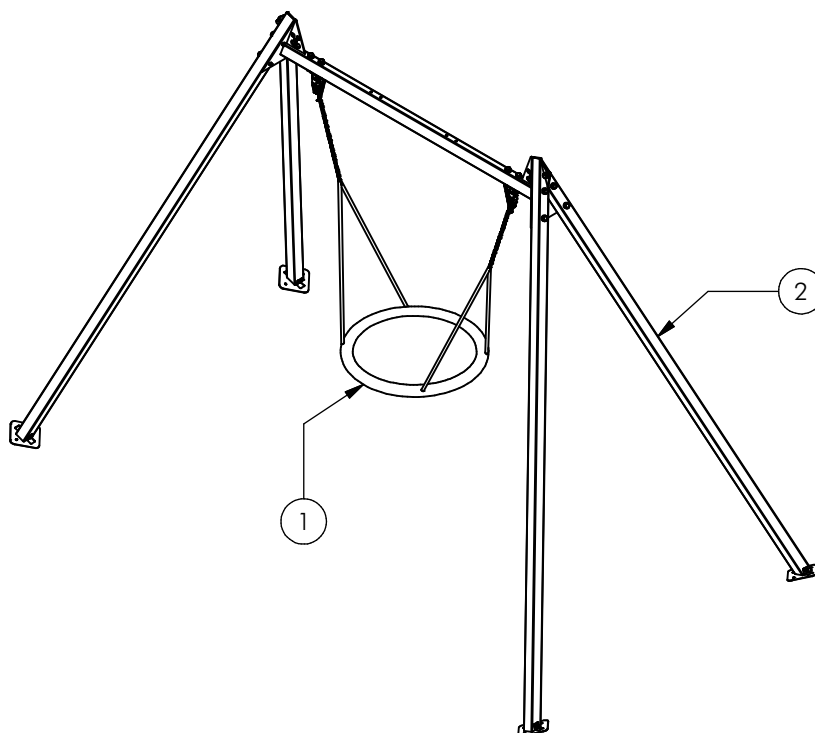

Nr.	#	Type	Progr.	Volgnr.	Bew.	Rev.	Benaming	Opmerking
1	1	MOD	SOL	030	380	B	Vogelnest 1,0 m	Schommelzitje
2	1	MOD	SOL	368	001	A	Schommelframe	Metal dubbel



Benaming
Title Swoeng metal

Opmerking
Comment Vogelnest

Datum
Date 15-12-2014

Tekening
Drawing

TOE SOL 030 106 B

Modules Modules

SOLE030.106

Metal swing with bird's nest

LOGBOOK

(Onderstaand logboek kan gebruikt worden om te voldoen aan de eisen, gesteld in artikel 14 van het Warenwetbesluit Attractie- en Speeltoestellen)

Type indication	Classic Play
Product code	SOLE030.106
Name of equipment	Vogelnestschommel metaal
Maximum height of fall	1,5 m
Year of construction	2017
Certificate	09200116202
inspection authority	Liftinstituut B.V. Buikslotermeerplein 381, A'dam - 1025 XE Amsterdam
Name manufacturer	BOERplay Hyacintstraat 2 - 4255 HX Nieuwendijk Phone: +31 (0)183 40 23 66 Fax: +31 (0)183 40 35 64
name installer	_____ _____
Description of equipment	Metal swing with bird's nest
Location of equipment	_____
Data about the owner of the play equipment	
Name:	_____
Address:	_____
Postcode and town:	_____
Contact person:	_____
Telephone number:	_____
Data about the administrator of the play equipment	
Name:	_____
Address:	_____
Postcode and town:	_____
Contact person:	_____
Telephone number:	_____

LOGBOOK

Inspection and maintenance intervals



Nr.	Inspection	Maintenance	months between inspections
1	Verify equipment's stability, junctions and missing parts. Inspect bolts, screws and nuts for absence, jams, corrosion and wear.	Add missing parts, secure joints, apply missing fixing agent and replace corroded parts.	1
2	Check suspension for wear.	Replace worn parts and/or remove non-functioning parts.	1
3	Inspect rotating parts such as hinges, rolling-element bearings, etc. for wear and acceptability.	Replace worn parts and/or remove non-functioning parts.	1
4	Check wood for splinters, unacceptable damage and signs of rot. Especially at ground level.	Repair damage. Replace affected wood. Smoothen splintered wood and sharp edges.	1
5	Inspect foundation for stability, tearing and coverage.	Restore foundation and covering material.	3
6	Examine rubber and synthetic parts for wear, damage and break.	Replace original parts.	3
7	Inspect metal for corrosion and damage in the coating.	Restore any damaged coating (after removing rust and applying primer).	6
8	Check ropes, cables, chains and nets for wear and damage. Steel cables and nets which are tensioned must be checked for tension.	Replace parts where necessary. Steel cables and nets must be tensioned.	3
9	Inspect equipment for unsafe changes and additions.	Remove unsafe additions and correct unsafe changes.	1
10	Inspect safety surfaces.	Restore and repair where necessary.	1

Remarks

1. If used intensively, all points require extra attention.
2. Extreme weather conditions and locations may require a higher inspection frequency. Discuss this with the supplier.
3. Vandalism-sensitive locations require stricter inspections, possibly daily.
4. Check the terrain regularly for items that do not belong there, are unsafe or may be used wrongly. Examples are poisonous plants, glass shards, etc. Frequency depends on strain.
5. Remember that bad maintenance leads to unsafe conditions and notably faster impoverishment of the playground area.
6. Replacement parts can be ordered at the manufacturer with the part numbers on the module drawing. Drawings can be found in de user guide.
7. The impact area shall be provided with impact attenuating surface according to the specified falling height.
8. This list is conform the CEN-standard "playground equipment and surfacing NEN-EN 1176-7".

TYPE-EXAMINATION CERTIFICATE

Acting under the "Warenwetbesluit Attractie- en Speeltoestellen" issued by Liftinstituut B.V.
commissioned by departmental order, no. VGP/PSL 2857566 from 27 Juni 2008.

Certificate nr. : NL 09-100316202 Revision nr.: 1

Description of the product : Swoeng, playground equipment swing in hardwood or INOX

Trademark, type : Boer Speeltoestellen
TOE SOL 030 016 TOE SOL 030 018
TOE SOL 030 019 TOE SOL 030 022
TOE SOL 030 106 TOE SOL 030 108

Name and address of the manufacturer : Boer Speeltoestellen
Hyacinthstraat 2
4255 HX Nieuwendijk

Name and address of the certificate holder : Boer Speeltoestellen
Hyacinthstraat 2
4255 HX Nieuwendijk

Certificate issued on the basis of the following requirements : Warenwetbesluit Attractie- en Speeltoestellen,
NEN-EN 1176-1:2008, NEN-EN 1176-2:2008

Test laboratory : None

Date and number of the laboratory report : None

Date of type-examination : 2 June 2009 - 15 June 2009

Annexes with this certificate : Report belonging to the type-examination certificate
nr.: 200116202

Additional remarks : None

Conclusion : The playground equipment meets the requirements of the above specified European standard(s) and "Warenwetbesluit Attractie- en Speeltoestellen" taking into account any additional remarks mentioned above.

Issued in Amsterdam
Date of issue : 16 June 2009



Ir. V.M.A. Barendregt
LIFTINSTITUUT B.V.
Senior Officer Certification
& Technology



Drs. B. Mulder
LIFTINSTITUUT B.V.
Director Certification &
Inspection International

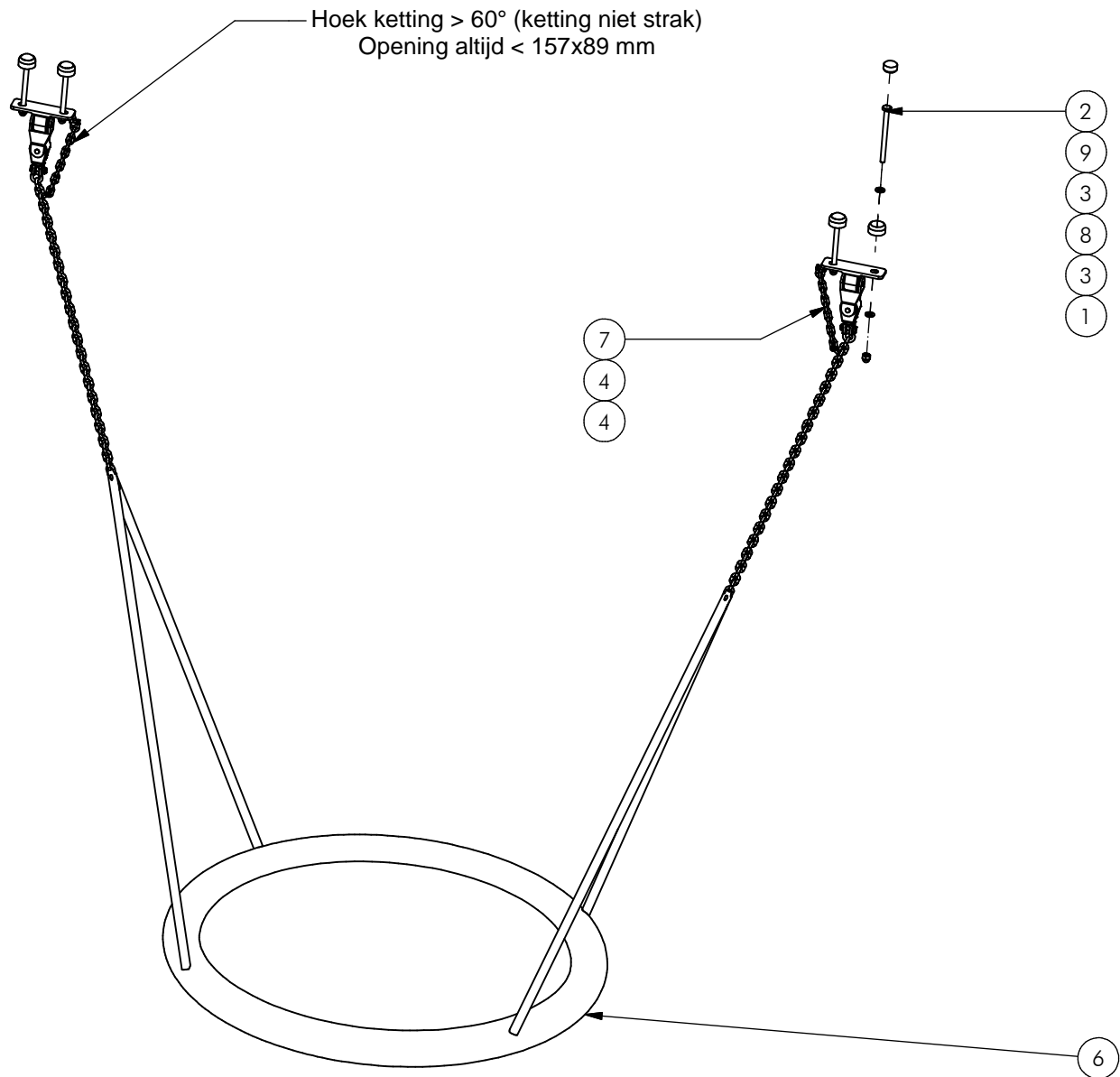

Nr	#	Type	Progr.	Volgnr	Bew.	Rev.	Benaming	Opmerking
1	4	BSR	011	010	020		DOPMOER	BORG RVS M10
2	4	BSR	021	010	130		Zeskantbout	M10 x 130 - RVS A2-70
3	8	BSR	030	010	002		SLUITRING	M10
4	4	BSR	031	005	000		D-Sluiting	5 mm, RVS A2-70
5	2	BSR	081	012	092		Scharnier dubbel NORMAAL	RVS A2-70
6	1	DRD	NST	001	100		Vogelnest Ø1,0 m	balk 2,5 m
7	2	KET	005	002	018		RVS ketting 5mm	0,18 m lang
8	4	KST	DON	010	060		Beschermkop M10-M12	Donut zwart
9	4	KST	DOP	010	060		Beschermkop M10-M12	Dop zwart

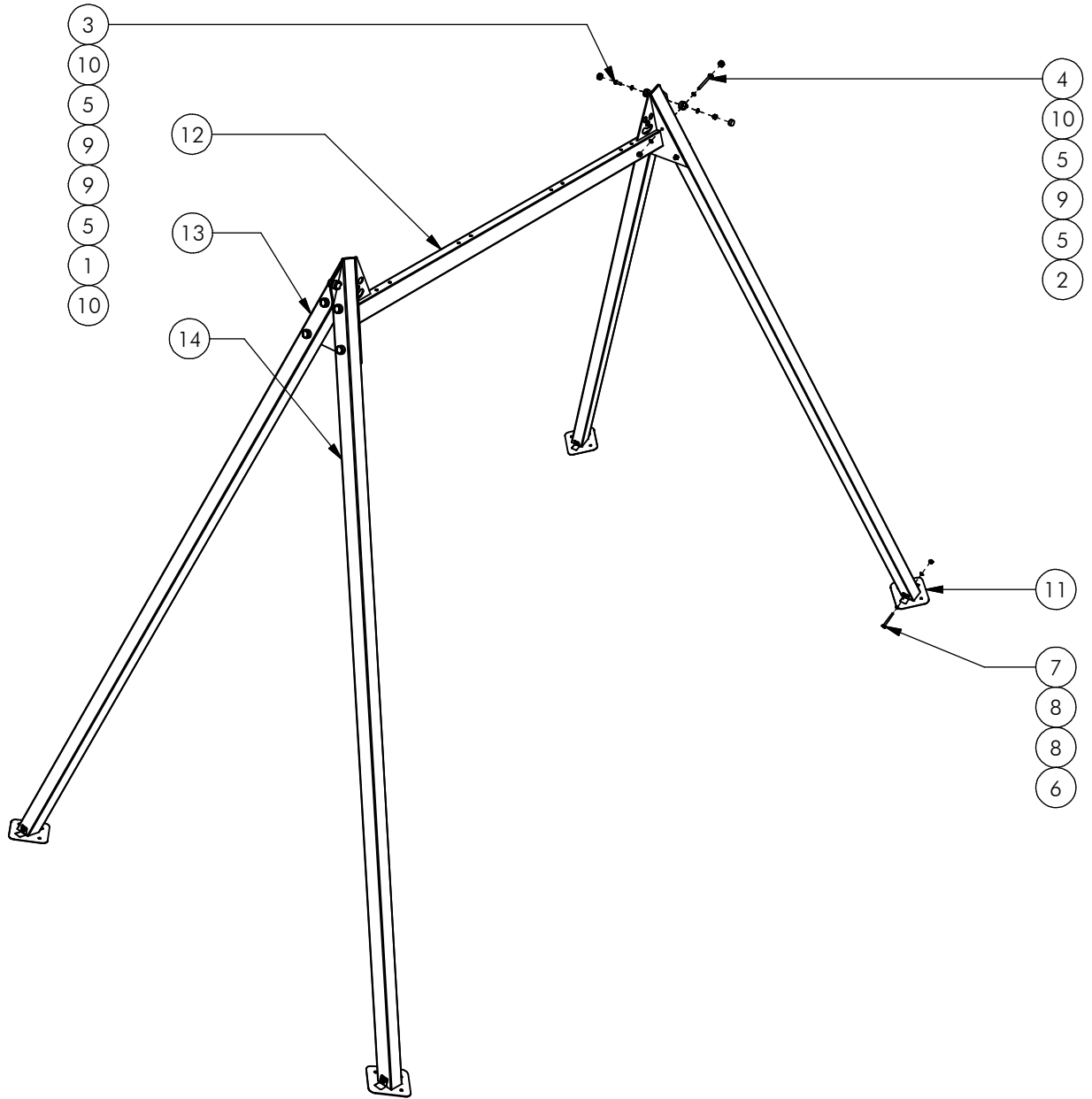

Nr.	#	Type	Progr.	Volgnr.	Bew.	Rev.	Benaming	Opmerking
1	2	BSR	010	010	010		Borgmoer	M10 - RVS A2-70
2	8	BSR	011	010	020		DOPMOER	BORG RVS M10
3	2	BSR	021	010	030		Zeskantbout	M10 x 30 - RVS A2-70
4	8	BSR	021	010	105		Zeskantbout	M10 x 105 - RVS A2-70
5	20	BSR	030	010	002		SLUITRING	M10
6	4	BSV	010	010	010		Borgmoer	M10 - VZ 8.8
7	4	BSV	021	010	100		Zeskantbout ISO 4014	M10 x 100 - VZ 8.8
8	8	BSV	030	010	002		SLUITRING	M10 VZ
9	12	KST	DON	010	030		Bescherm dop M10-M12	Donut Rood
10	12	KST	DOP	010	030		Bescherm dop M10-M12	Dop rood
11	4	OME	UKP	615	VZP	B	Voetplaat	Ukkepuk
12	1	SME	SOL	048	372	D	SCHOMMELBUIJS	DUBBEL ROOD
13	2	SME	SOL	050	372	D	Staander links	Schommel gecoat
14	2	SME	SOL	051	372	D	Staander rechts	Schommel gecoat



Benaming
Title Schommelframe

Opmerking
Comment Metal dubbel

Datum
Date 12-10-2017

Tekening
Drawing

MOD SOL 368 001 A
 Samenstelling module Assembly module