

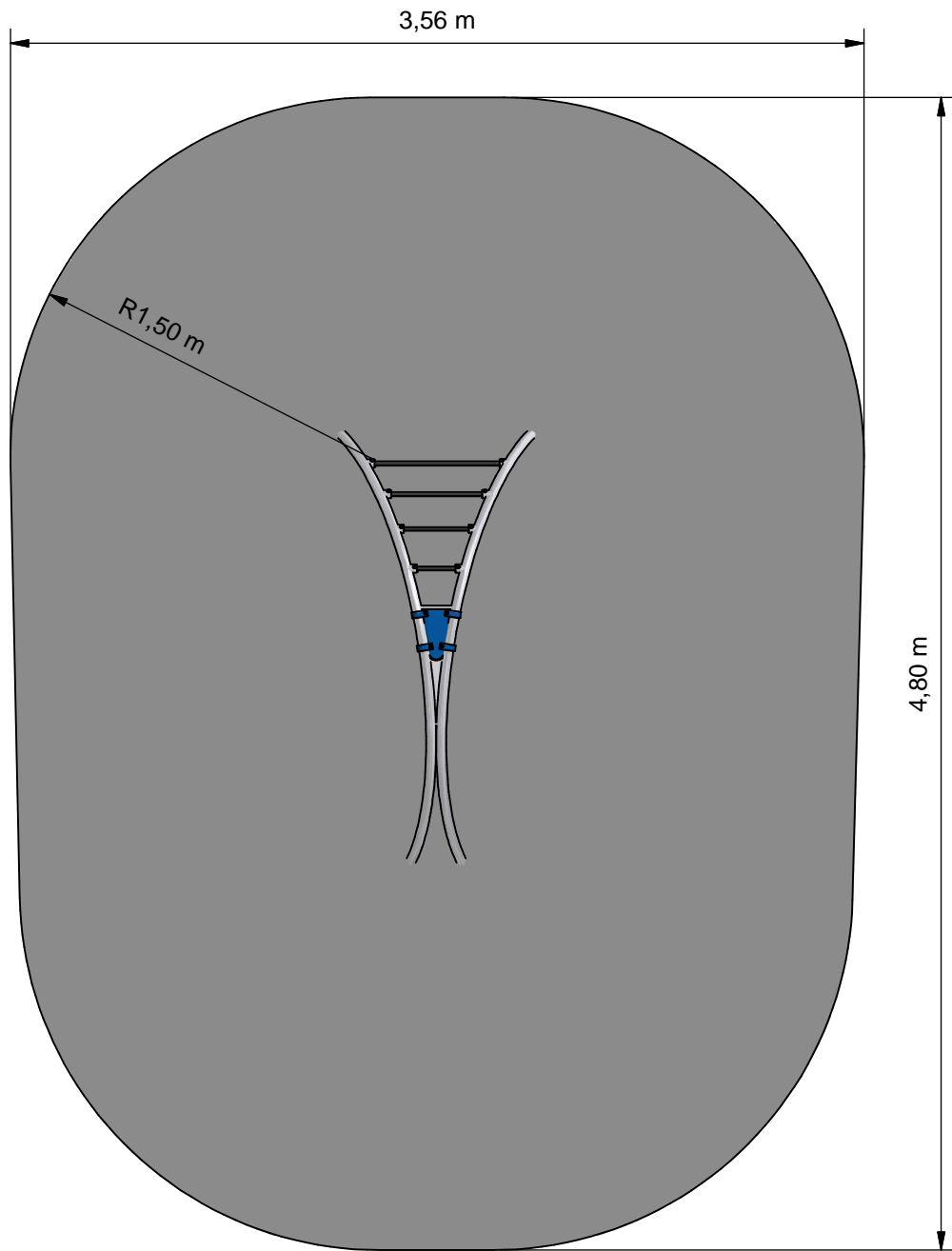

Little-Play X-Legs



LTPE381.703



- Opvangzone
Impact area
- Obstakelvrije zone
Obstacle free zone



Benaming / Title: X Legs
 Opmerking / Comment: Little Play
 Datum / Date: 1-12-2015

Tekening / Drawing

TOE LTP 381 703 A
 Obstakelvrije zone *Obstacle free zone*

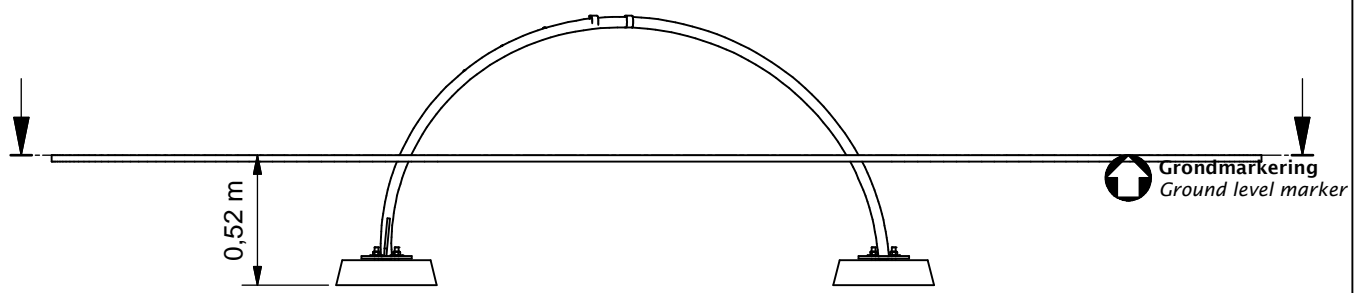
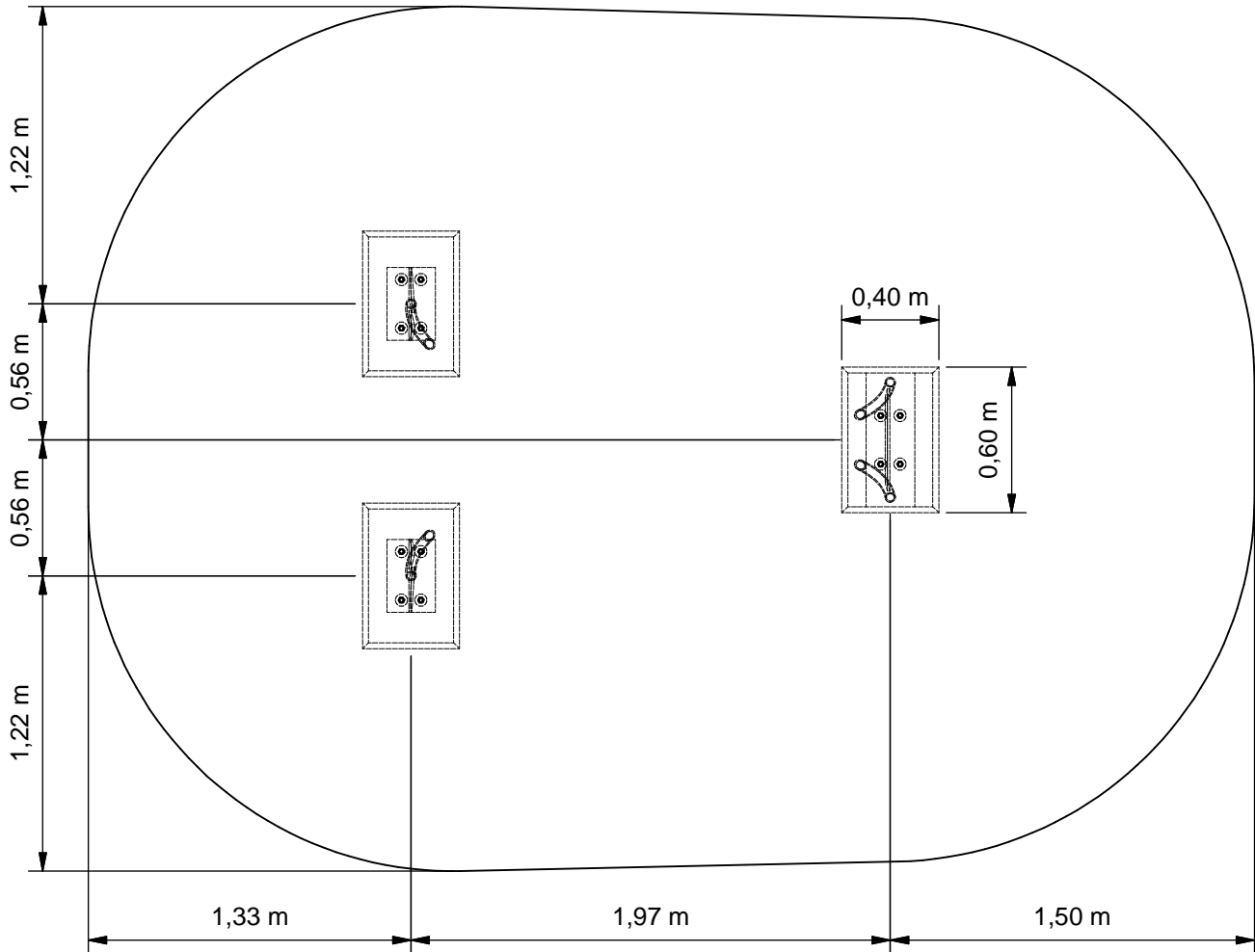

Benaming / Title: X Legs
 Opmerking / Comment: Little Play
 Datum / Date: 1-12-2015

Tekening / Drawing

TOE LTP 381 703 A

Bodemplan Groundplan

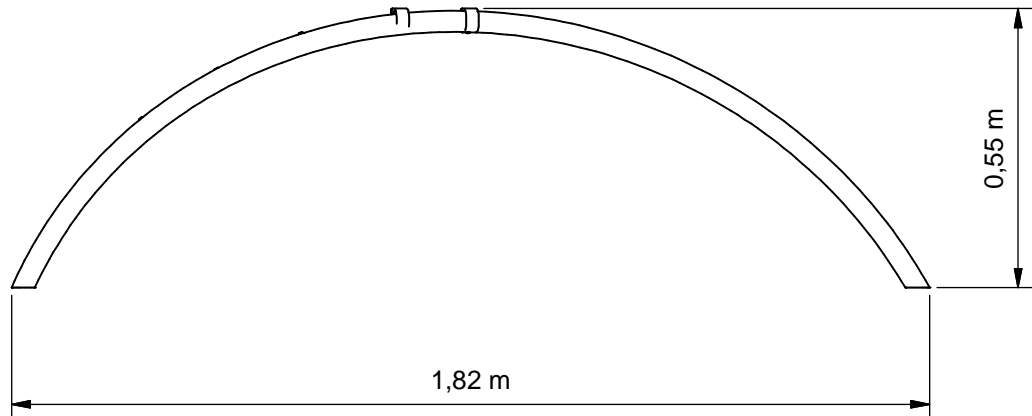
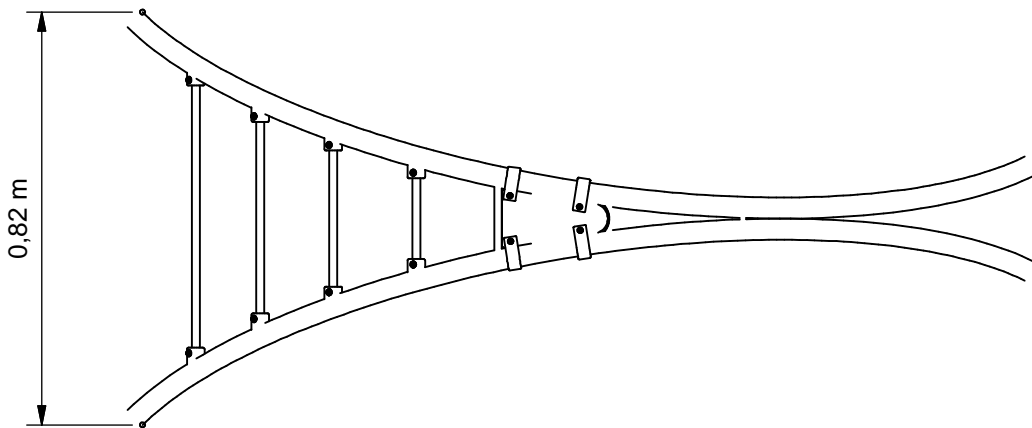

| | |
|----------------------|-------------|
| Benaming Title | X Legs |
| Opmerking Comment | Little Play |
| Datum Date | 1-12-2015 |

Tekening
Drawing

TOE LTP 381 703 A

Afmetingen Dimensions

Geleverde modules:

Zie tabel

Supplied modules:

See table

Montageinstructie:

- De hoofdmaten geven de maten van de staanders en vloeren aan
- De detailtekeningen geven specifiek de maten van de verbindingen aan
- De modules met buizen zijn op de tekeningen bemaat op bovenkant kopplaat
- Overige modules zijn bemaat op de bovenkant (klimwanden, paalkoppen, etc.)

Assembly instruction:

- The main dimensions indicate the dimensions of the posts and floors
- The detailed dimensions show the specific dimensions of the connections
- The modules which contain tubes are dimensioned at the top of the flanges
- Other modules are dimensioned at the top (climbing walls, caps for the posts, etc.)

Montagevolgorde:

- 1 - Graaf de gaten volgens het bodemplan
- 2 - Plaats 2(3x)
- 3 - Plaats 1 en verbind deze aan 2
- 4 - Controleer of het toestel voldoet aan de afmetingen zoals op blad 'afmetingen'
- 5 - Dicht de gaten en verdicht het zand

Assembly sequence:

- 1 - Dig the holes according to the ground plan
- 2 - Plaats 2(3x)
- 3 - Place 1 and attach it to 2
- 4 - Check that the equipment conforms to the dimensions shown on sheet 'dimensions'
- 5 - Close the holes and compact the sand

Controles:

- 1 - Correcte opbouw en alle bevestigingsmiddelen
- 2 - Controleer de afmetingen van de valbodem t.o.v. het toestel

Checks:

- 1 - Correct assembly and all the fasteners
- 2 - Check the dimensions of the safety area with regard to the play equipment

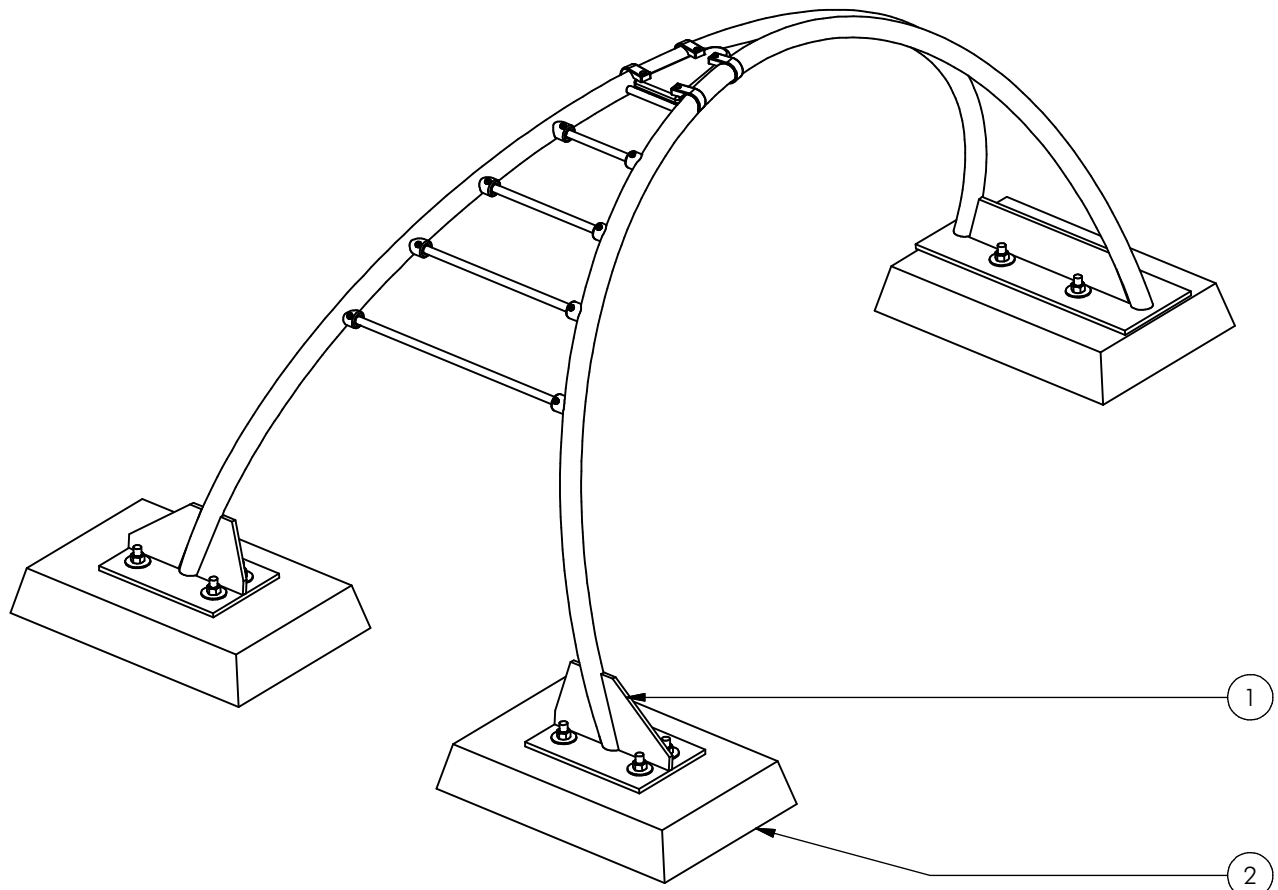

| Nr | # | Type | Progr. | Volgnr | Bew. | Rev. | Benaming | Opmerking |
|----|---|------|--------|--------|------|------|--------------|-------------|
| 1 | 1 | MOD | LTP | 703 | 001 | A | X Legs | Little Play |
| 2 | 3 | MOD | OBT | 010 | 001 | | Poermodel 10 | 50 kilo |



Benaming
Title X Legs

Opmerking
Comment Little Play

Datum
Date 1-12-2015

Tekening
Drawing

TOE LTP 381 703 A

Modules Modules

LTPE381.703

Little-Play X-Legs

LOGBOOK

(Onderstaand logboek kan gebruikt worden om te voldoen aan de eisen, gesteld in artikel 14 van het Warenwetbesluit Attractie- en Speeltoestellen)

| | |
|--|---|
| Type indication | Play triggers |
| Product code | LTPE381.703 |
| Name of equipment | Little-Play X-Legs |
| Maximum height of fall | < 0,6 m |
| Year of construction | 2017 |
| Certificate | 038055 |
| inspection authority | TUV Nederland QA BV De Waal 21c, Best - 5684 PH Best |
| Name manufacturer | BOERplay Hyacintstraat 2 - 4255 HX Nieuwendijk Phone: +31 (0)183 40 23 66 Fax: +31 (0)183 40 35 64 |
| name installer | _____ _____ |
| Description of equipment | Little-Play X-Legs |
| Location of equipment | _____ |
| Data about the owner of the play equipment | |
| Name: | _____ |
| Address: | _____ |
| Postcode and town: | _____ |
| Contact person: | _____ |
| Telephone number: | _____ |
| Data about the administrator of the play equipment | |
| Name: | _____ |
| Address: | _____ |
| Postcode and town: | _____ |
| Contact person: | _____ |
| Telephone number: | _____ |

LOGBOOK

Inspection and maintenance intervals



| Nr. | Inspection | Maintenance | months between inspections |
|-----|--|--|----------------------------|
| 1 | Verify equipment's stability, junctions and missing parts. Inspect bolts, screws and nuts for absence, jams, corrosion and wear. | Add missing parts, secure joints, apply missing fixing agent and replace corroded parts. | 1 |
| 2 | Check suspension for wear. | Replace worn parts and/or remove non-functioning parts. | 1 |
| 3 | Inspect rotating parts such as hinges, rolling-element bearings, etc. for wear and acceptability. | Replace worn parts and/or remove non-functioning parts. | 1 |
| 4 | Check wood for splinters, unacceptable damage and signs of rot. Especially at ground level. | Repair damage. Replace affected wood. Smoothen splintered wood and sharp edges. | 1 |
| 5 | Inspect foundation for stability, tearing and coverage. | Restore foundation and covering material. | 3 |
| 6 | Examine rubber and synthetic parts for wear, damage and break. | Replace original parts. | 3 |
| 7 | Inspect metal for corrosion and damage in the coating. | Restore any damaged coating (after removing rust and applying primer). | 6 |
| 8 | Check ropes, cables, chains and nets for wear and damage. Steel cables and nets which are tensioned must be checked for tension. | Replace parts where necessary. Steel cables and nets must be tensioned. | 3 |
| 9 | Inspect equipment for unsafe changes and additions. | Remove unsafe additions and correct unsafe changes. | 1 |
| 10 | Inspect safety surfaces. | Restore and repair where necessary. | 1 |

Remarks

1. If used intensively, all points require extra attention.
2. Extreme weather conditions and locations may require a higher inspection frequency. Discuss this with the supplier.
3. Vandalism-sensitive locations require stricter inspections, possibly daily.
4. Check the terrain regularly for items that do not belong there, are unsafe or may be used wrongly. Examples are poisonous plants, glass shards, etc. Frequency depends on strain.
5. Remember that bad maintenance leads to unsafe conditions and notably faster impoverishment of the playground area.
6. Replacement parts can be ordered at the manufacturer with the part numbers on the module drawing. Drawings can be found in de user guide.
7. The impact area shall be provided with impact attenuating surface according to the specified falling height.
8. This list is conform the CEN-standard "playground equipment and surfacing NEN-EN 1176-7".

Warenwet

Certificaat van Typeonderzoek Type Examination Certificate

afgegeven door issued by

TÜV Nederland QA BV



aangewezen bij ministeriële beschikking van
4 mei 2012, nr. VGP 3113590

commissioned by departmental order
of 4 May 2012, no. VGP 3113590

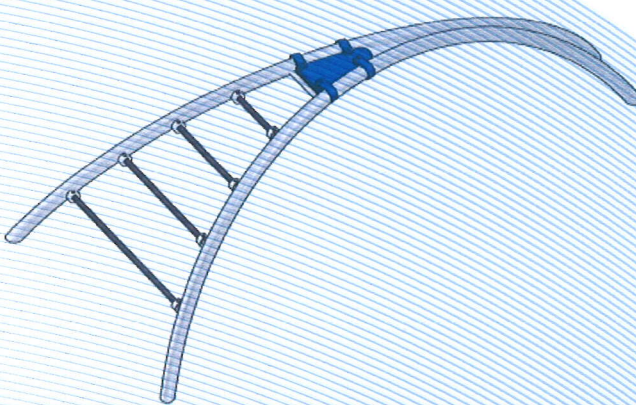
| | | | |
|--|---|--|----------|
| Certificaat nr. Certificate nr. | 038055TA_20140912 | Dossiernr. File nr. | 038055TA |
| Productomschrijving Product description | X-Legs | | |
| Evt. nadere aanduidingen Further indications | | | |
| voor nadere informatie zie bijbehorend rapport met gelijkloidend dossiernr. for further information see associated report with identical file nr. |  | | |
| Eigenaar / certificaathouder en adres Owner/certificate holder and address | Boer Speeltoestellen B.V. Hyacintstraat 2 4255HX NIEUWENDIJK | | |
| Soort toestel Category of equipment | Speeltoestel / Playground equipment | | |
| Fabrikant Manufacturer | Boer Speeltoestellen B.V. Hyacintstraat 2 4255HX NIEUWENDIJK | | |
| Type/Serienummer Type/Serial number | LTP-381703 / | in te vullen door de fabrikant to be filled out by the manufacturer | |
| Jaar van fabricage Year of construction | vanaf 2014 since | | |
| Leverancier Supplier | Boer Speeltoestellen B.V. Hyacintstraat 2 4255HX NIEUWENDIJK | | |
| Jaar van leverantie Year of supply | in te vullen door de leverancier to be filled out by the supplier | | |
| Datum keuring Date of examination | 17-01-2014 - 12-09-2014 | | |

TÜV Nederland QA BV, de Waal 21C, NL-5684 PH Best verklaart, dat het bovenaangehaalde toestel voldoet aan de vervaardigingvoorschriften genoemd in het Warenwetbesluit attractie- en speeltoestellen (met als leidraad de normatieve documenten NEN-EN 1176:2008).

TÜV Nederland QA BV declares that the here above mentioned equipment meets the safety and health requirements mentioned in the Dutch law "Warenwetbesluit attractie- en speeltoestellen" (guided by normative documents EN 1176:2008).

| | |
|---|--|
| Namens het bestuur, For the board, A.C. Boon Directeur |  |
|---|--|

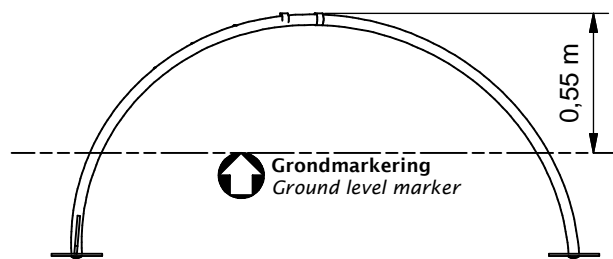
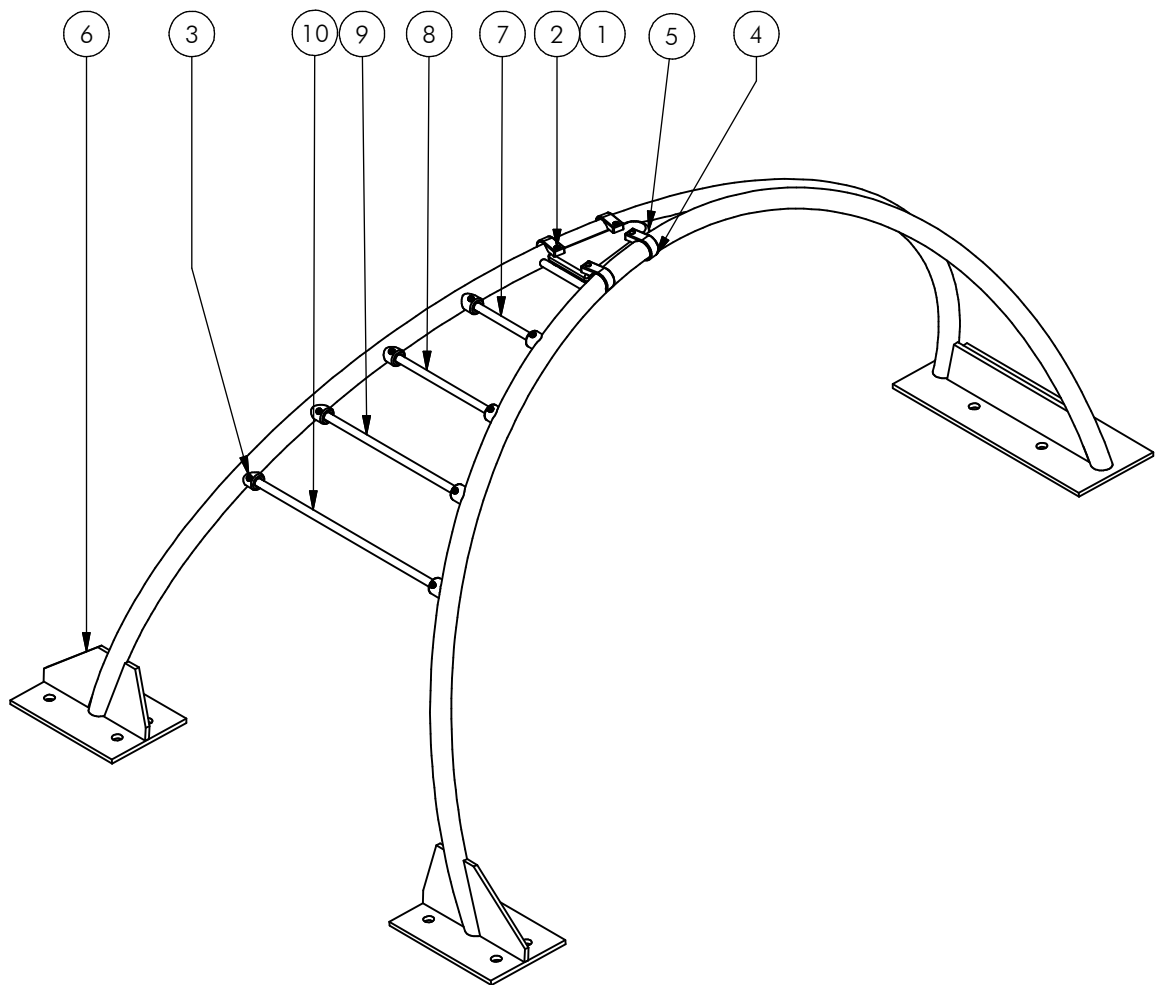

| Nr | # | Type | Progr. | Volgnr | Bew. | Rev. | Benaming | Opmerking |
|----|---|------|--------|--------|------|------|-----------------------|---------------------|
| 1 | 4 | BSR | 011 | 006 | 012 | | Borgdopmoer | M6 - RVS A2-70 |
| 2 | 4 | BSV | 023 | 006 | 040 | | Bolkopbout ISO 7380 | M6 x 40 - RVS A2-70 |
| 3 | 8 | BSV | 025 | 006 | 030 | | Veiligheidsschroef | Pin-Torx - VZ 8.8 |
| 4 | 4 | KST | KLM | 042 | 050 | | Klembeugel blauw 42mm | 800095001065 |
| 5 | 1 | OPE | LTP | 001 | 050 | | Afdekplaat | X Legs |
| 6 | 1 | SME | LTP | 009 | 906 | A | X Legs | Little Play |
| 7 | 1 | SNT | LTP | 012 | 090 | | Hercules Touw | 16 mm Zwart L=210 |
| 8 | 1 | SNT | LTP | 013 | 090 | | Hercules Touw | 16 mm Zwart L=320 |
| 9 | 1 | SNT | LTP | 014 | 090 | | Hercules Touw | 16 mm Zwart L=430 |
| 10 | 1 | SNT | LTP | 015 | 090 | | Hercules Touw | 16 mm Zwart L=570 |



Benaming Title X Legs
 Opmerking Comment Little Play
 Datum Date 15-1-2016

Tekening Drawing

MOD LTP 703 001 A
 Samenstelling module Assembly module

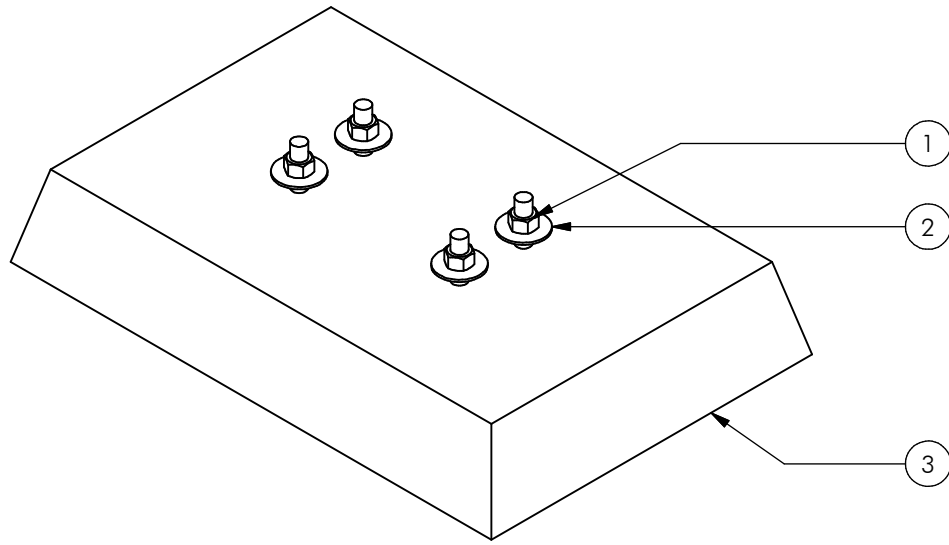

| Nr | # | Type | Progr. | Volgnr | Bew. | Rev. | Benaming | Opmerking |
|----|---|------|--------|--------|------|------|-----------------|-------------------|
| 1 | 4 | BSV | 017 | 016 | 015 | | Zeskantmoer | M16 - VZ 8.8 |
| 2 | 4 | BSV | 035 | 016 | 050 | | Carrosseriering | M16 x 50 - VZ 8.8 |
| 3 | 1 | OBT | POE | 010 | 050 | | Poermodel 10 | 50 kg |



Benaming
Title Poermodel 10

Opmerking
Comment 50 kilo

Datum
Date 27-8-2015

Tekening
Drawing

MOD OBT 010 001

Samenstelling module Assembly module