

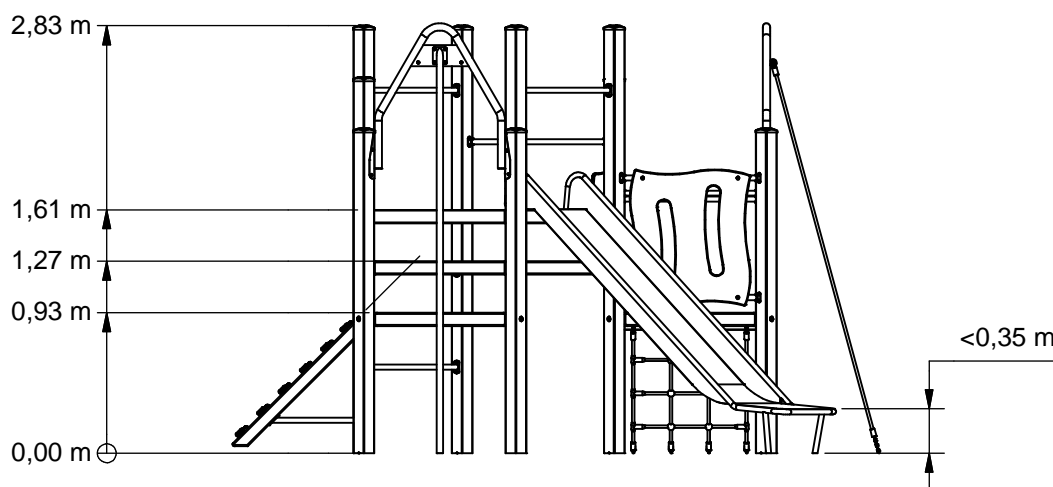

Combination equipment

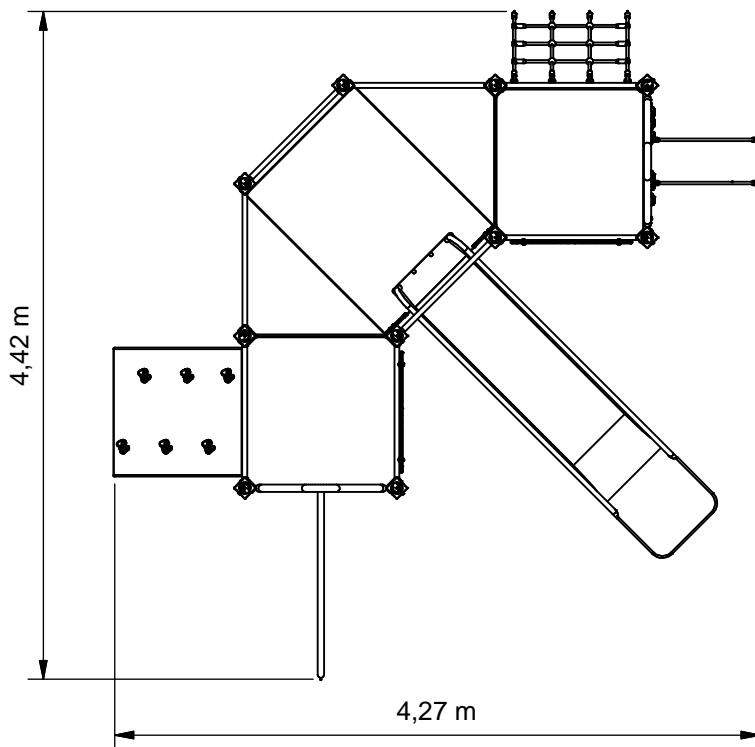

VRBE080.783



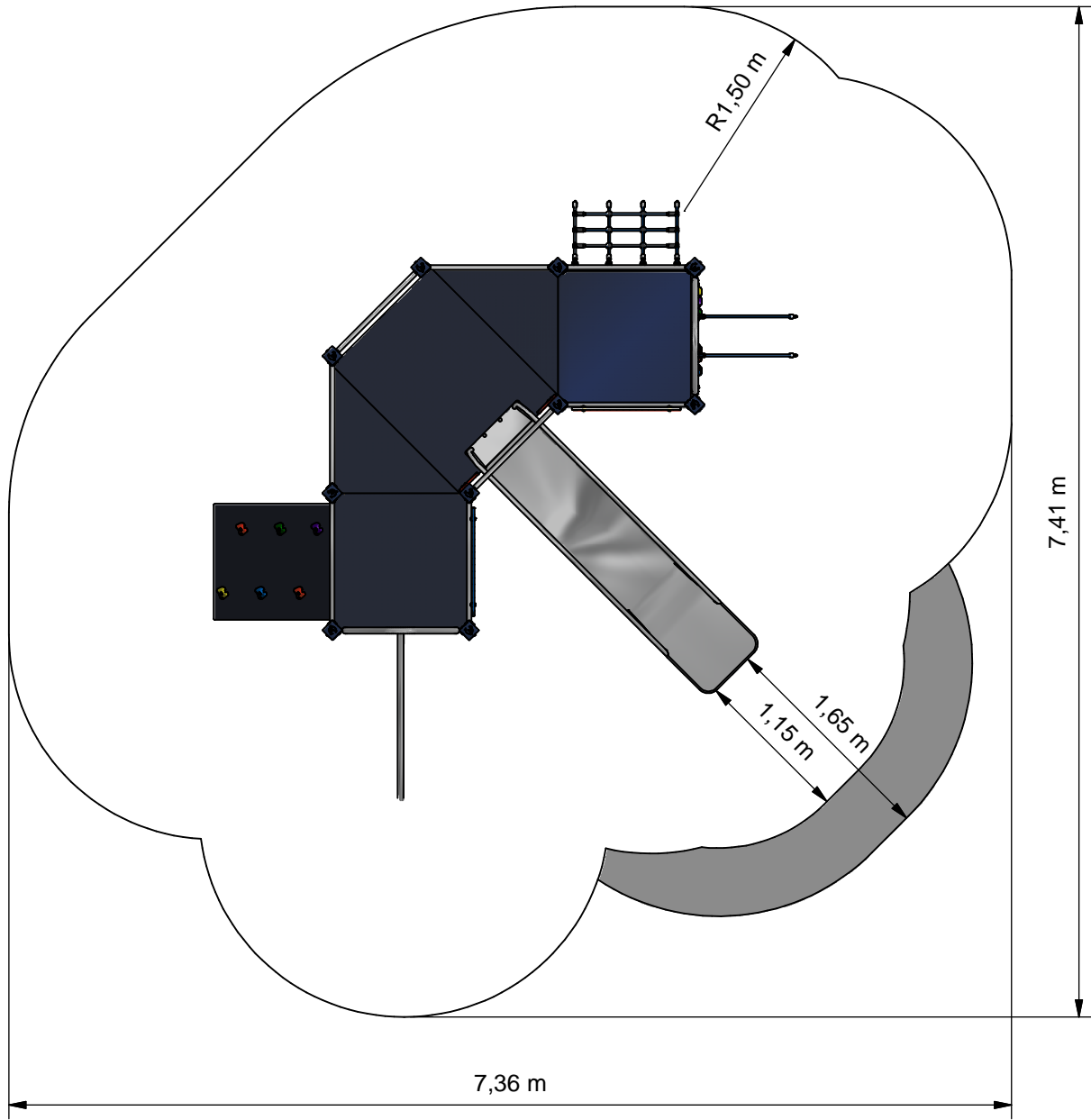

- Opvangzone
Impact area
- Obstakelvrije zone
Obstacle free zone



Benaming / Title: Vrijbuiters
 Opmerking / Comment: Hardhout
 Datum / Date: 18-2-2014

Tekening / Drawing

TOE VRB 080 783 C
 Obstakelvrije zone *Obstacle free zone*

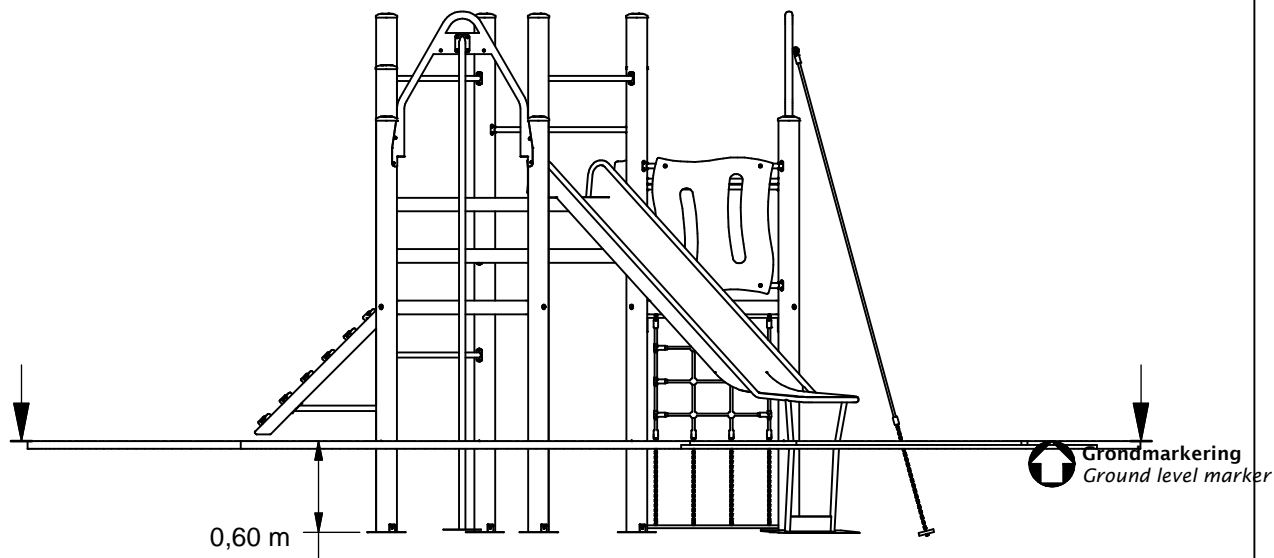
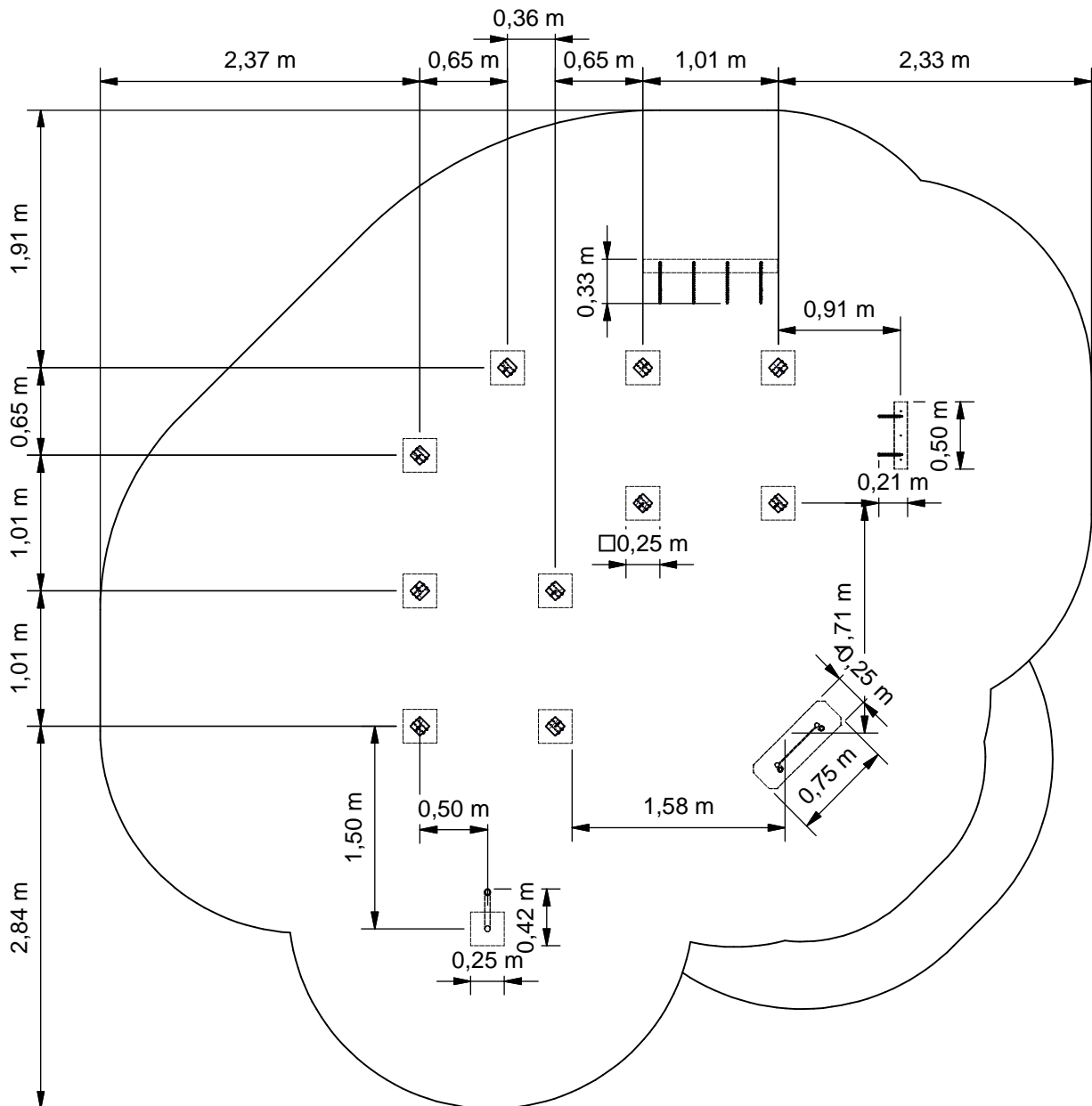

Benaming
Title Vrijbuiters

Opmerking
Comment Hardhout

Datum
Date 18-2-2014

Tekening
Drawing

TOE VRB 080 783 C

Bodemplan Groundplan

Geleverde modules:

Zie tabel

Supplied modules:

See table

Montageinstructie:

- De hoofdmaten geven de maten van de staanders en vloeren aan
- De detailtekeningen geven specifiek de maten van de verbindingen aan
- De modules met buizen zijn op de tekeningen bemaat op bovenkant kopplaat
- Overige modules zijn bemaat op de bovenkant (klimwanden, paalkoppen, etc.)

Assembly instruction:

- The main dimensions indicate the dimensions of the posts and floors
- The detailed dimensions show the specific dimensions of the connections
- The modules which contain tubes are dimensioned at the top of the flanges
- Other modules are dimensioned at the top (climbing walls, caps for the posts, etc.)

Montagevolgorde:

- 1 - Graaf de gaten volgens het bodemplan
- 2 - Assembleer toren met 11(4x),16,1(5x)
- 3 - Plaats toren
- 4 - Plaats 14,15 en verbind deze aan 16
- 5 - Plaats 3,10,13 en verbind deze aan de toren
- 6 - Plaats 9(2x),2,4 en verbind deze aan 10,11
- 7 - Plaats 6,8 en verbind deze aan 2
- 8 - Plaats 3,10,13 en verbind deze aan de andere kant van de toren
- 9 - Plaats 9(2x),2,12,13 en verbind deze aan 10,11
- 10 - Plaats 5,7 en verbind deze aan 2
- 11 - Controleer of het toestel voldoet aan de afmetingen zoals op blad 'afmetingen'
- 12 - Dicht de gaten en verdicht het zand

Installation sequence:

- 1 - Dig the holes according to the ground plan
- 2 - Assemble tower 11 (4x), 16,1 (5x)
- 3 - Place tower
- 4 - Place 14,15 and attach it to 16
- 5 - Place 3,10,13 and attach it to the tower
- 6 - Place 9 (2x),2,4 and attach it to 10,11
- 7 - Place 6,8 and attach it to two
- 8 - Place 3,10,13 and attach it to the other side of the tower
- 9 - Position 9 (2x), 2,12,13 and attach it to 10,11
- 10 - Place 5,7 and attach it to 2
- 11 - Check that the unit conforms to the dimensions on sheet 'dimensions'
- 12 - Close the holes and compacted the sand

Controles:

- 1 - Correcte opbouw en alle bevestigingsmiddelen
- 2 - Controleer de afmetingen van de valbodem t.o.v. het toestel

Checks:

- 1 - Correct assembly and all the fasteners
- 2 - Check the dimensions of the safety area with regard to the play equipment

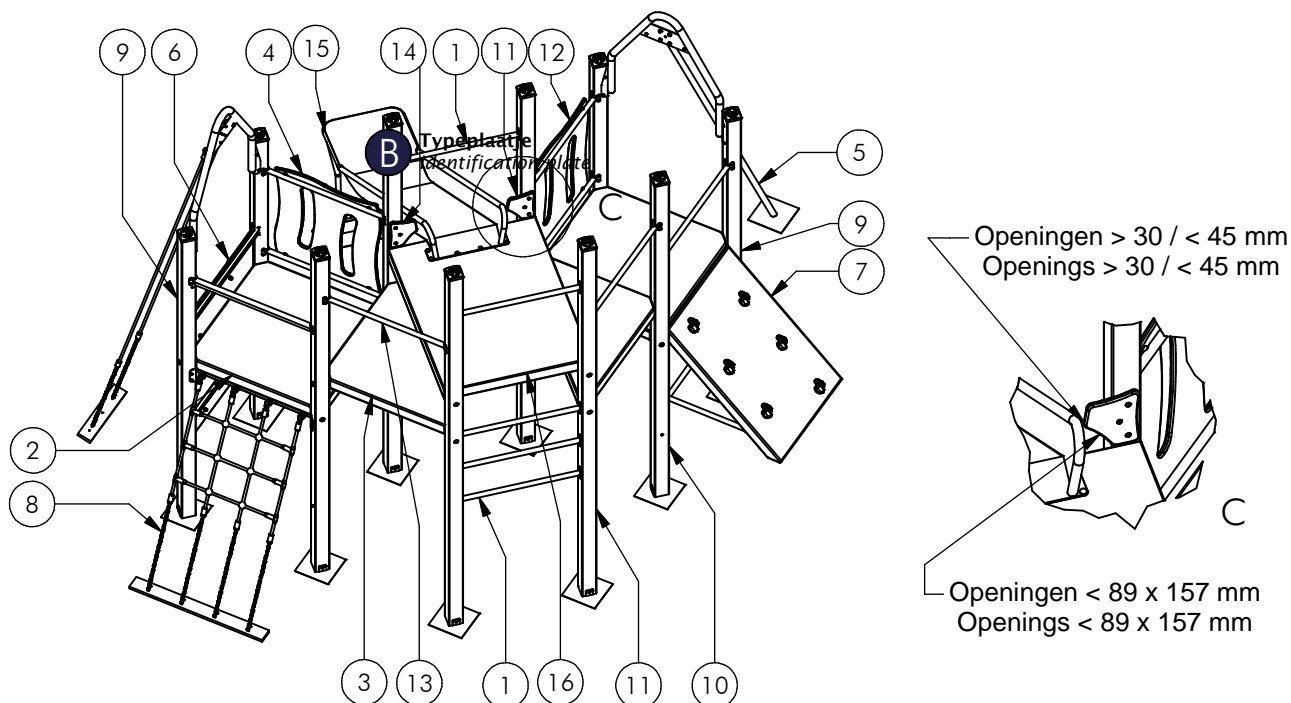

Nr	#	Type	Progr.	Volgnr	Bew.	Rev.	Benaming	Opmerking
1	5	MOD	VRB	HHT	656		Systeembuis	820 mm
2	2	MOD	VRB	HHT	008		VIERKANTVLOER	VRIJBUIER
3	2	MOD	VRB	HHT	009		DRIEHOEKVLOER	VRIJBUIER
4	1	MOD	VRB	HHT	011	A	WANDJE SLEUF	ROOD
5	1	MOD	VRB	HHT	022		GLIJPAAL	VLOER 93 CM
6	1	MOD	VRB	HHT	026	B	Klimwand 93 cm (S4)	Touwen aan beugel
7	1	MOD	VRB	HHT	027		OPLOOP	VRB
8	1	MOD	VRB	HHT	031	A	Oploopnet	Vloer S4
9	4	MOD	VRB	HHT	052		STAANDER	213 CM
10	2	MOD	VRB	HHT	054		STAANDER	247 CM
11	4	MOD	VRB	HHT	055		STAANDER	281 CM
12	1	MOD	VRB	HHT	059	A	WANDJE SLEUF	BLAUW
13	3	MOD	VRB	HHT	075		SYSTEEMBUIS	ENKEL
14	1	MOD	VRB	HHT	189	A	Valbeveiliging	Rechthoekvloer
15	1	MOD	VRB	HHT	192		Glijbaan 161 cm	Module HHT
16	1	MOD	VRB	HHT	194		Koppelvloer	Diagonaal



Benaming
Title: Vrijbuitter

Opmerking
Comment: Hardhout

Datum
Date: 18-2-2014

Tekening
Drawing

TOE VRB 080 783 C

Modules Modules

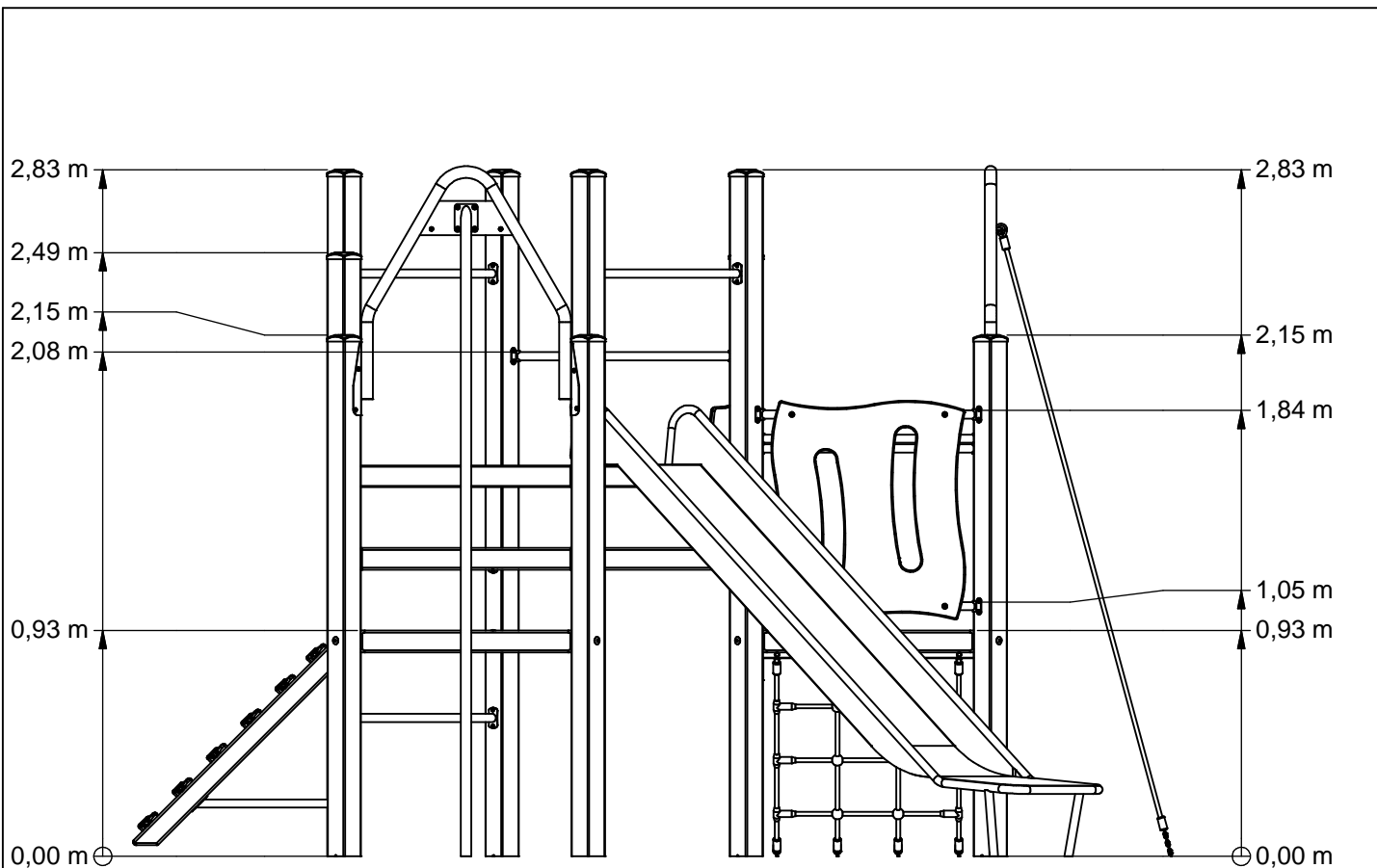

Voor
(Front)

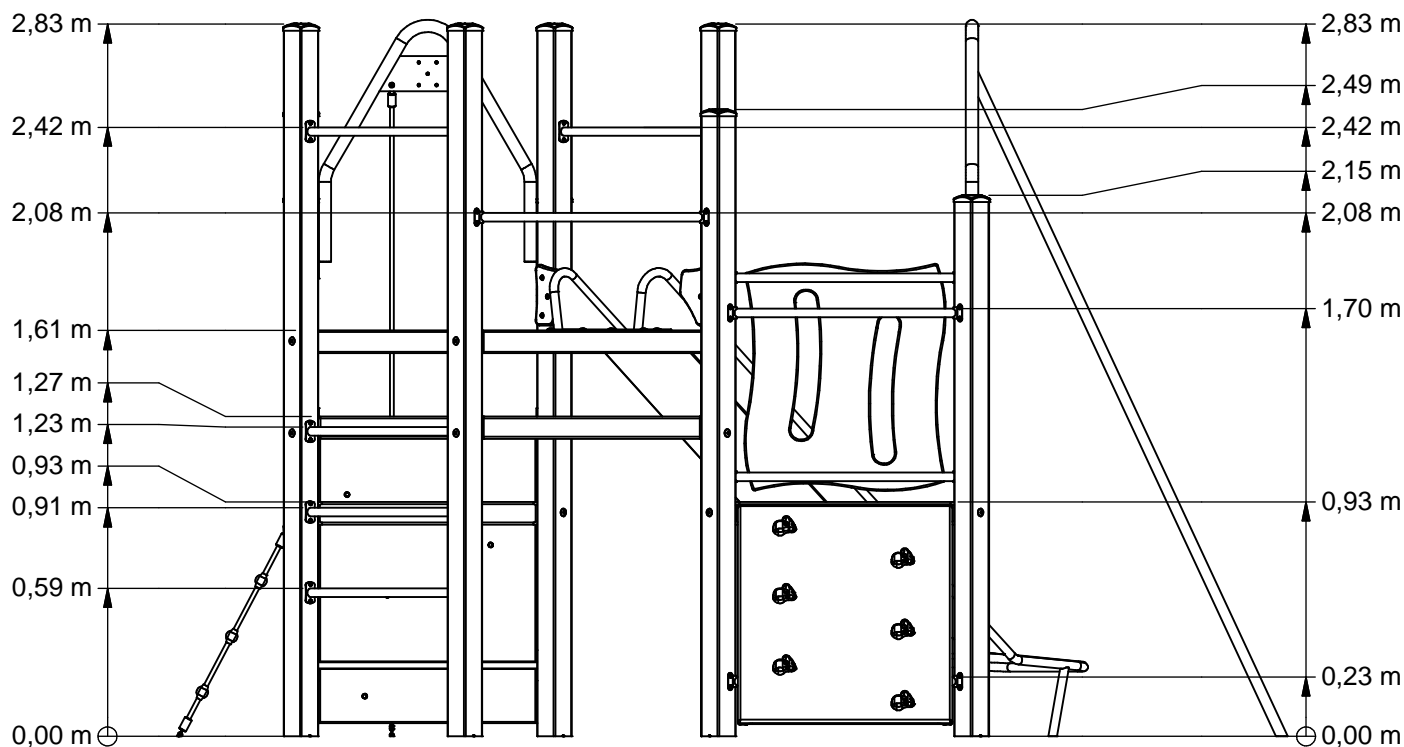

Links
(Left)



Benaming
Title Vrijbuiter

Opmerking
Comment Hardhout

Datum
Date 18-2-2014

Tekening
Drawing

TOE VRB 080 783 C

Afmetingen Dimensions

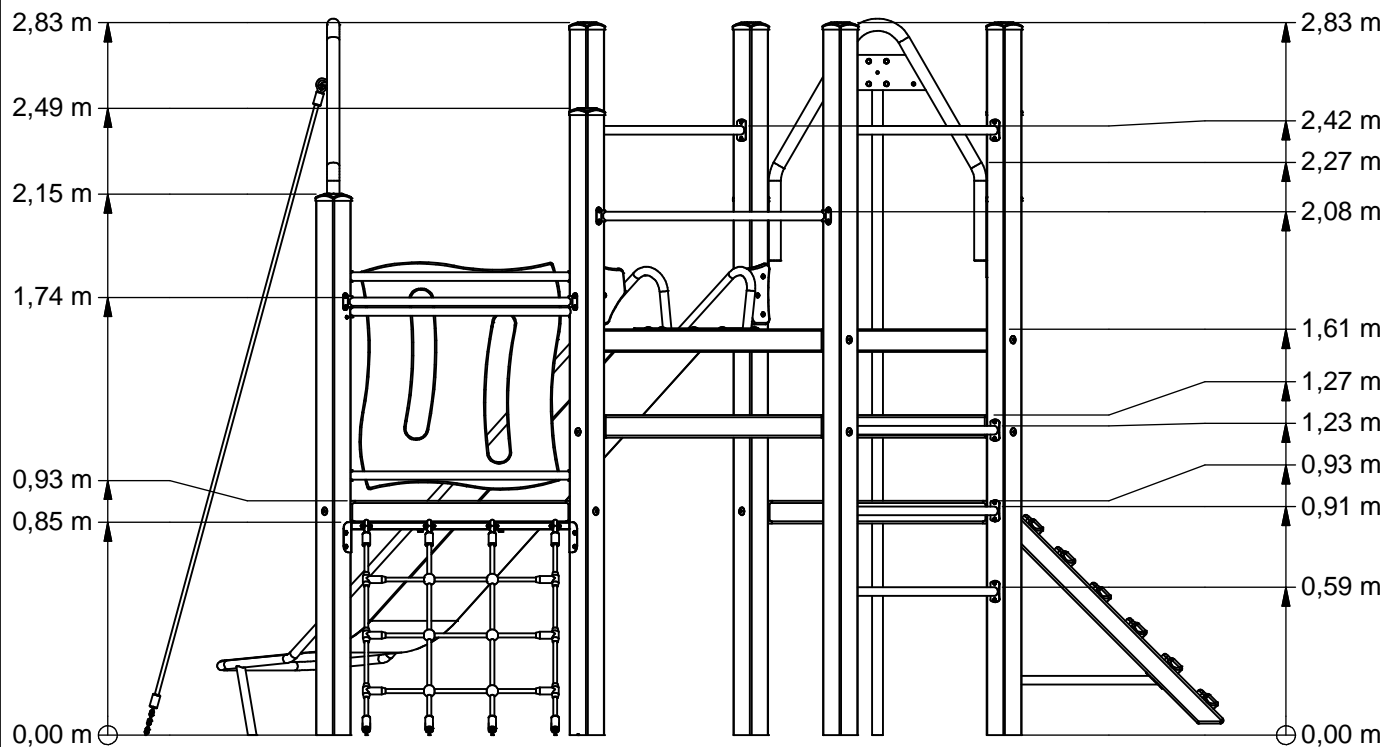

Achter
(Back)

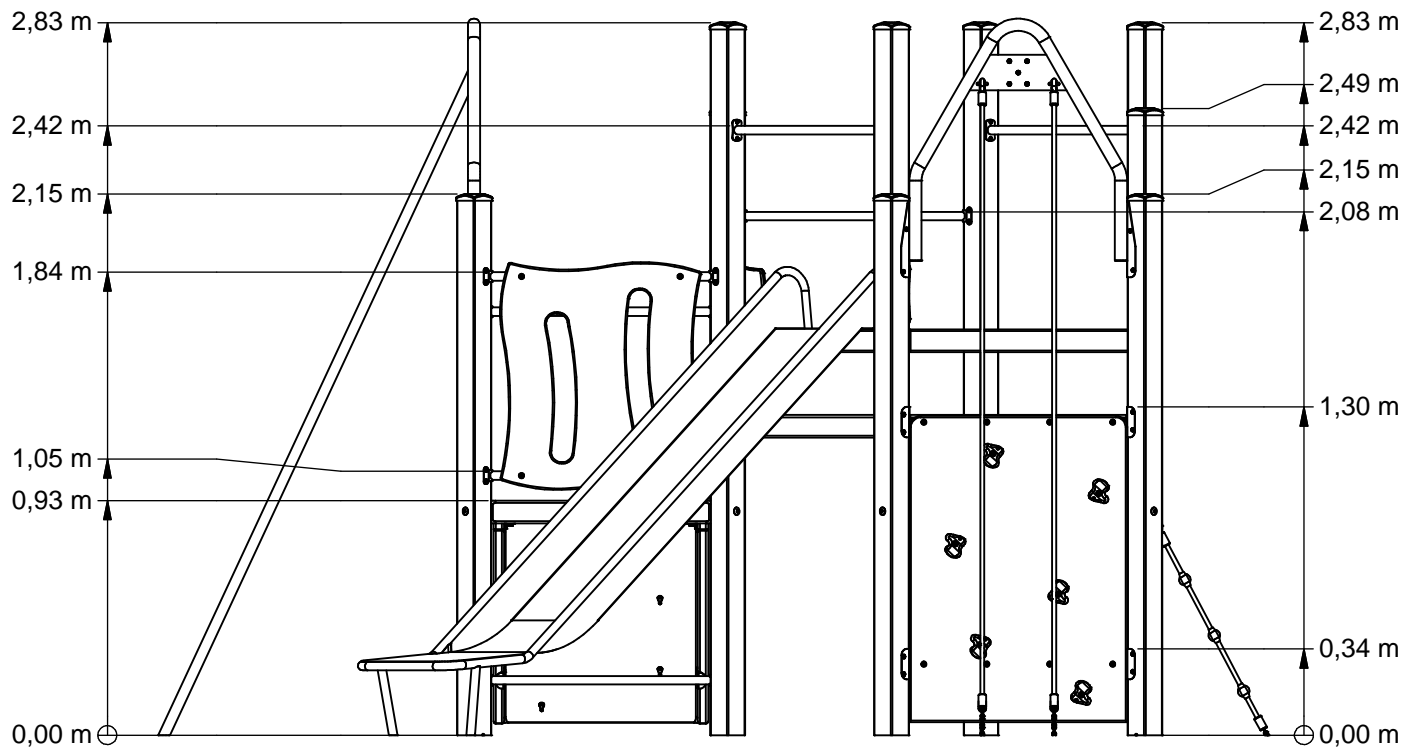

Rechts
(Right)



Benaming
Title Vrijbuiters

Opmerking
Comment Hardhout

Datum
Date 18-2-2014

Tekening
Drawing

TOE VRB 080 783 C

Afmetingen Dimensions

VRBE080.783

Combination equipment

LOGBOOK

(Onderstaand logboek kan gebruikt worden om te voldoen aan de eisen, gesteld in artikel 14 van het Warenwetbesluit Attractie- en Speeltoestellen)

Type indication	Nature Play
Product code	VRBE080.783
Name of equipment	Vrijbuitter Klimklautertoestel
Maximum height of fall	1,6 m
Year of construction	2017
Certificate	09200116201
inspection authority	Liftinstituut B.V. Buikslotermeerplein 381, A'dam - 1025 XE Amsterdam
Name manufacturer	BOERplay Hyacintstraat 2 - 4255 HX Nieuwendijk Phone: +31 (0)183 40 23 66 Fax: +31 (0)183 40 35 64
name installer	_____ _____
Description of equipment	Combination equipment
Location of equipment	_____
Data about the owner of the play equipment	
Name:	_____
Address:	_____
Postcode and town:	_____
Contact person:	_____
Telephone number:	_____
Data about the administrator of the play equipment	
Name:	_____
Address:	_____
Postcode and town:	_____
Contact person:	_____
Telephone number:	_____

LOGBOOK

Inspection and maintenance intervals



Nr.	Inspection	Maintenance	months between inspections
1	Verify equipment's stability, junctions and missing parts. Inspect bolts, screws and nuts for absence, jams, corrosion and wear.	Add missing parts, secure joints, apply missing fixing agent and replace corroded parts.	1
2	Check suspension for wear.	Replace worn parts and/or remove non-functioning parts.	1
3	Inspect rotating parts such as hinges, rolling-element bearings, etc. for wear and acceptability.	Replace worn parts and/or remove non-functioning parts.	1
4	Check wood for splinters, unacceptable damage and signs of rot. Especially at ground level.	Repair damage. Replace affected wood. Smoothen splintered wood and sharp edges.	1
5	Inspect foundation for stability, tearing and coverage.	Restore foundation and covering material.	3
6	Examine rubber and synthetic parts for wear, damage and break.	Replace original parts.	3
7	Inspect metal for corrosion and damage in the coating.	Restore any damaged coating (after removing rust and applying primer).	6
8	Check ropes, cables, chains and nets for wear and damage. Steel cables and nets which are tensioned must be checked for tension.	Replace parts where necessary. Steel cables and nets must be tensioned.	3
9	Inspect equipment for unsafe changes and additions.	Remove unsafe additions and correct unsafe changes.	1
10	Inspect safety surfaces.	Restore and repair where necessary.	1

Remarks

1. If used intensively, all points require extra attention.
2. Extreme weather conditions and locations may require a higher inspection frequency. Discuss this with the supplier.
3. Vandalism-sensitive locations require stricter inspections, possibly daily.
4. Check the terrain regularly for items that do not belong there, are unsafe or may be used wrongly. Examples are poisonous plants, glass shards, etc. Frequency depends on strain.
5. Remember that bad maintenance leads to unsafe conditions and notably faster impoverishment of the playground area.
6. Replacement parts can be ordered at the manufacturer with the part numbers on the module drawing. Drawings can be found in de user guide.
7. The impact area shall be provided with impact attenuating surface according to the specified falling height.
8. This list is conform the CEN-standard "playground equipment and surfacing NEN-EN 1176-7".

TYPE-EXAMINATION CERTIFICATE

Acting under the "Warenwetbesluit Attractie- en Speeltoestellen" issued by Liftinstituut B.V.
commissioned by departmental order, no. VGP/PSL 2857566 from 27 Juni 2008.

Certificate nr. : NL 09-2001-162-01 Revision nr.: 200116201

Description of the product : Playground equipment, made up by modules

Trademark, type : Speelwijzer, MOD VRB: 001 t/m 019, 021 t/m 027, 029, 031,032, 034 t/m 062, 065, 066, 071 t/m 074, 076, 077, 079 t/m 082, 190 t/m 193

Name and address of the manufacturer : Speelwijzer
Nijverheidsstraat 8
5317 NL Nederhemert Noord

Name and address of the certificate holder : Speelwijzer
Nijverheidsstraat 8
5317 NL Nederhemert Noord

Certificate issued on the basis of the following requirements : Warenwetbesluit Attractie- en Speeltoestellen

Test laboratory : None

Date and number of the laboratory report : None

Date of type-examination : September 3th 2001, February 9th 2009

Annexes with this certificate : Report belonging to the type-examination certificate nr.: NL 09-2001-162-01

Additional remarks : This certificate supersedes type certificate dated June 21th 2002, with certificate number NL 01-2001-162-01

Conclusion : The playground equipment meets the requirements of the above specified European standard(s) and "Warenwetbesluit Attractie- en Speeltoestellen" taking into account any additional remarks mentioned above.



Issued in Amsterdam

Date of issue : April 7th, 2009

Ir. V.M.A. Barendregt
Senior Officer Certification &
Technology
Liftinstituut B.V.

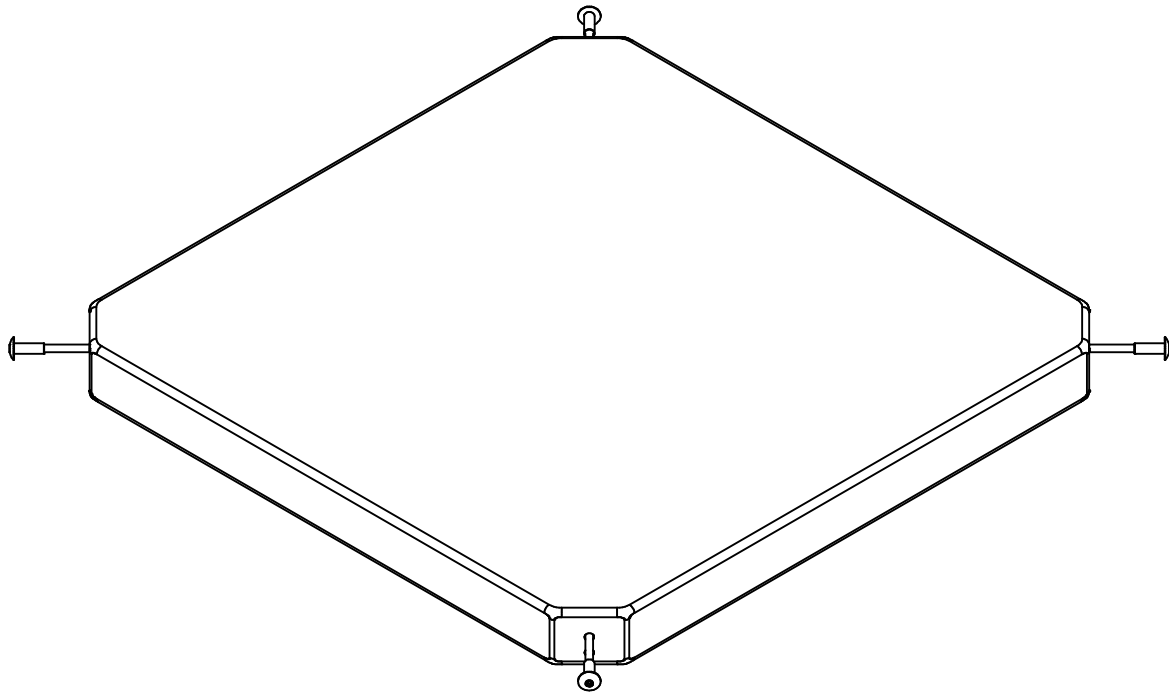

Nr	#	Type	Progr.	Volgnr	Bew.	Rev.	Benaming	Opmerking
1	4	BSR	021	010	110		Zeskantbout	M10 x 110 - RVS A2-70
2	4	BSR	035	010	030		CARROSSERIERING	M10 x 30 x 2,5
3	4	KST	LAM	015	005		LAMELLENSTOP	ROND 15
4	4	RNT	BUS	M10	040		DRAADBUS	M10 x 40
5	1	SHO	VRB	001	COA	C	Vloer VRB	Vierkant



Benaming
Title: VIERKANTVLOER

Opmerking
Comment: VRIJBUITER

Datum
Date: 10-1-2008

Tekening
Drawing

MOD VRB HHT 008

Samenstelling module Assembly module

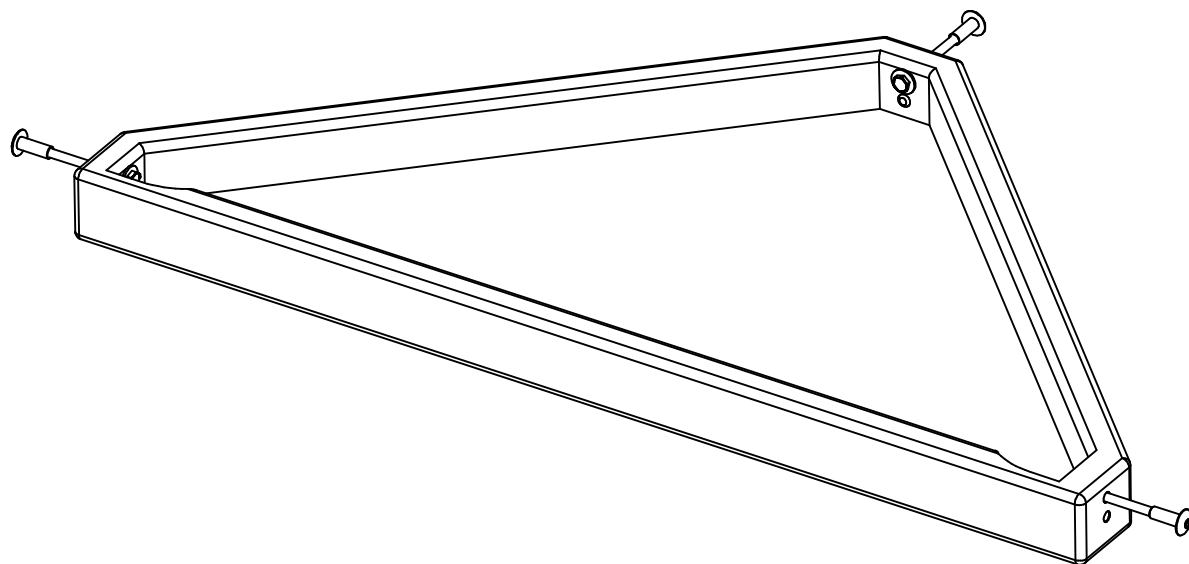

Nr	#	Type	Progr.	Volgnr	Bew.	Rev.	Benaming	Opmerking
1	3	BSR	021	010	110		Zeskantbout	M10 x 110 - RVS A2-70
2	3	BSR	035	010	030		CARROSSERIERING	M10 x 30 x 2,5
3	3	KST	LAM	015	005		LAMELLENSTOP	ROND 15
4	3	RNT	BUS	M10	040		DRAADBUS	M10 x 40
5	1	SHO	VRB	002	COA	B	VLOER VRB	DRIEHOEK



Benaming
Title DRIEHOEKVLOER

Opmerking
Comment VRIJBUITER

Datum
Date 10-1-2008

Tekening
Drawing

MOD VRB HHT 009

Samenstelling module *Assembly module*

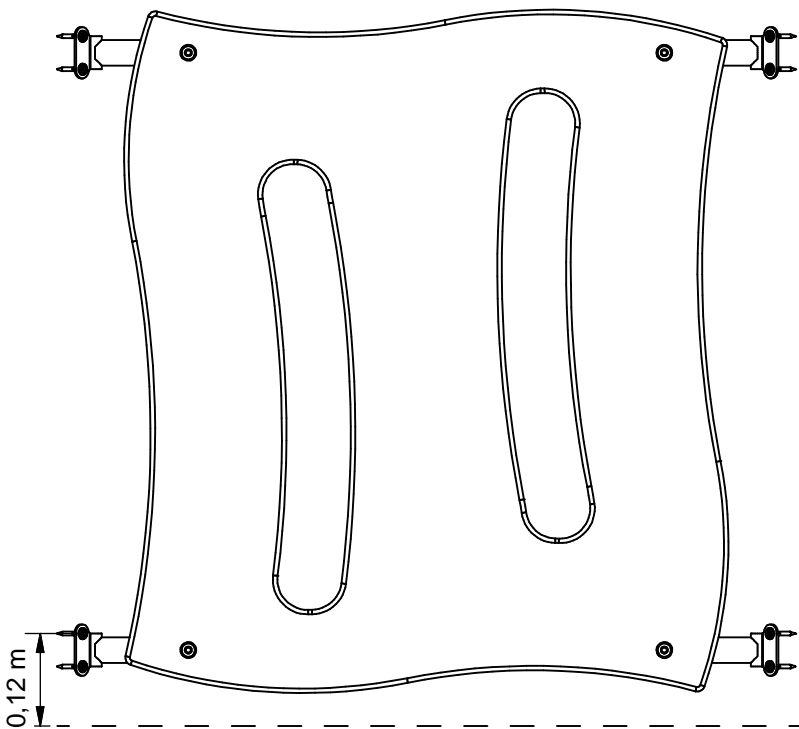
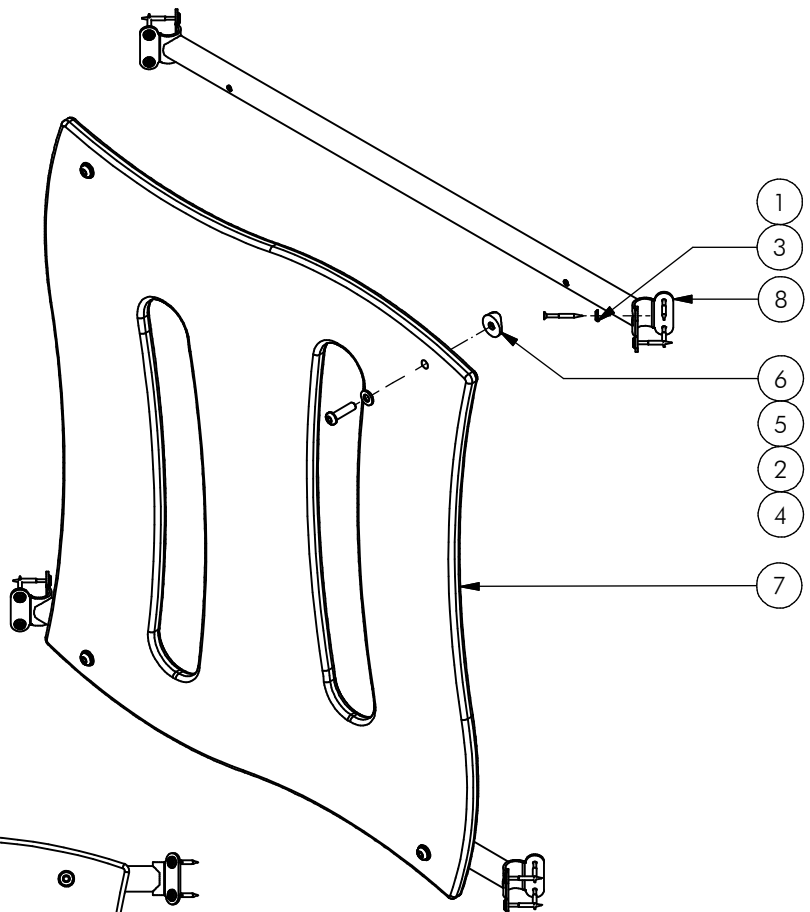

Bovenkant bordes
(Top platform)

Nr	#	Type	Progr.	Volgnr	Bew.	Rev.	Benaming	Opmerking
1	16	BSR	002	005	050		Schroef Assy	5 x 50 - RVS A2-70
2	4	BSR	023	010	040		Bolkopbout ISO 7380	M10 x 40 - RVS A2-70
3	16	BSR	036	005	015		Facet ring	M5 - RVS A2-70
4	4	KST	DOP	006	030		OPVULDOPJE	6 MM ROOD
5	4	KST	ROR	010	000		RING NYLON	M10 x 2.5 MM
6	4	KST	T33	010	000		ZADELRING	BUIS 33.7
7	1	OPE	VRB	002	030	G	WANDJE	SLEUF ROOD
8	2	SME	VRB	506	320	D	SYSTEEMBUIS	VRJIBUITER RVS



Benaming Title: WANDJE SLEUF
 Opmerking Comment: ROOD
 Datum Date: 17-2-2014

Tekening Drawing

MOD VRB HHT 011 A

Samenstelling module Assembly module

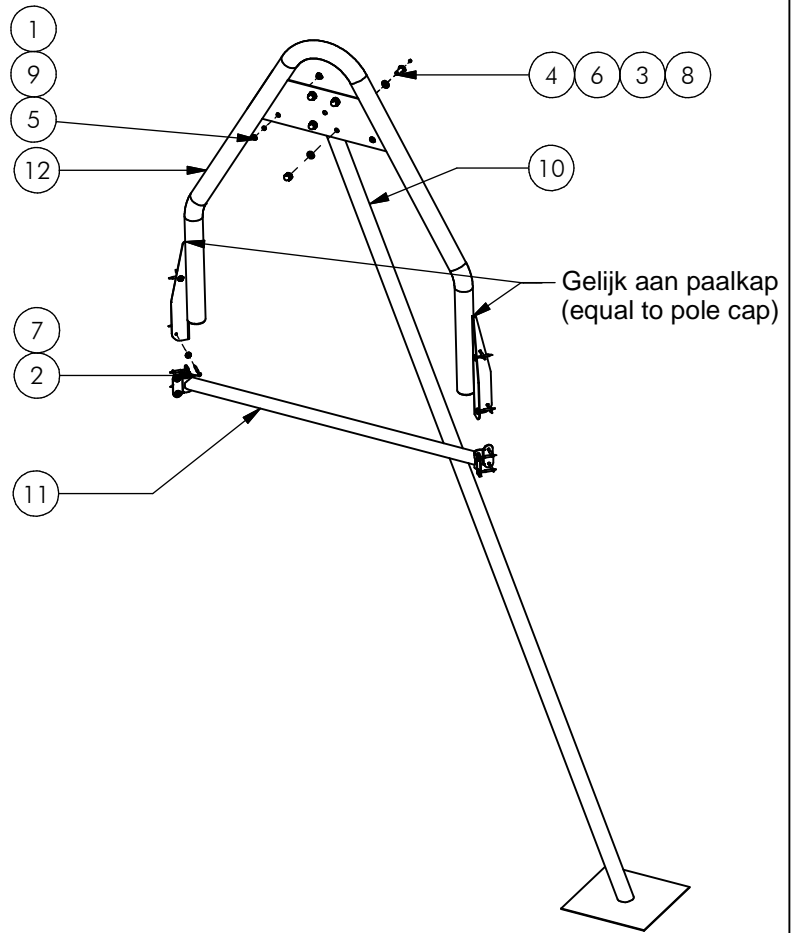
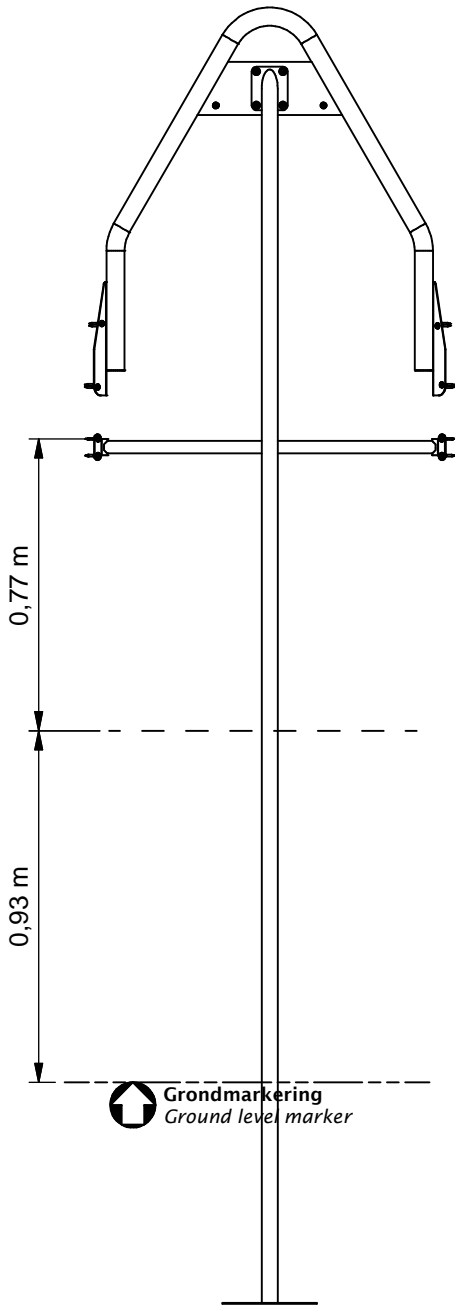

Nr	#	Type	Progr.	Volgnr	Bew.	Rev.	Benaming	Opmerking
1	2	BSA	014	004	054		POPNAGEL	GROTE KOP
2	16	BSR	002	005	050		Schroef Assy	5 x 50 - RVS A2-70
3	4	BSR	011	010	020		DOPMOER	BORG RVS M10
4	4	BSR	023	010	025		BOLKOP SCHROEF	ISO 7380 - M10 x 25
5	2	BSR	030	005	001		Sluitring	M5 - RVS A2-70
6	8	BSR	030	010	002		SLUITRING	M10
7	16	BSR	036	005	015		Facet ring	M5 - RVS A2-70
8	4	KST	DOP	006	030		OPVULDOPJE	6 MM ROOD
9	2	KST	RNG	005	003		RING	KUNSTSTOF
10	1	SME	VRB	005	320	E	GLIJPAAL	VLOER 93 CM
11	1	SME	VRB	505	320	D	SYSTEEMBUIS	VRIJBUITER RVS
12	1	SME	VRB	512	320	E	KLIM/GLIJ BEUGEL	RVS



Benaming
Title: GLIJPAAL

Opmerking
Comment: VLOER 93 CM

Datum
Date: 29-11-2016

Tekening
Drawing

MOD VRB HHT 022 A
 Samenstelling module Assembly module

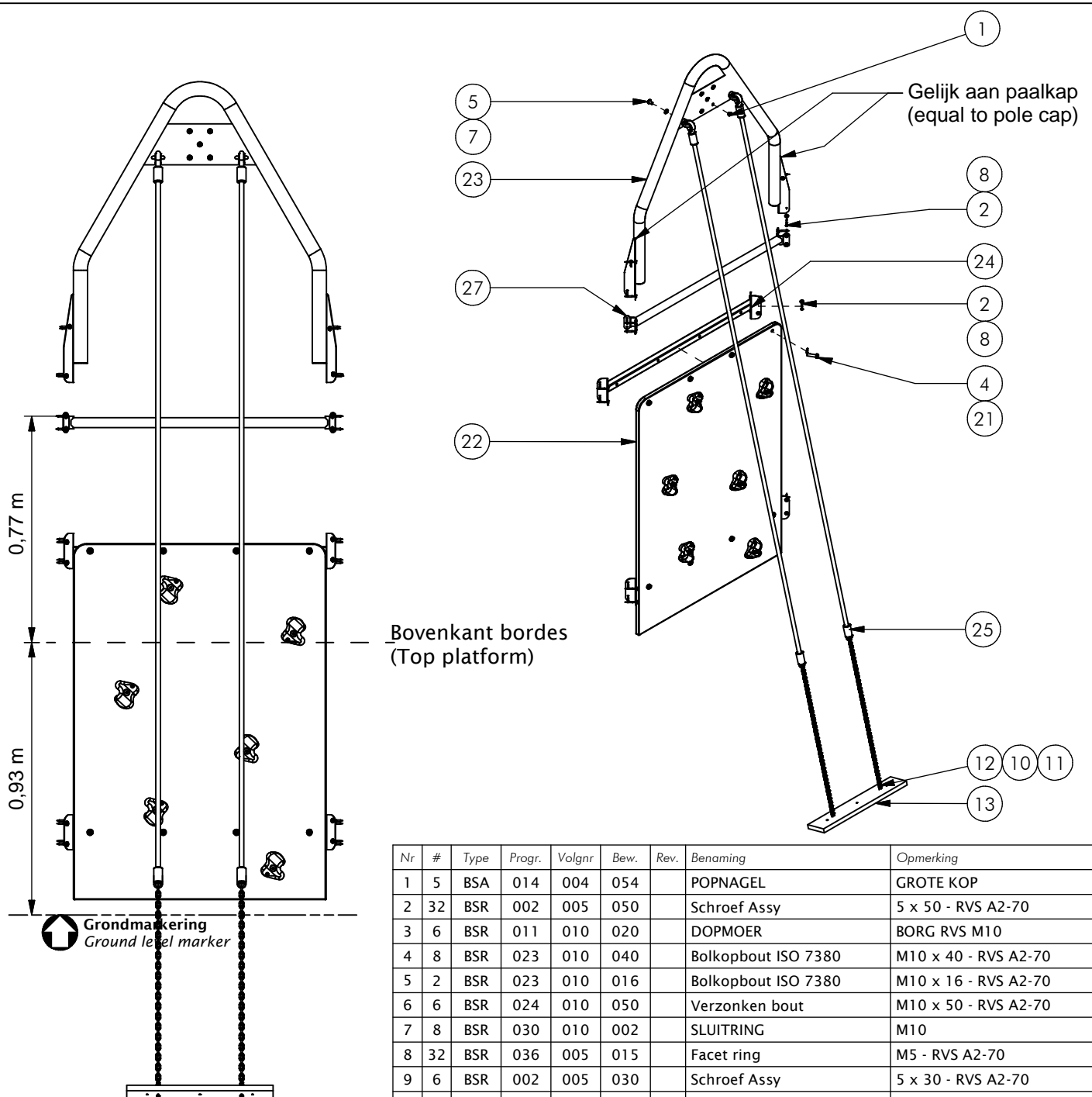

Nr	#	Type	Progr.	Volgnr	Bew.	Rev.	Benaming	Opmerking
1	5	BSA	014	004	054		POPNAGEL	GROTE KOP
2	32	BSR	002	005	050		Schroef Assy	5 x 50 - RVS A2-70
3	6	BSR	011	010	020		DOPMOER	BORG RVS M10
4	8	BSR	023	010	040		Bolkopbout ISO 7380	M10 x 40 - RVS A2-70
5	2	BSR	023	010	016		Bolkopbout ISO 7380	M10 x 16 - RVS A2-70
6	6	BSR	024	010	050		Verzonken bout	M10 x 50 - RVS A2-70
7	8	BSR	030	010	002		SLUITRING	M10
8	32	BSR	036	005	015		Facet ring	M5 - RVS A2-70
9	6	BSR	002	005	030		Schroef Assy	5 x 30 - RVS A2-70
10	2	BSV	017	006	005		Zeskantmoer	M6 - VZ 8.8
11	2	BSV	021	006	050		Zeskantbout ISO 4014	M6 x 50 - VZ 8.8
12	4	BSV	030	006	002		Sluitring	M6 - VZ 8.8
13	1	KST	APL	050			Ankerplaat	500x100x19
15	12	KST	DOP	006	030		OPVULDOPJE	6 MM ROOD
16	1	KST	KNP	010	040		KLIMGREEP	PAARS
17	1	KST	KNP	010	070		KLIMGREEP	GROEN
18	1	KST	KNP	010	050		KLIMGREEP	BLAUW
19	1	KST	KNP	010	010		KLIMGREEP	GEEL
20	2	KST	KNP	010	030		KLIMGREEP	ROOD
21	8	KST	ROR	010	000		RING NYLON	M10 x 2.5 MM
22	1	OPE	VRB	049	050	B	Klimwandplaat S4	Vrijbouter
23	1	SME	VRB	512	320	E	KLIM/GLIJ BEUGEL	RVS
24	2	SME	VRB	515	320	F	OPHANGKOKER	KLIMWAND
25	2	SNT	VRB	007	BLW	C	KLIMTOUW	335 CM
27	1	SME	VRB	505	320	D	SYSTEEMBUIS	VRIJBUIER RVS
28	4	KST	DOP	006	030		OPVULDOPJE	6 MM ROOD



Benaming
Title Klimwand 93 cm (S4)

Opmerking
Comment Touwen aan beugel

Datum
Date 29-11-2016

Tekening
Drawing

MOD VRB HHT 026 C
Samenstelling module Assembly module

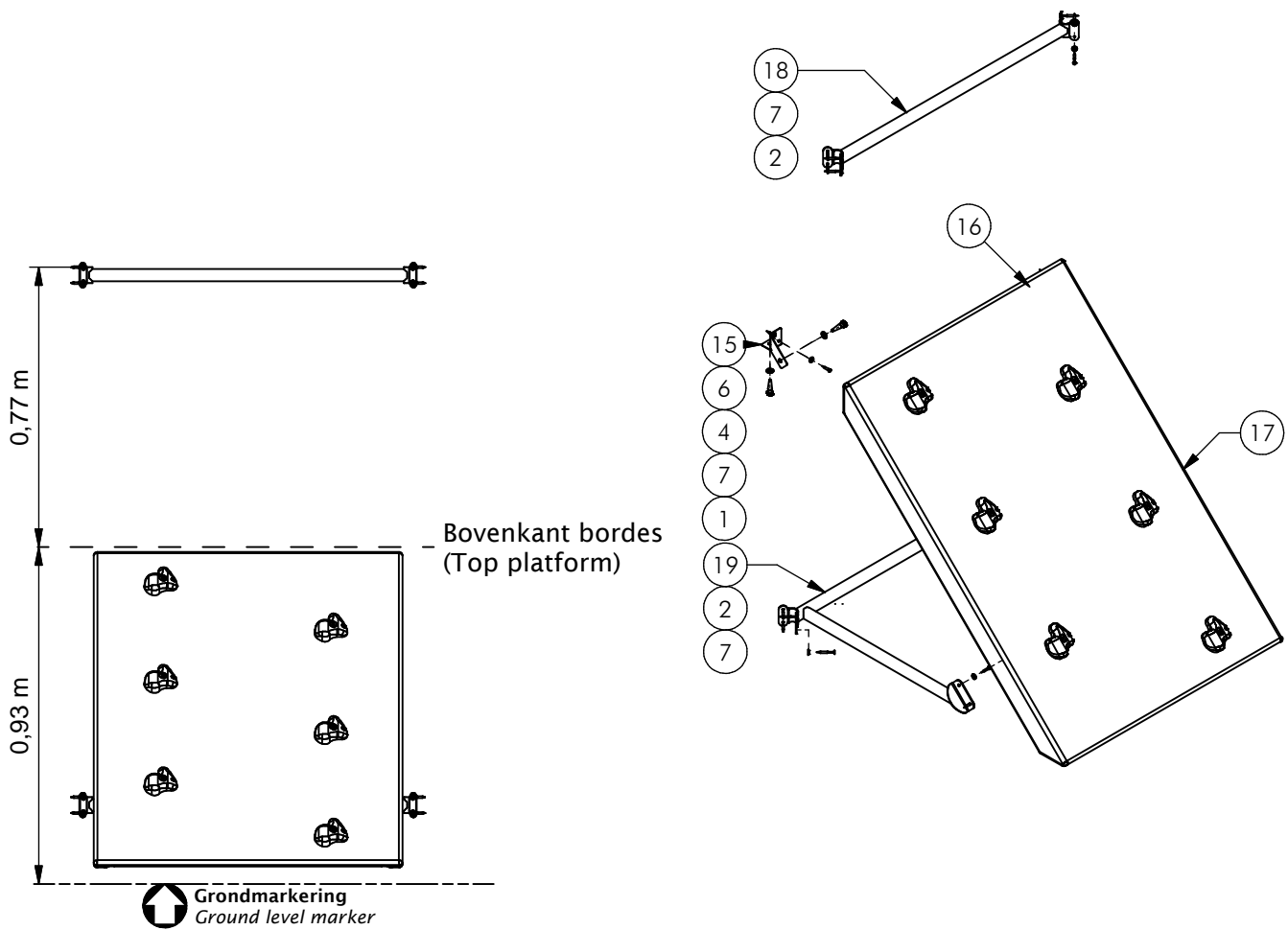

Nr	#	Type	Progr.	Volgnr	Bew.	Rev.	Benaming	Opmerking
1	14	BSR	002	005	030		Schroef Assy	5 x 30 - RVS A2-70
2	16	BSR	002	005	050		Schroef Assy	5 x 50 - RVS A2-70
3	6	BSR	011	010	020		DOPMOER	BORG RVS M10
4	4	BSR	022	010	040		Houtdraadbout	ø10 X 40 - RVS A2-70
5	6	BSR	024	010	050		Verzonken bout	M10 x 50 - RVS A2-70
6	10	BSR	030	010	002		SLUITRING	M10
7	24	BSR	036	005	015		Facet ring	M5 - RVS A2-70
8	4	KST	DOP	006	030		OPVULDOPJE	6 MM ROOD
9	1	KST	DOP	006	030		OPVULDOPJE	6 MM ROOD
10	1	KST	KNP	010	010		KLIMGREEP	GEEL
11	1	KST	KNP	010	050		KLIMGREEP	BLAUW
12	1	KST	KNP	010	070		KLIMGREEP	GROEN
13	2	KST	KNP	010	030		KLIMGREEP	ROOD
14	1	KST	KNP	010	040		KLIMGREEP	PAARS
15	1	OME	VRB	830	304		OPLOOP	BEUGEL LINKS
16	1	OME	VRB	831	304		OPLOOP	BEUGEL RECHTS
17	1	SHO	VRB	003	COA	B	OPLOOPPLAAT	VRIJBUIJTER
18	1	SME	VRB	505	320	D	SYSTEEMBUIS	VRIJBUIJTER RVS
19	1	SME	VRB	560	320	B	Steun	Oploop
20	2	KST	DOP	006	030		OPVULDOPJE	6 MM ROOD



Benaming
Title OPLOOP

Opmerking
Comment VRB

Datum
Date 25-9-2006

Tekening
Drawing

MOD VRB HHT 027

Samenstelling module Assembly module

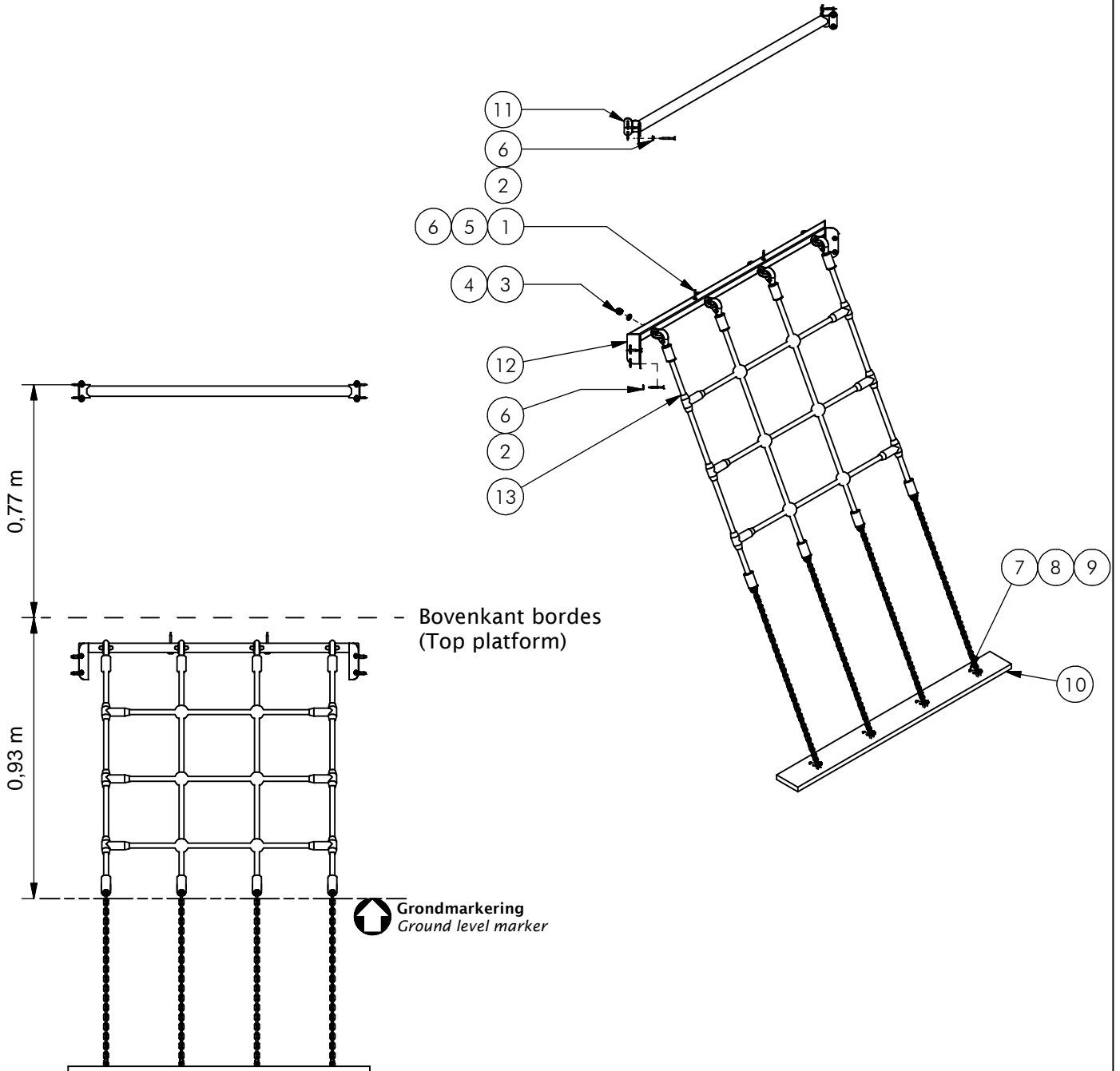

Nr	#	Type	Progr.	Volgnr	Bew.	Rev.	Benaming	Opmerking
1	2	BSR	002	005	070		Schroef Assy	5 x 70 - RVS A2-70
2	16	BSR	002	005	050		Schroef Assy	5 x 50 - RVS A2-70
3	4	BSR	011	010	020		DOPMOER	BORG RVS M10
4	4	BSR	030	010	002		SLUITRING	M10
5	2	BSR	035	006	020		Carrosserie ring	M6 - RVS A2-70
6	18	BSR	036	005	015		Facet ring	M5 - RVS A2-70
7	4	BSV	017	006	005		Zeskantmoer	M6 - VZ 8.8
8	4	BSV	021	006	050		Zeskantbout ISO 4014	M6 x 50 - VZ 8.8
9	8	BSV	030	006	002		Sluitring	M6 - VZ 8.8
10	1	KST	APL	100			Ankerplaat	1000x100x19
11	1	SME	VRB	505	320	D	SYSTEEMBUIJS	VRIJBUITER RVS
12	1	SME	VRB	562	320		VLOERKOKER	HANGNET
13	1	SNT	VRB	005	BLW	D	OPLOOPNET	VRIJBUITER

Let op: Net zodanig plaatsen dat het slap hangt.



Benaming
Title Oploopnet

Opmerking
Comment Vloer S4

Datum
Date 18-12-2014

Tekening
Drawing

MOD VRB HHT 031 B
 Samenstelling module Assembly module

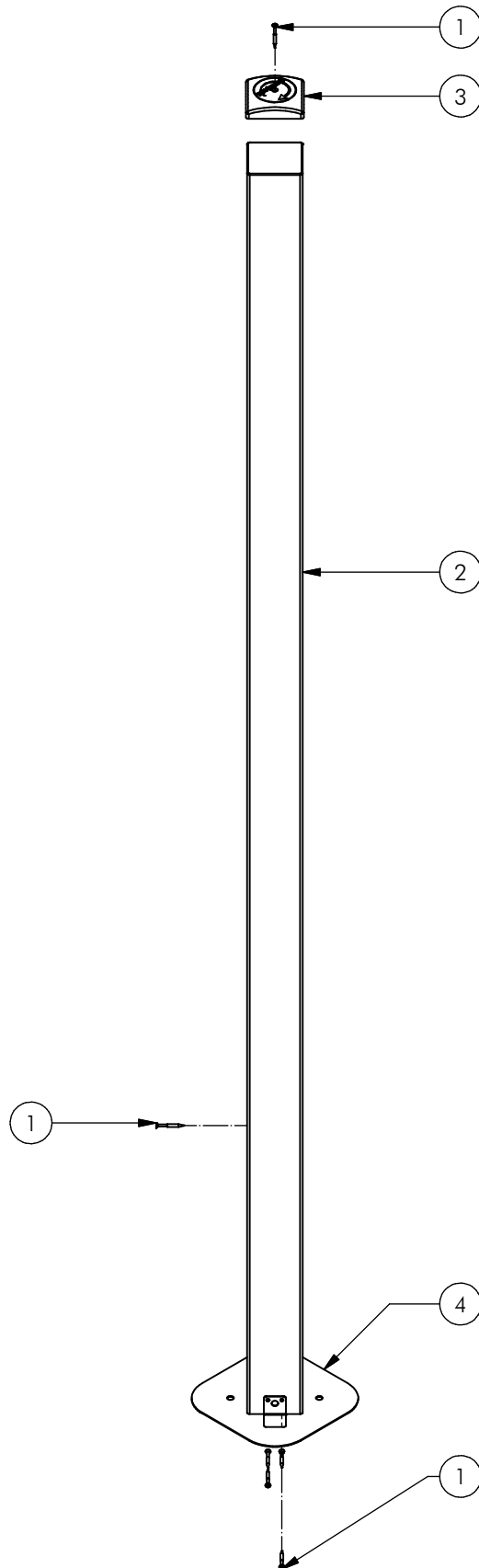

Nr	#	Type	Progr.	Volgnr	Bew.	Rev.	Benaming	Opmerking
1	6	BSR	002	005	050		SCHROEF	5 x 50
2	1	OHO	HHT	100	012		Staander HHT	100x100, lengte=2730
3	1	OME	KAP	100	ZMK		PAALKAP 100	Zamak, RAL 5003
4	1	OME	VRB	903	VZP	C	Voetplaat	100 x 100



Benaming
Title STAANDER

Opmerking
Comment 213 CM

Datum
Date 22-11-2006

Tekening
Drawing

MOD VRB HHT 052

Samenstelling module Assembly module

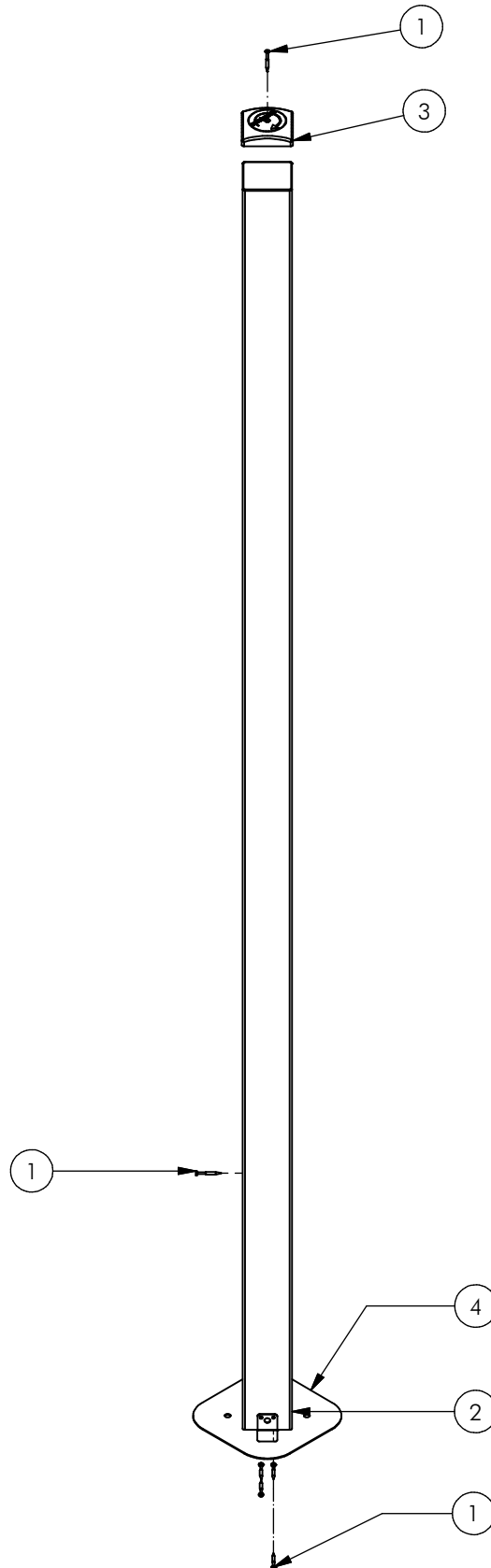

Nr	#	Type	Progr.	Volgnr	Bew.	Rev.	Benaming	Opmerking
1	6	BSR	002	005	050		SCHROEF	5 x 50
2	1	OHO	HHT	100	013		Staander HHT	100x100, lengte=3070
3	1	OME	KAP	100	ZMK		PAALKAP 100	Zamak, RAL 5003
4	1	OME	VRB	903	VZP	C	Voetplaat	100 x 100



Benaming
Title: STAANDER

Opmerking
Comment: 247 CM

Datum
Date: 9-5-2007

Tekening
Drawing

MOD VRB HHT 054

Samenstelling module *Assembly module*

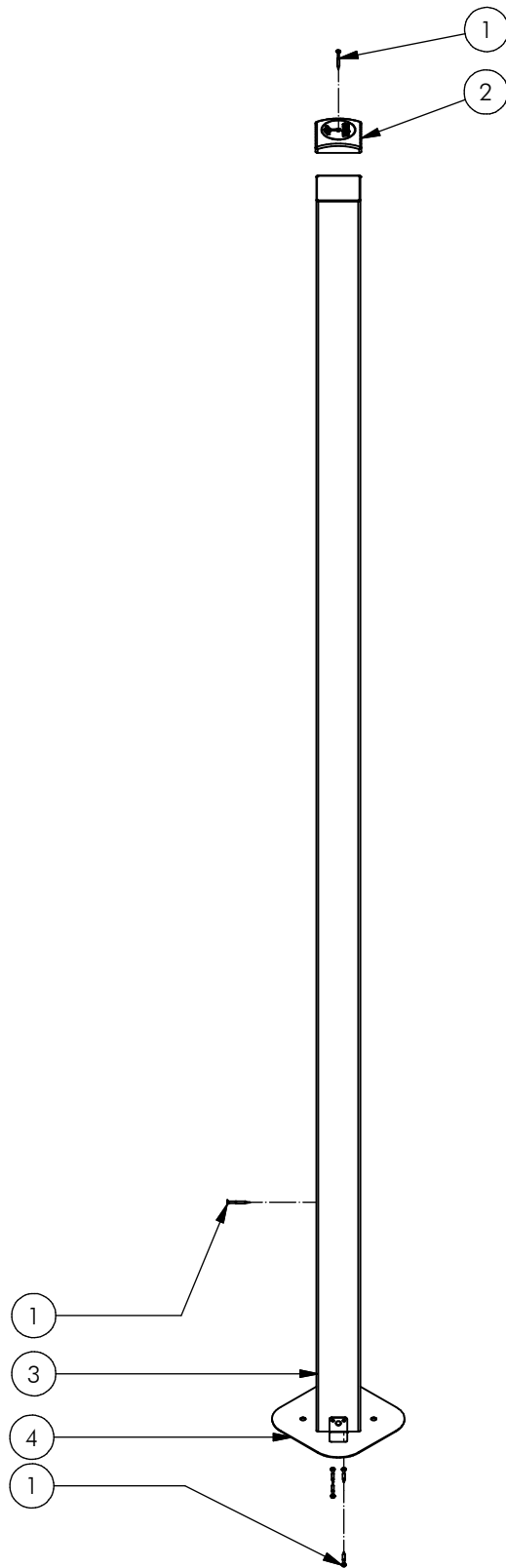

POS	N	TYPE	PROJ.	NR.	BEH.	R	BENAMING	OPMERKING
1	6	BSR	002	005	050		Schroef Assy	5 x 50 - RVS A2-70
2	1	OME	KAP	100	502	B	Paalkap 100x100	Aluminium
3	1	OHO	HHT	100	014		Staander HHT	100x100, lengte=3410
4	1	OME	VRB	903	VZP	C	Voetplaat	100 x 100



Benaming
Title | STAANDER

Opmerking
Comment | 281 CM

Datum
Date | 9-5-2007

Tekening
Drawing

MOD VRB HHT 055

Modules Modules

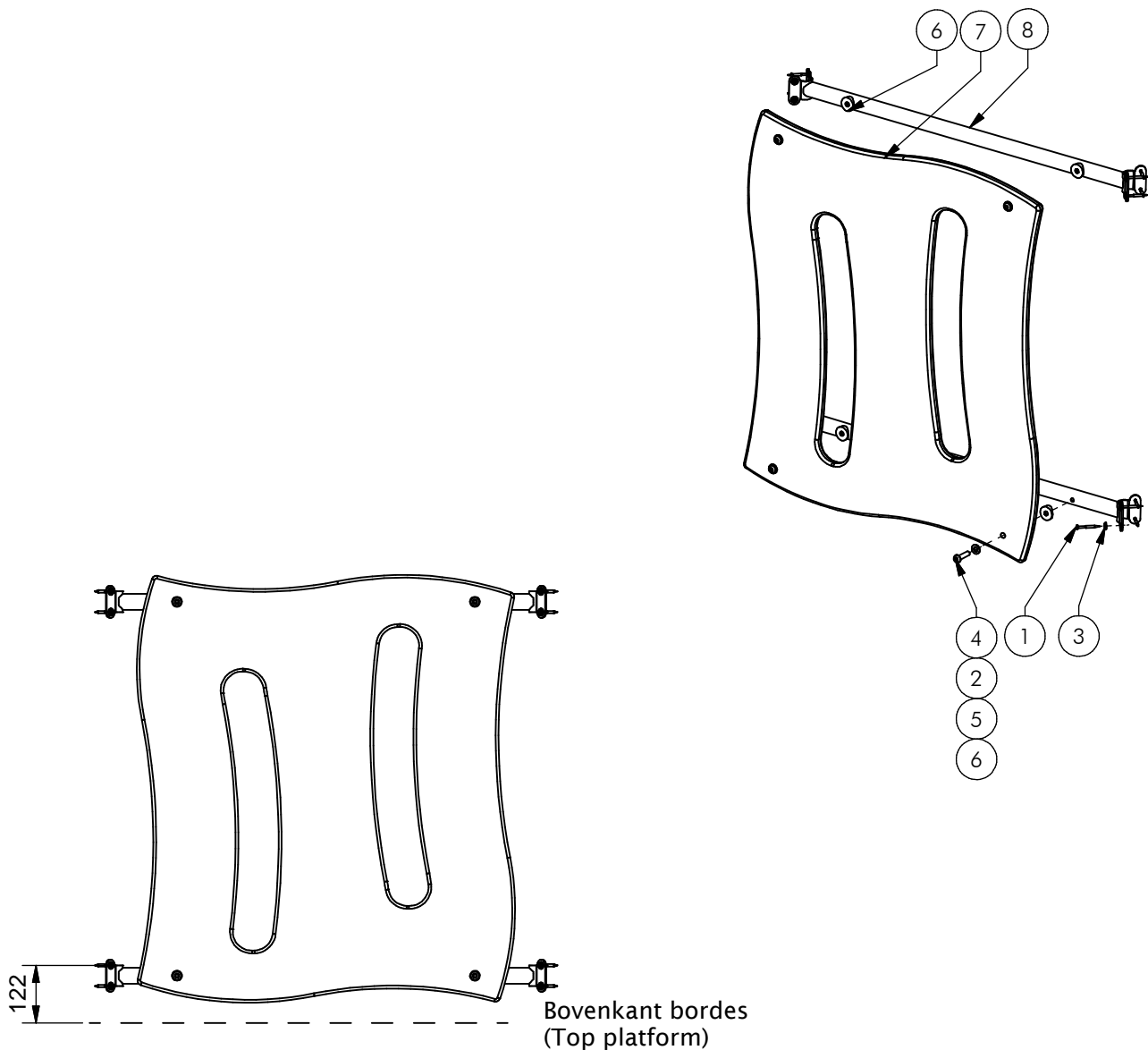

Nr	#	Type	Progr.	Volgnr	Bew.	Rev.	Benaming	Opmerking
1	16	BSR	002	005	050		SCHROEF	5 x 50
2	4	BSR	023	010	040		Bolkopbout ISO 7380	M10 x 40 - RVS A2-70
3	16	BSR	036	005	015		Facet ring	M5 - RVS A2-70
4	4	KST	DOP	006	030		OPVULDOPJE	6 MM ROOD
5	4	KST	ROR	010	000		RING NYLON	M10 x 2.5 MM
6	4	KST	T33	010	000		ZADELRING	BUIS 33.7
7	1	OPE	VRB	002	050	G	WANDJE	SLEUF BLAUW
8	2	SME	VRB	506	320	D	SYSTEEMBUIS	VRIJBUITER RVS



Benaming
Title | WANDJE SLEUF

Opmerking
Comment | BLAUW

Datum
Date | 17-2-2014

Tekening
Drawing

MOD VRB HHT 059 A
 Samenstelling module *Assembly module*

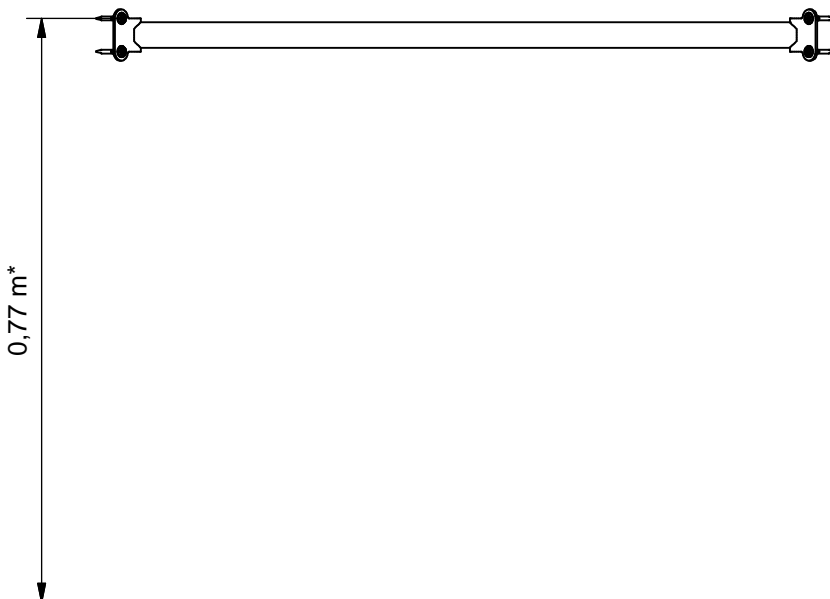
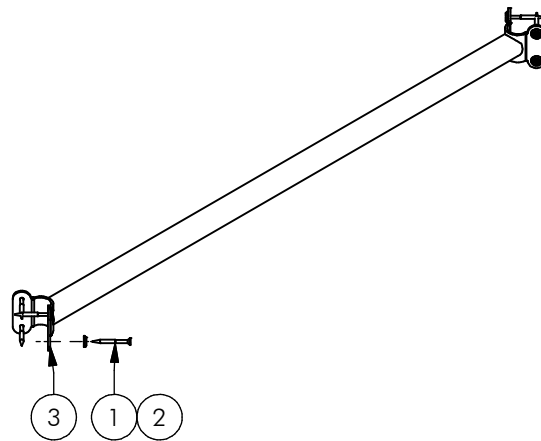

Bovenkant bordes
(Top platform)

*Gebruikt als railing
*Used as railing

Nr	#	Type	Progr.	Volgnr	Bew.	Rev.	Benaming	Opmerking
1	8	BSR	002	005	050		Schroef Assy	5 x 50 - RVS A2-70
2	8	BSR	036	005	015		Facet ring	M5 - RVS A2-70
3	1	SME	VRB	505	320	D	SYSTEEMBUIS	VRJIBUITER RVS



Benaming
Title | SYSTEEMBUIS
Opmerking
Comment | ENKEL
Datum
Date | 25-9-2006

Tekening
Drawing

MOD VRB HHT 075

Samenstelling module Assembly module

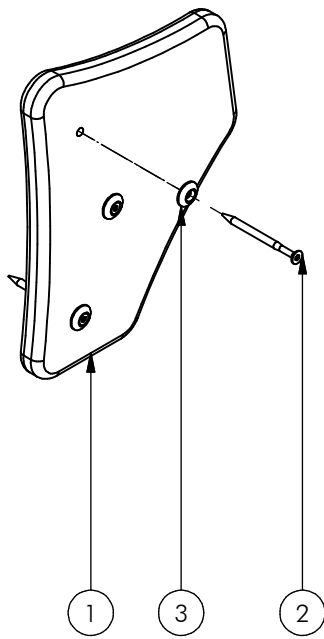
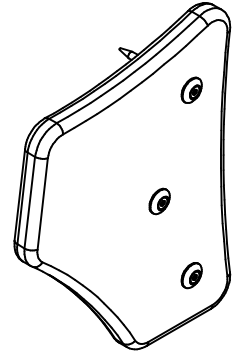

3	6	KST	ROR	006	000		ROZETRING M5	ZWART
2	6	BSR	002	005	070		Schroef Assy	5 x 70 - RVS A2-70
1	2	OPE	VRB	041	030	A	Afdekking	Glijbaan op diagonaalvloer
POS	N	TYPE	PROJ	NR.	BEH.	R	BENAMING	OPMERKING



Benaming
Title Valbeveiliging

Opmerking
Comment Rechthoekvloer

Datum
Date 12-3-2014

Tekening
Drawing

MOD VRB HHT 189 A
 Samenstelling module *Assembly module*

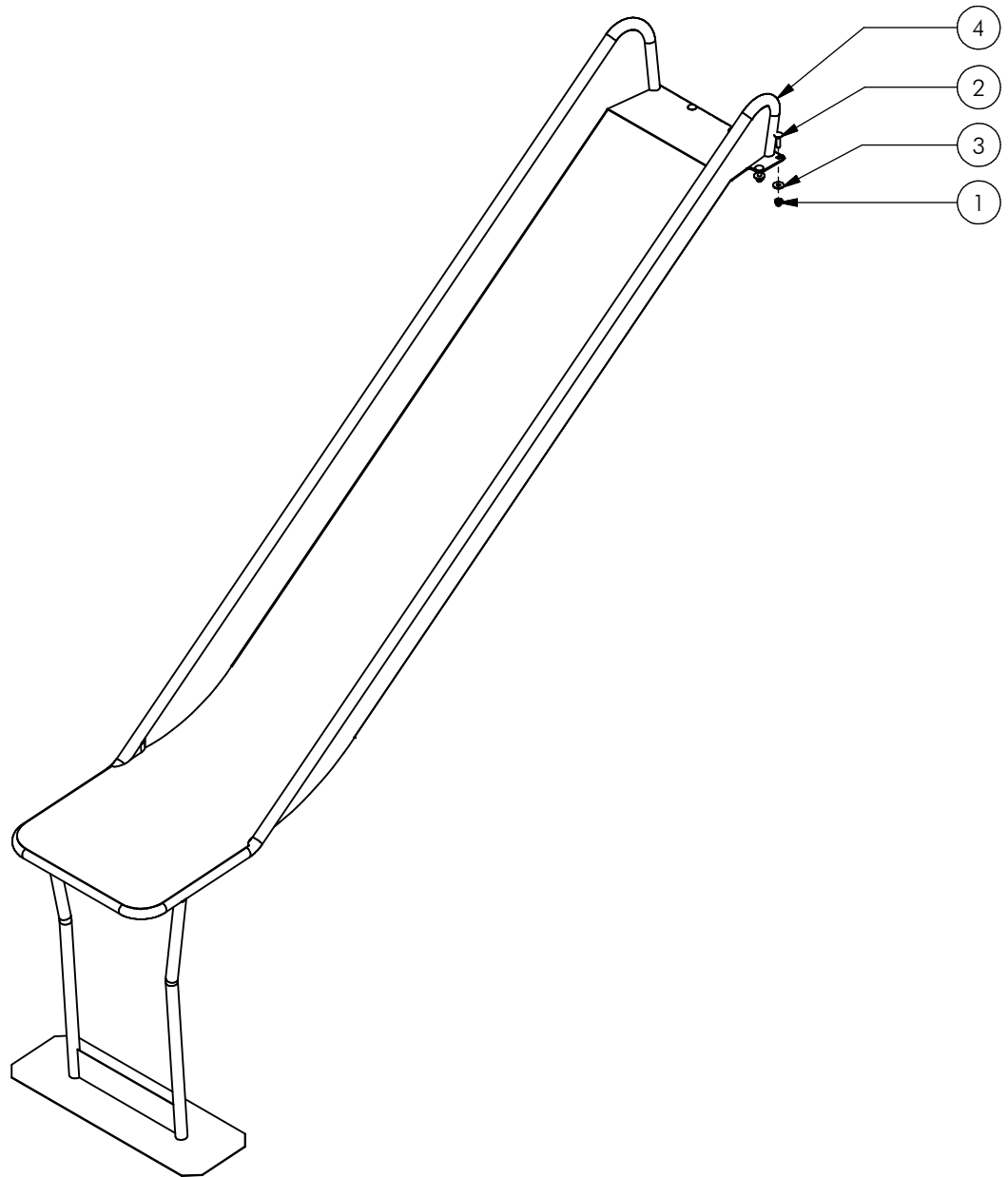
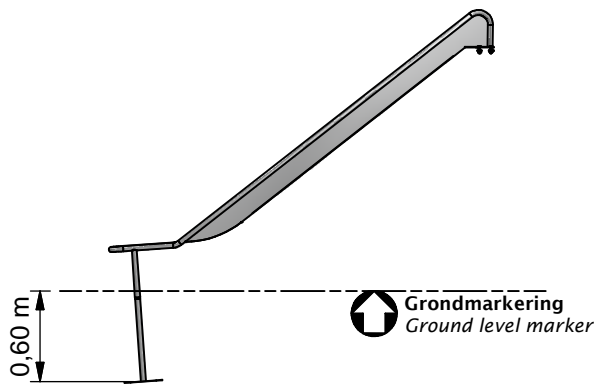

Let op: toestel bij voorkeur niet met de glijbaan op het zuiden plaatsen.

Attention: it is advisable not to orient playground equipment with the slide facing south

Nr	#	Type	Progr.	Volgnr	Bew.	Rev.	Benaming	Opmerking
1	6	BSR	011	010	020		DOPMOER	BORG RVS M10
2	6	BSR	026	010	040		Slotbout	M10 x 40 - RVS A2-70
3	6	BSR	035	010	030		Carrosserie ring	M10 - RVS A2-70
4	1	SME	VRB	613	320	B	Glijbaan	161 cm



Benaming / Title: Glijbaan 161 cm
 Opmerking / Comment: Module HHT
 Datum / Date: 3-12-2008

Tekening / Drawing

MOD VRB HHT 192

Samenstelling module Assembly module

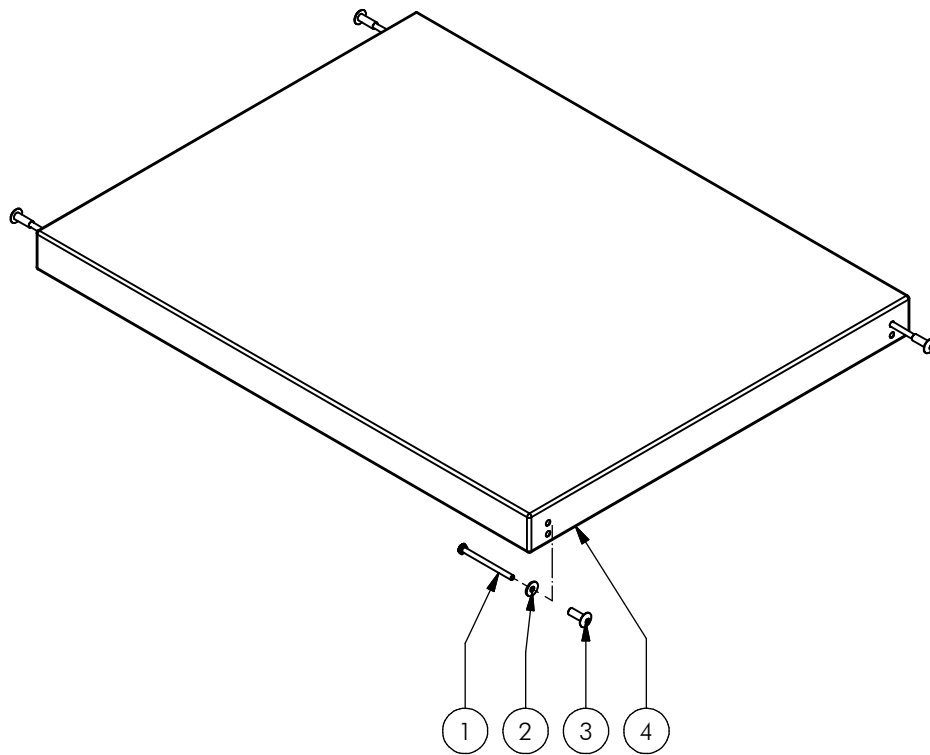

4	1	SHO	VRB	011	COA	Koppelvloer	VRB Diagonaal
3	4	RNT	BUS	M10	040	DRAADBUS	M10 x 40
2	4	BSR	035	010	030	CARROSSIERING	M10 x 30 x 2,5
1	4	BSR	021	010	130	ZESKANTBOUT	M10 x 130
POS	N	TYPE	PROJ.	NR.	BEH.	R	BENAMING
							OPMERKING



Benaming
Title Koppelvloer

Opmerking
Comment Diagonaal

Datum
Date 6-1-2009

Tekening
Drawing

MOD VRB HHT 194

Samenstelling module *Assembly module*

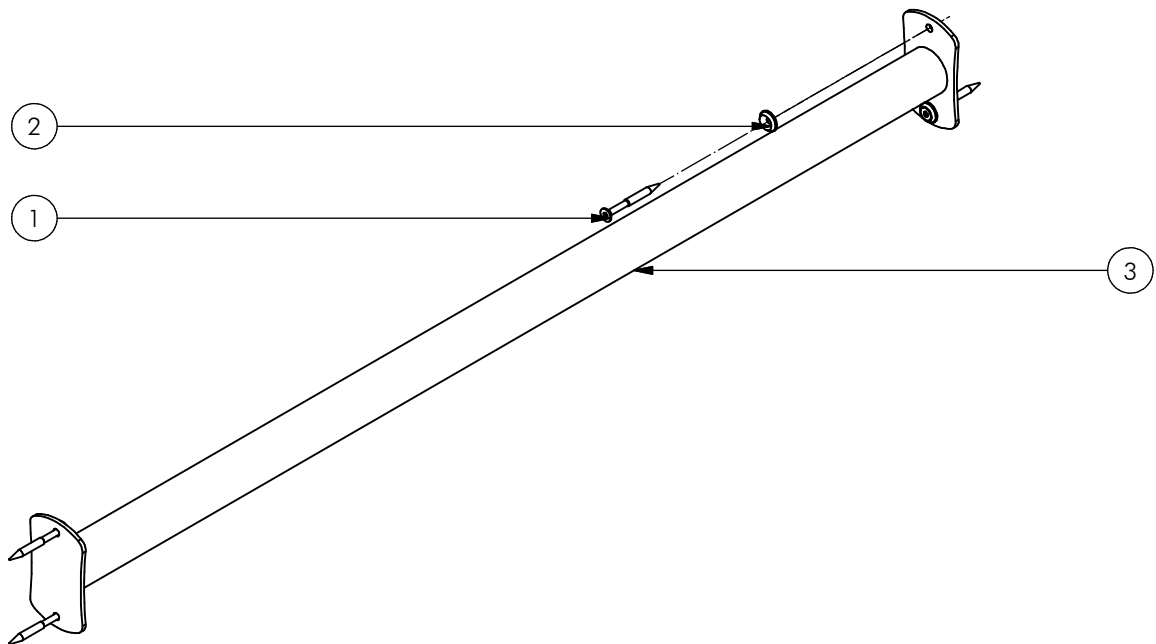

Nr	#	Type	Progr.	Volgnr	Bew.	Rev.	Benaming	Opmerking
1	4	BSR	002	005	050		SCHROEF	5 x 50
2	4	BSR	036	005	015		Facet ring	M5 - RVS A2-70
3	1	SME	KKB	001	320	A	Systeembuis	Kiekeboe



Benaming
Title: Systeembuis

Opmerking
Comment: 820 mm

Datum
Date: 5-1-2016

Tekening
Drawing

MOD VRB HHT 656

Samenstelling module *Assembly module*