

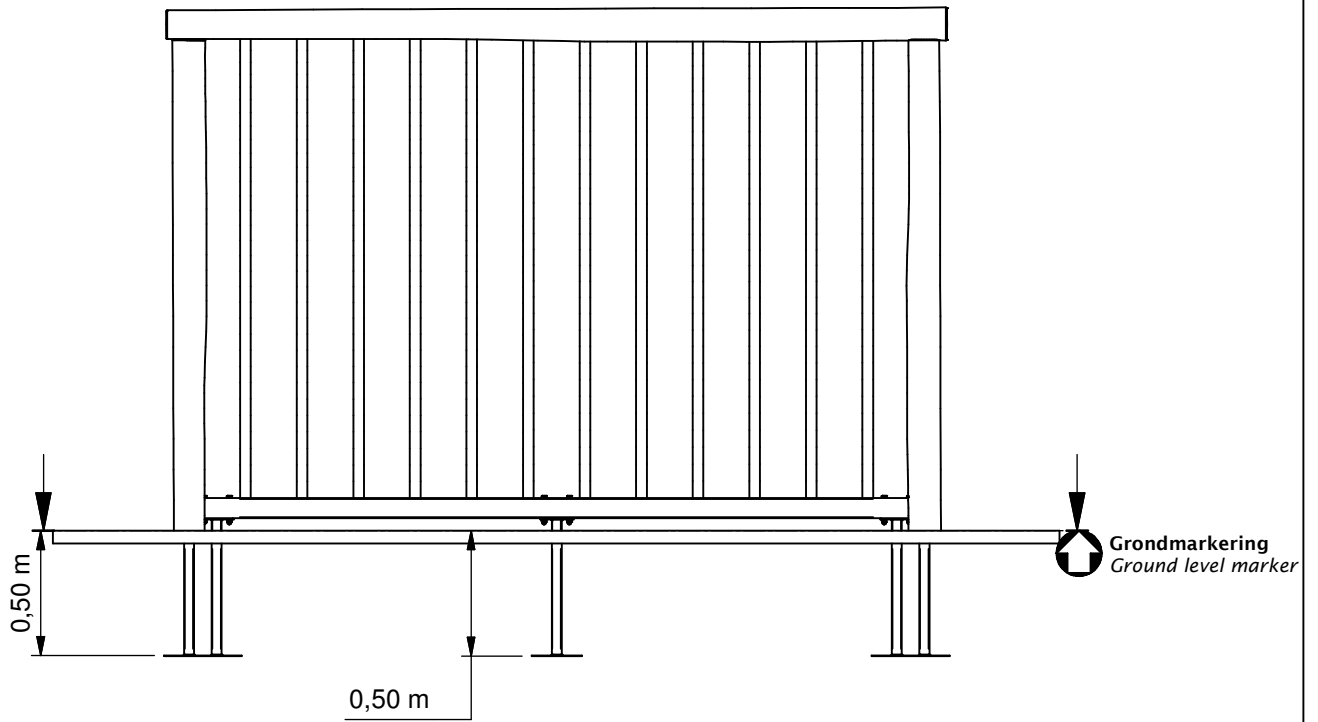

Goal

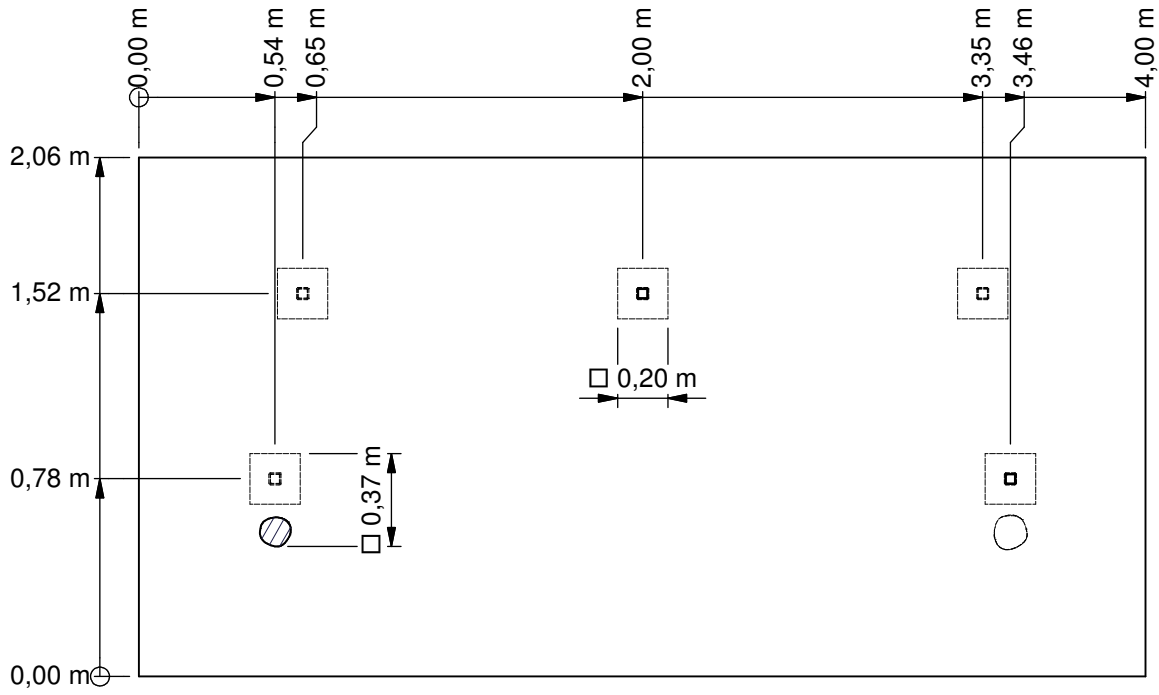

PSTE000.400



Benaming
Title Voorzetgoal

Opmerking
Comment AVP

Datum
Date 15-7-2011

Tekening
Drawing

TOE PST 000 400

Bodemplan Groundplan

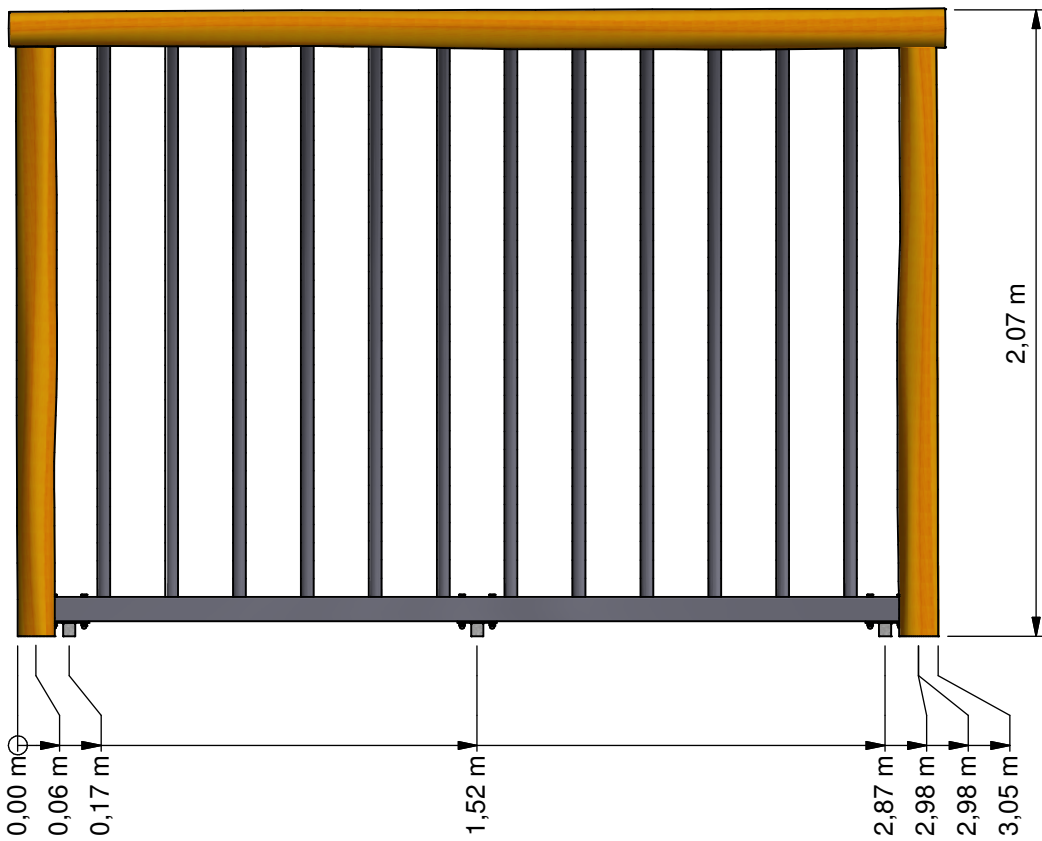
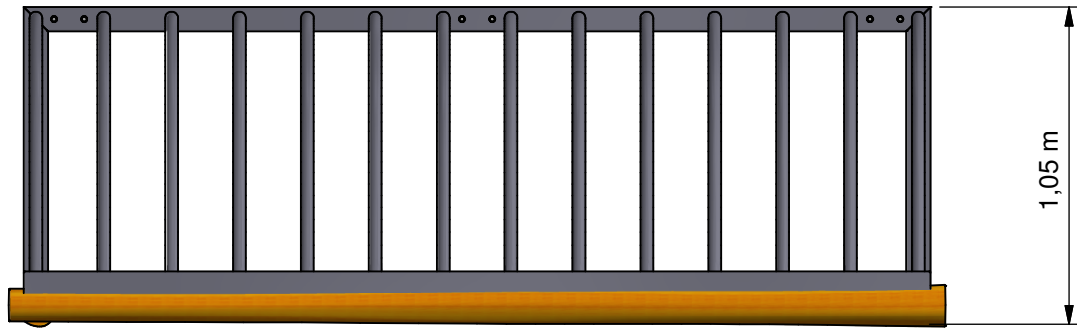

Benaming
Title Voorzetgoal

Opmerking
Comment AVP

Datum
Date 15-7-2011

Tekening
Drawing

TOE PST 000 400

Afmetingen Dimensions

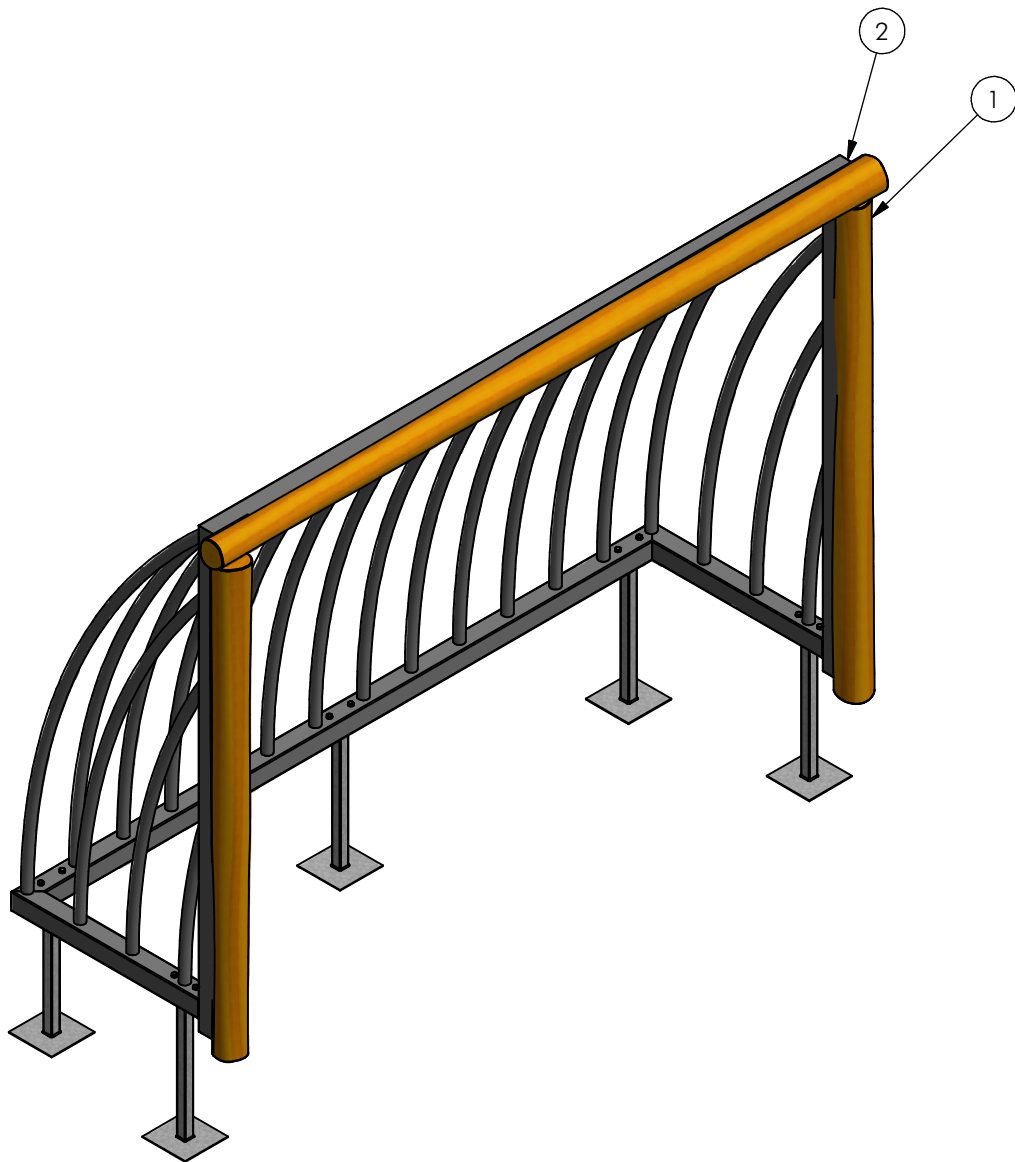

Nr	#	Type	Progr.	Volgnr	Bew.	Rev.	Benaming	Opmerking
1	1	MOD	PST	015	020		Voorzetgoal	Adventure Play
2	1	MOD	SOL	435			Maxigoal	met grondankers



Benaming
Title | Voorzetgoal

Opmerking
Comment | AVP

Datum
Date | 15-7-2011

Tekening
Drawing

TOE PST 000 400

Modules Modules

PSTE000.400

Goal

LOGBOOK

(Onderstaand logboek kan gebruikt worden om te voldoen aan de eisen, gesteld in artikel 14 van het Warenwetbesluit Attractie- en Speeltoestellen)

Type indication	Sports equipment
Product code	PSTE000.400
Name of equipment	Goal 3x2m Hout+Metaal
Maximum height of fall	n.a.
Year of construction	2017
Certificate	0183402366
inspection authority	NVT -
Name manufacturer	BOERplay Hyacintstraat 2 - 4255 HX Nieuwendijk Phone: +31 (0)183 40 23 66 Fax: +31 (0)183 40 35 64
name installer	_____ _____
Description of equipment	Goal
Location of equipment	_____
Data about the owner of the play equipment	
Name:	_____
Address:	_____
Postcode and town:	_____
Contact person:	_____
Telephone number:	_____
Data about the administrator of the play equipment	
Name:	_____
Address:	_____
Postcode and town:	_____
Contact person:	_____
Telephone number:	_____

LOGBOOK

Inspection and maintenance intervals



Nr.	Inspection	Maintenance	months between inspections
1	Verify equipment's stability, junctions and missing parts. Inspect bolts, screws and nuts for absence, jams, corrosion and wear.	Add missing parts, secure joints, apply missing fixing agent and replace corroded parts.	1
2	Check suspension for wear.	Replace worn parts and/or remove non-functioning parts.	1
3	Inspect rotating parts such as hinges, rolling-element bearings, etc. for wear and acceptability.	Replace worn parts and/or remove non-functioning parts.	1
4	Check wood for splinters, unacceptable damage and signs of rot. Especially at ground level.	Repair damage. Replace affected wood. Smoothen splintered wood and sharp edges.	1
5	Inspect foundation for stability, tearing and coverage.	Restore foundation and covering material.	3
6	Examine rubber and synthetic parts for wear, damage and break.	Replace original parts.	3
7	Inspect metal for corrosion and damage in the coating.	Restore any damaged coating (after removing rust and applying primer).	6
8	Check ropes, cables, chains and nets for wear and damage. Steel cables and nets which are tensioned must be checked for tension.	Replace parts where necessary. Steel cables and nets must be tensioned.	3
9	Inspect equipment for unsafe changes and additions.	Remove unsafe additions and correct unsafe changes.	1
10	Inspect safety surfaces.	Restore and repair where necessary.	1

Remarks

1. If used intensively, all points require extra attention.
2. Extreme weather conditions and locations may require a higher inspection frequency. Discuss this with the supplier.
3. Vandalism-sensitive locations require stricter inspections, possibly daily.
4. Check the terrain regularly for items that do not belong there, are unsafe or may be used wrongly. Examples are poisonous plants, glass shards, etc. Frequency depends on strain.
5. Remember that bad maintenance leads to unsafe conditions and notably faster impoverishment of the playground area.
6. Replacement parts can be ordered at the manufacturer with the part numbers on the module drawing. Drawings can be found in de user guide.
7. The impact area shall be provided with impact attenuating surface according to the specified falling height.
8. This list is conform the CEN-standard "playground equipment and surfacing NEN-EN 1176-7".



Dit toestel is geen speeltoestel conform het warenwetbesluit attractie- en speeltoestellen, en is dus niet als zodanig gecertificeerd.

This equipment is not playground equipment, so it has not been certified as such.



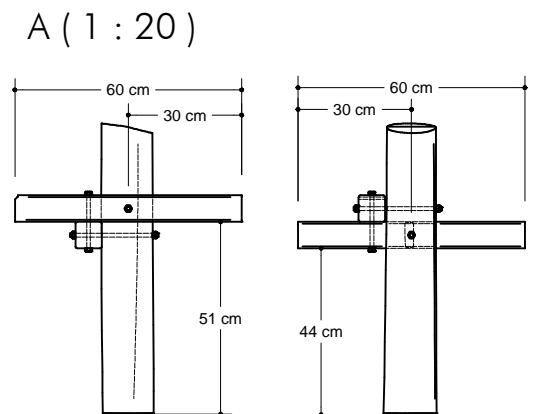
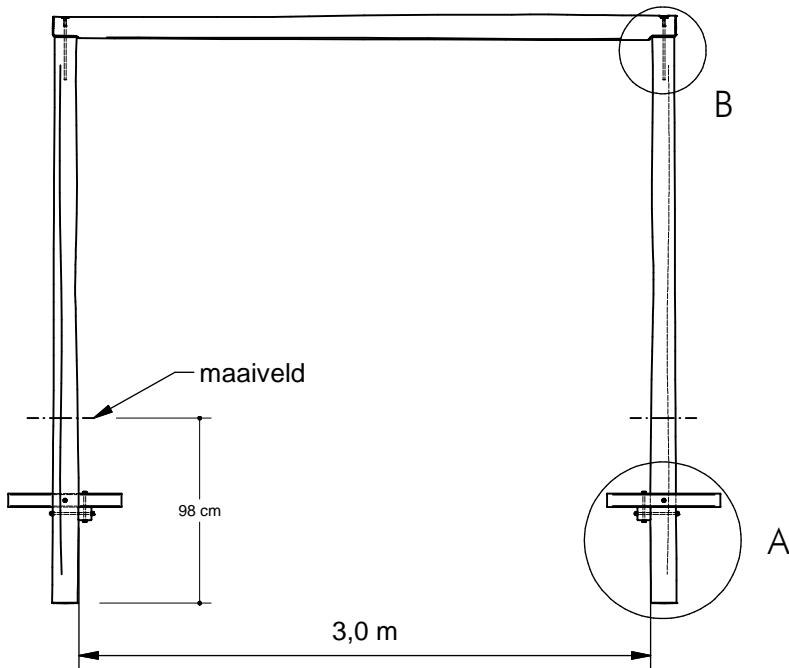
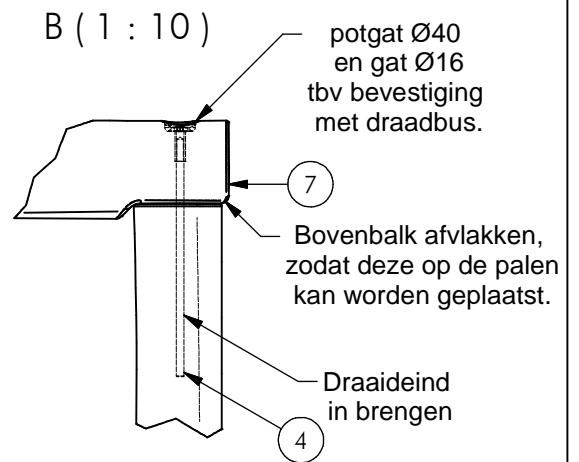
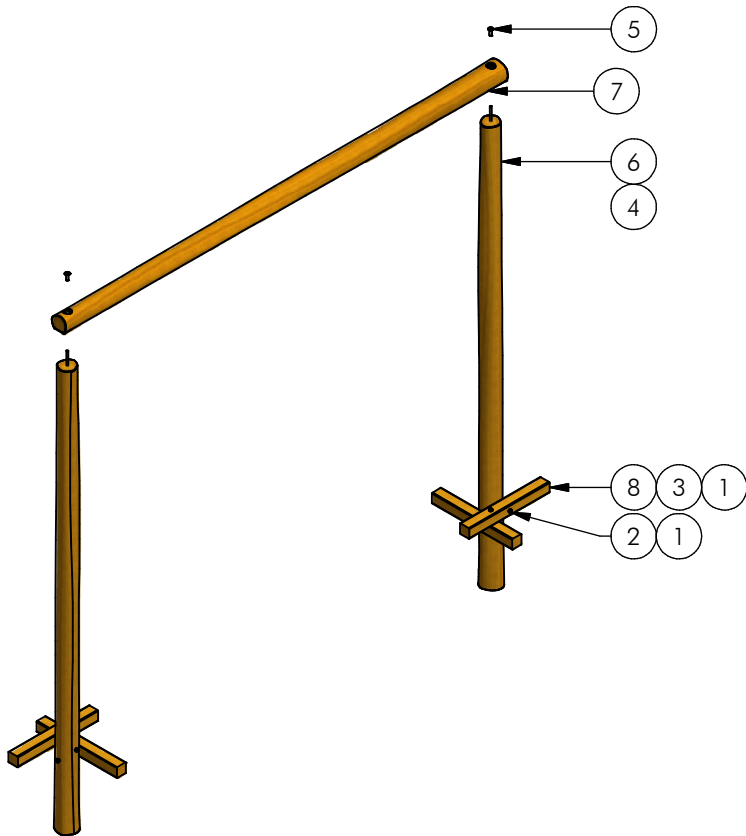

8	4	OHO	PST	307	060	70 mm Vierkante paal	600 mm Lengte	
7	1	OHO	PST	140	033	Paal 12-14	Lengte =3300	
6	2	OHO	PST	140	030	Paal 12-14	Lengte =3000	
5	2	BSR	BUS	M10	040	DRAADBUS	M10 x 40	
4	2	BSR	070	010	320	DRAADEIND	M10 x 330	
3	2	BSR	070	010	160	DRAADEIND	M10 x 160	
2	4	BSR	070	010	230	DRAADEIND	M10 x 230	
1	12	BSR	010	010	010	BORGMOER	M10	
POS	N	TYPE	PROJ	NR.	BEH.	R	BENAMING	OPMERKING

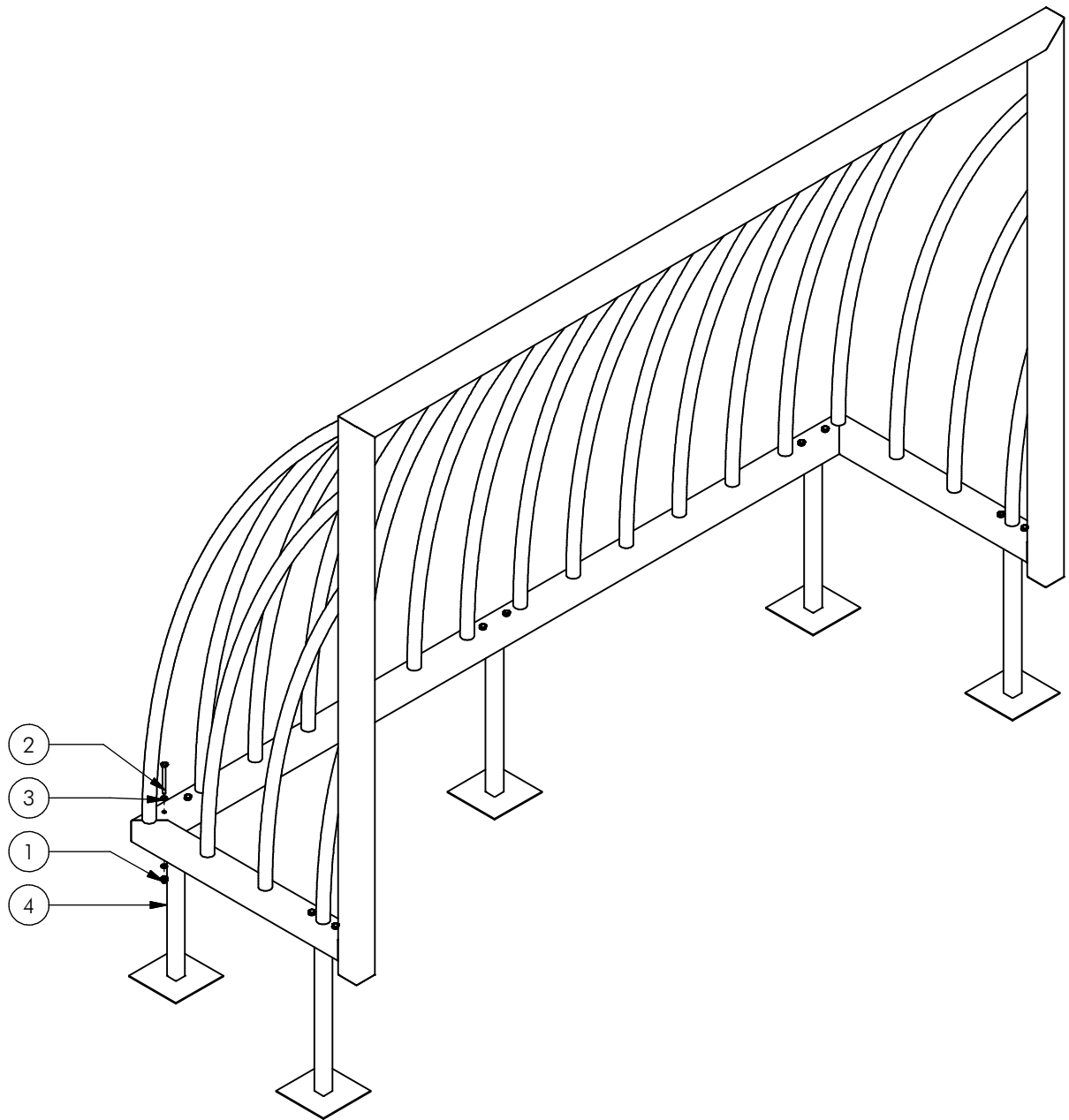

Nr.	#	Type	Progr.	Volgnr.	Bew.	Rev.	Benaming	Opmerking
1	10	BSV	011	010	020		Borgdopmoer	M10 - VZ 8.8
2	10	BSV	021	010	100		Zeskantbout ISO 4014	M10 x 100 - VZ 8.8
3	20	BSV	030	010	002		SLUITRING	M10 VZ
4	5	SME	SOL	032	372	D	Grondanker	Goal
5	1	SME	SOL	183	372		Maxigoal	Verzinkt



Benaming
Title Maxigoal

Opmerking
Comment met grondankers

Datum
Date 12-10-2017

Tekening
Drawing

MOD SOL 435

Samenstelling module *Assembly module*