

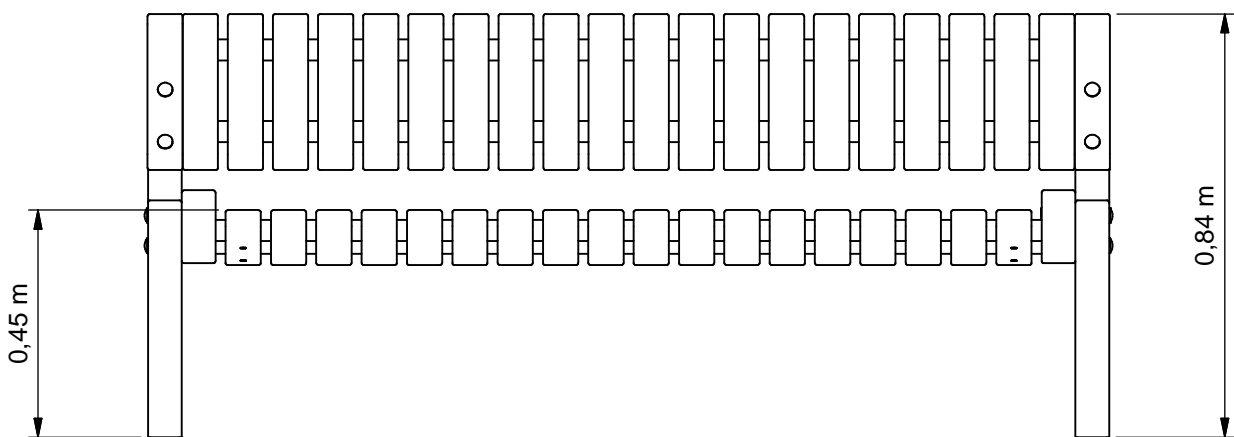

Bench

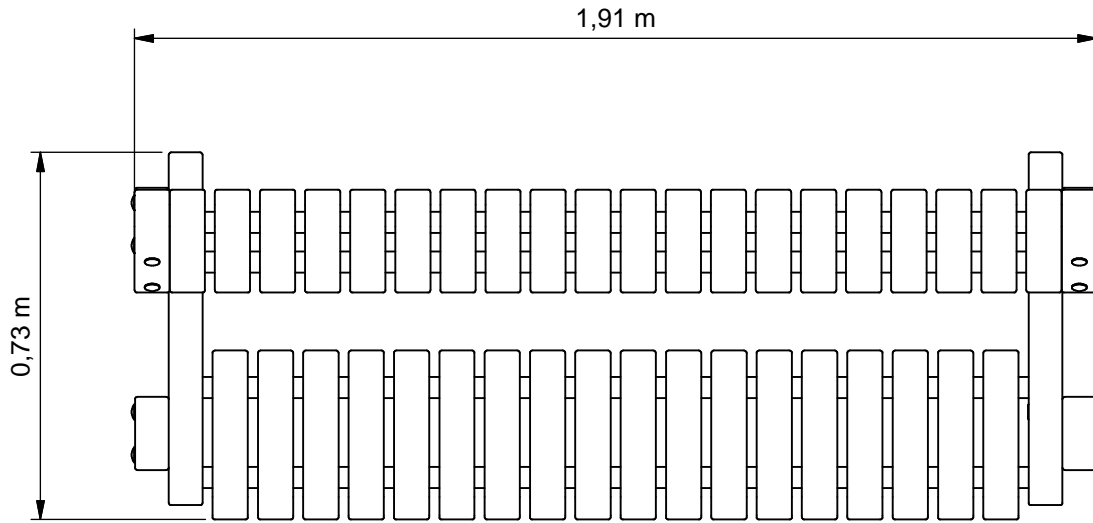

PKNE103.130



Benaming
Title | Parkbank

Opmerking
Comment | Rebo

Datum
Date | 26-10-2015

Tekening
Drawing

TOE PKN 103 130

Hoofdafmetingen Main dimensions

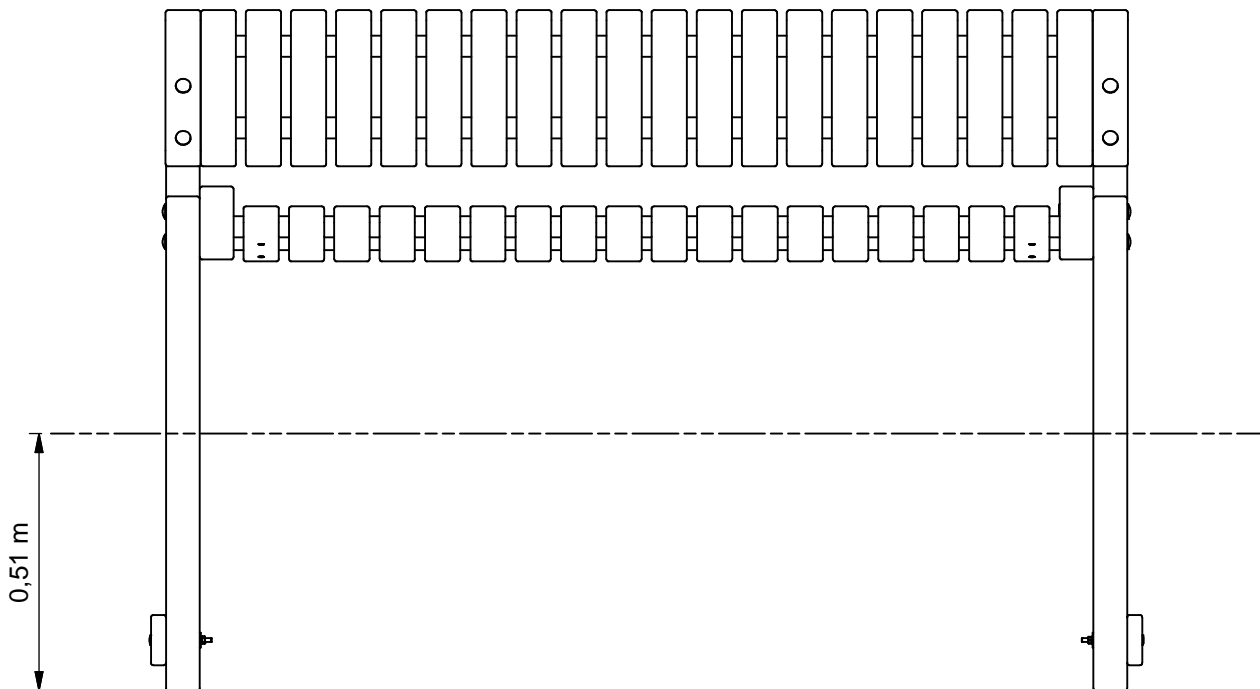
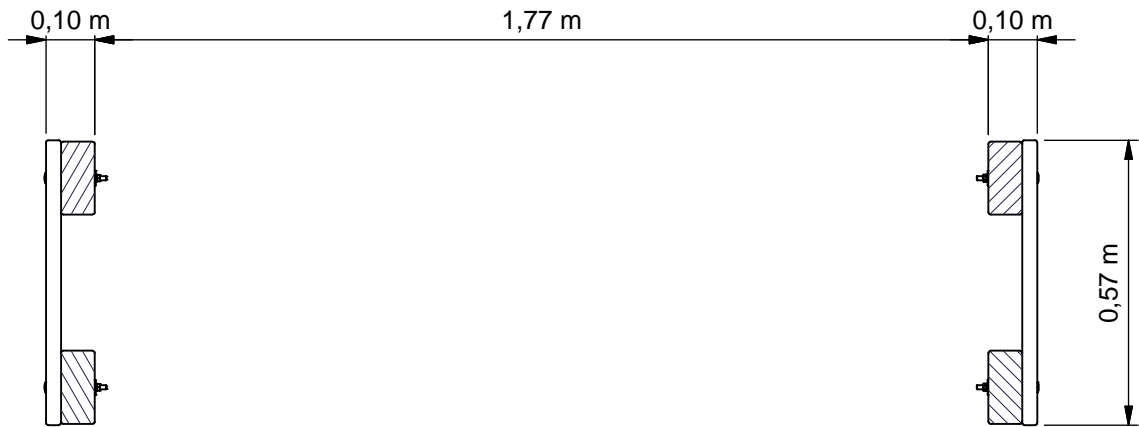

Benaming
Title Parkbank

Opmerking
Comment Rebo

Datum
Date 26-10-2015

Tekening
Drawing

TOE PKN 103 130

Bodemplan *Groundplan*

Geleverde modules:

Zie tabel

Supplied modules:

See table

Montageinstructie:

- De modules kunnen correct geassembleerd worden met de voorgeboorde gaten.

Assembly instruction:

- The modules can be assembled correctly using the predrilled holes.

Montagevolgorde:

- 1 - Graaf de gaten volgens het bodemplan
- 2 - Assembleer en plaats bank
- 3 - Controleer of het toestel voldoet aan de afmetingen zoals op blad 'afmetingen'
- 4 - Dicht de gaten en verdicht het zand

Assembly sequence:

- 1 - Dig the holes according to the ground plan
- 2 - Assemble and place bench
- 3 - Check that the equipment conforms to the dimensions shown on sheet 'dimensions'
- 4 - Close the holes and compact the sand

Controles:

- 1 - Correcte opbouw en alle bevestigingsmiddelen

Checks:

- 1 - Correct assembly and all the fasteners

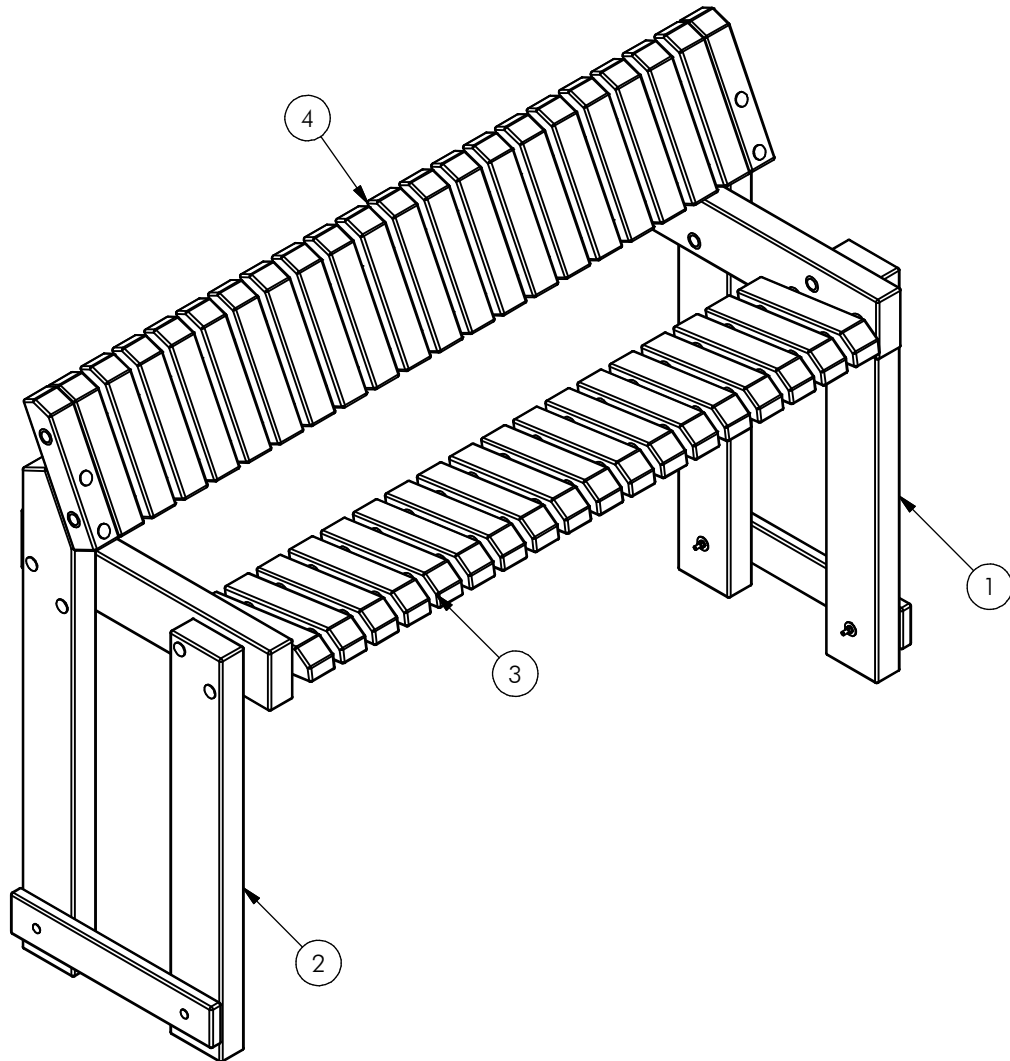

Nr	#	Type	Progr.	Volgnr	Bew.	Rev.	Benaming	Opmerking
1	1	MOD	PKN	103	130		Poot links	Parkbank
2	1	MOD	PKN	103	131		Poot rechts	Parkbank
3	1	MOD	PKN	103	132		Zitting	Parkbank
4	1	MOD	PKN	103	133		Rugleuning	Parkbank



Benaming
Title | Parkbank

Opmerking
Comment | Rebo

Datum
Date | 26-10-2015

Tekening
Drawing

TOE PKN 103 130

Modules Modules

PKNE103.130

Bench

LOGBOOK

(Onderstaand logboek kan gebruikt worden om te voldoen aan de eisen, gesteld in artikel 14 van het Warenwetbesluit Attractie- en Speeltoestellen)

Type indication	Streetfurniture
Product code	PKNE103.130
Name of equipment	PB Reboblokbank model 313
Maximum height of fall	n.a.
Year of construction	2017
Certificate	0183402366
inspection authority	NVT -
Name manufacturer	BOERplay Hyacintstraat 2 - 4255 HX Nieuwendijk Phone: +31 (0)183 40 23 66 Fax: +31 (0)183 40 35 64
name installer	_____ _____
Description of equipment	Bench
Location of equipment	_____
Data about the owner of the play equipment	
Name:	_____
Address:	_____
Postcode and town:	_____
Contact person:	_____
Telephone number:	_____
Data about the administrator of the play equipment	
Name:	_____
Address:	_____
Postcode and town:	_____
Contact person:	_____
Telephone number:	_____

LOGBOOK

Inspection and maintenance intervals



Nr.	Inspection	Maintenance	months between inspections
1	Verify equipment's stability, junctions and missing parts. Inspect bolts, screws and nuts for absence, jams, corrosion and wear.	Add missing parts, secure joints, apply missing fixing agent and replace corroded parts.	1
2	Check suspension for wear.	Replace worn parts and/or remove non-functioning parts.	1
3	Inspect rotating parts such as hinges, rolling-element bearings, etc. for wear and acceptability.	Replace worn parts and/or remove non-functioning parts.	1
4	Check wood for splinters, unacceptable damage and signs of rot. Especially at ground level.	Repair damage. Replace affected wood. Smoothen splintered wood and sharp edges.	1
5	Inspect foundation for stability, tearing and coverage.	Restore foundation and covering material.	3
6	Examine rubber and synthetic parts for wear, damage and break.	Replace original parts.	3
7	Inspect metal for corrosion and damage in the coating.	Restore any damaged coating (after removing rust and applying primer).	6
8	Check ropes, cables, chains and nets for wear and damage. Steel cables and nets which are tensioned must be checked for tension.	Replace parts where necessary. Steel cables and nets must be tensioned.	3
9	Inspect equipment for unsafe changes and additions.	Remove unsafe additions and correct unsafe changes.	1
10	Inspect safety surfaces.	Restore and repair where necessary.	1

Remarks

1. If used intensively, all points require extra attention.
2. Extreme weather conditions and locations may require a higher inspection frequency. Discuss this with the supplier.
3. Vandalism-sensitive locations require stricter inspections, possibly daily.
4. Check the terrain regularly for items that do not belong there, are unsafe or may be used wrongly. Examples are poisonous plants, glass shards, etc. Frequency depends on strain.
5. Remember that bad maintenance leads to unsafe conditions and notably faster impoverishment of the playground area.
6. Replacement parts can be ordered at the manufacturer with the part numbers on the module drawing. Drawings can be found in de user guide.
7. The impact area shall be provided with impact attenuating surface according to the specified falling height.
8. This list is conform the CEN-standard "playground equipment and surfacing NEN-EN 1176-7".



Dit toestel is geen speeltoestel conform het warenwetbesluit attractie- en speeltoestellen, en is dus niet als zodanig gecertificeerd.

This equipment is not playground equipment, so it has not been certified as such.



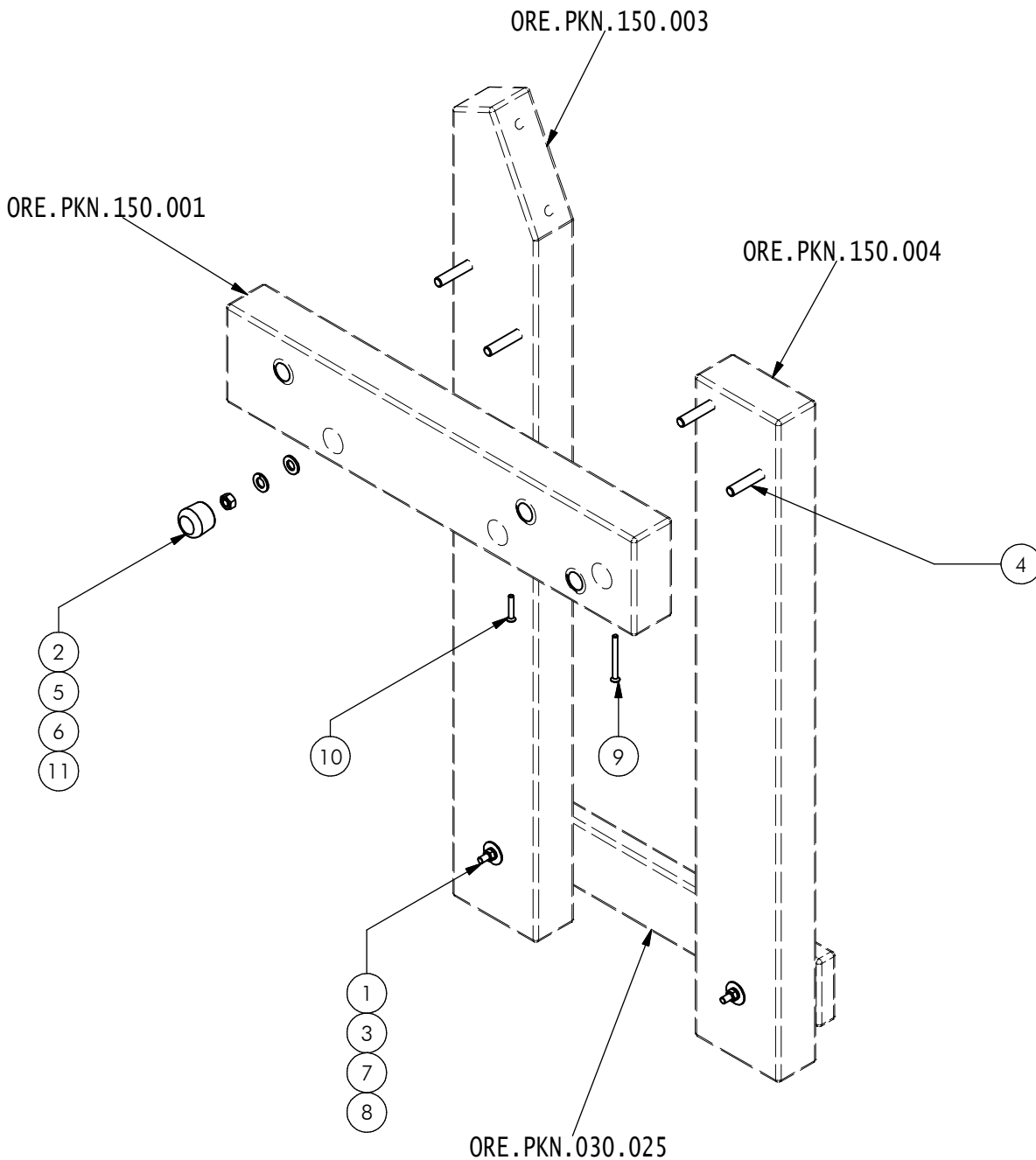

Nr	#	Type	Progr.	Volgnr	Bew.	Rev.	Benaming	Opmerking
1	2	BSV	017	008	006		Zeskantmoer	M8 - VZ 8.8
2	4	BSV	017	012	010		Zeskantmoer	M12 - VZ 8.8
3	2	BSV	026	008	120		Slotbout	M8 x 120 - VZ 8.8
4	4	BSV	026	012	120		Slotbout	M12 x 120 - VZ 8.8
5	4	BSV	030	012	003		Sluistring	M12 - VZ 8.8
6	4	BSV	032	012	002		Veerring	M12 - VZ 8.8
7	2	BSV	034	008	002		Veerring	M8 - VZ 8.8
8	2	BSV	035	008	030		CARROSSERIERING	M8 x 30 - VZ 8.8
9	1	BSV	071	006	065		Metaalschroef	M6 x 65 - VZ 8.8
10	1	BSV	071	006	035		Metaalschroef	M6 x 35 - VZ 8.8
11	4	KST	DOP	036	090		Meubeldop	Rond 36



Benaming Title Poot links
 Opmerking Comment Parkbank
 Datum Date 23-10-2015

Tekening Drawing

MOD PKN 103 130

Samenstelling module Assembly module

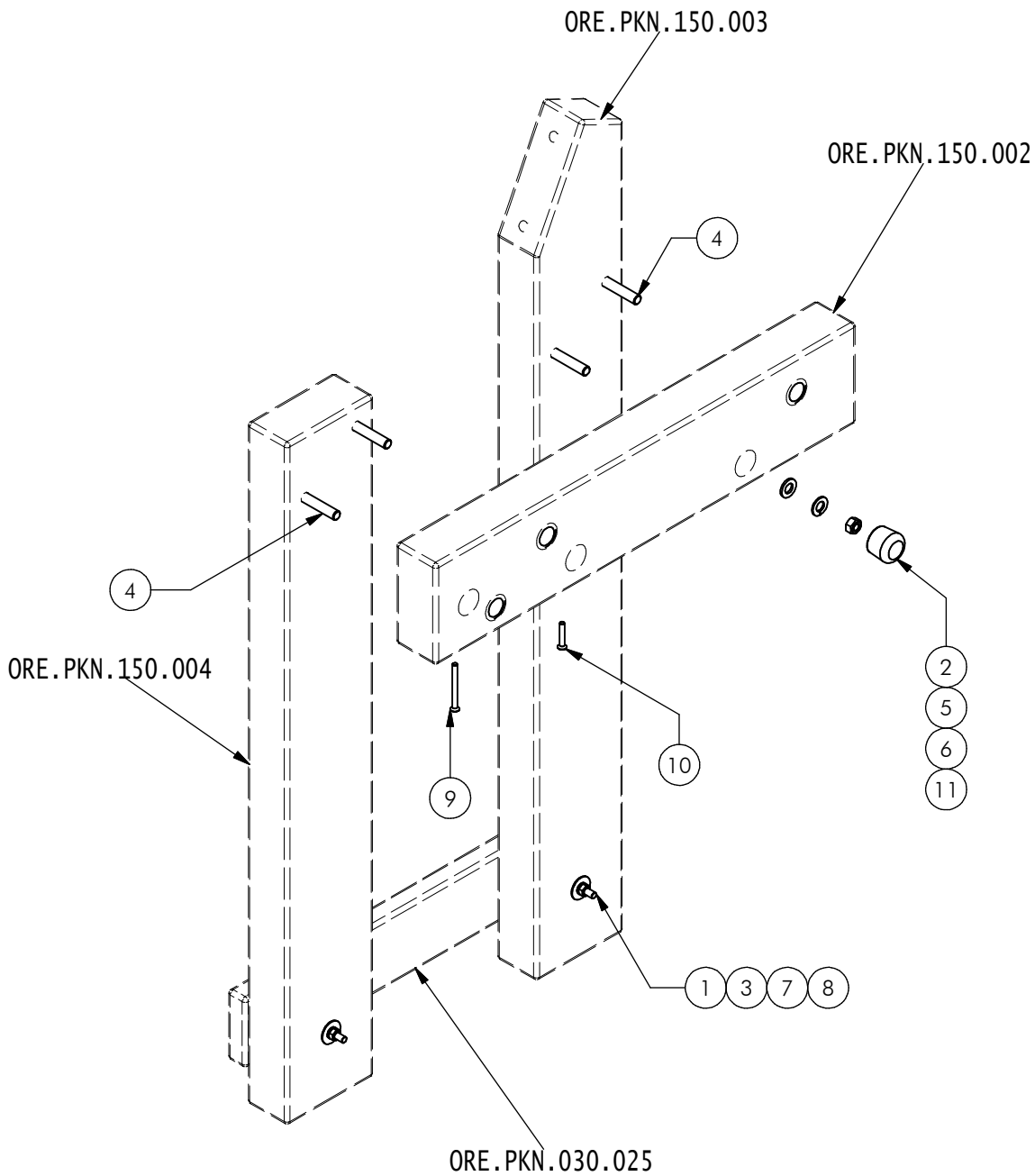

Nr	#	Type	Progr.	Volgnr	Bew.	Rev.	Benaming	Opmerking
1	2	BSV	017	008	006		Zeskantmoer	M8 - VZ 8.8
2	4	BSV	017	012	010		Zeskantmoer	M12 - VZ 8.8
3	2	BSV	026	008	120		Slotbout	M8 x 120 - VZ 8.8
4	4	BSV	026	012	120		Slotbout	M12 x 120 - VZ 8.8
5	4	BSV	030	012	003		Sluitring	M12 - VZ 8.8
6	4	BSV	032	012	002		Veerring	M12 - VZ 8.8
7	2	BSV	034	008	002		Veerring	M8 - VZ 8.8
8	2	BSV	035	008	030		CARROSSERIERING	M8 x 30 - VZ 8.8
9	1	BSV	071	006	065		Metaalschroef	M6 x 65 - VZ 8.8
10	1	BSV	071	006	035		Metaalschroef	M6 x 35 - VZ 8.8
11	4	KST	DOP	036	090		Meubeldop	Rond 36



Benaming Title Poot rechts
 Opmerking Comment Parkbank
 Datum Date 23-10-2015

Tekening Drawing

MOD PKN 103 131

Samenstelling module Assembly module

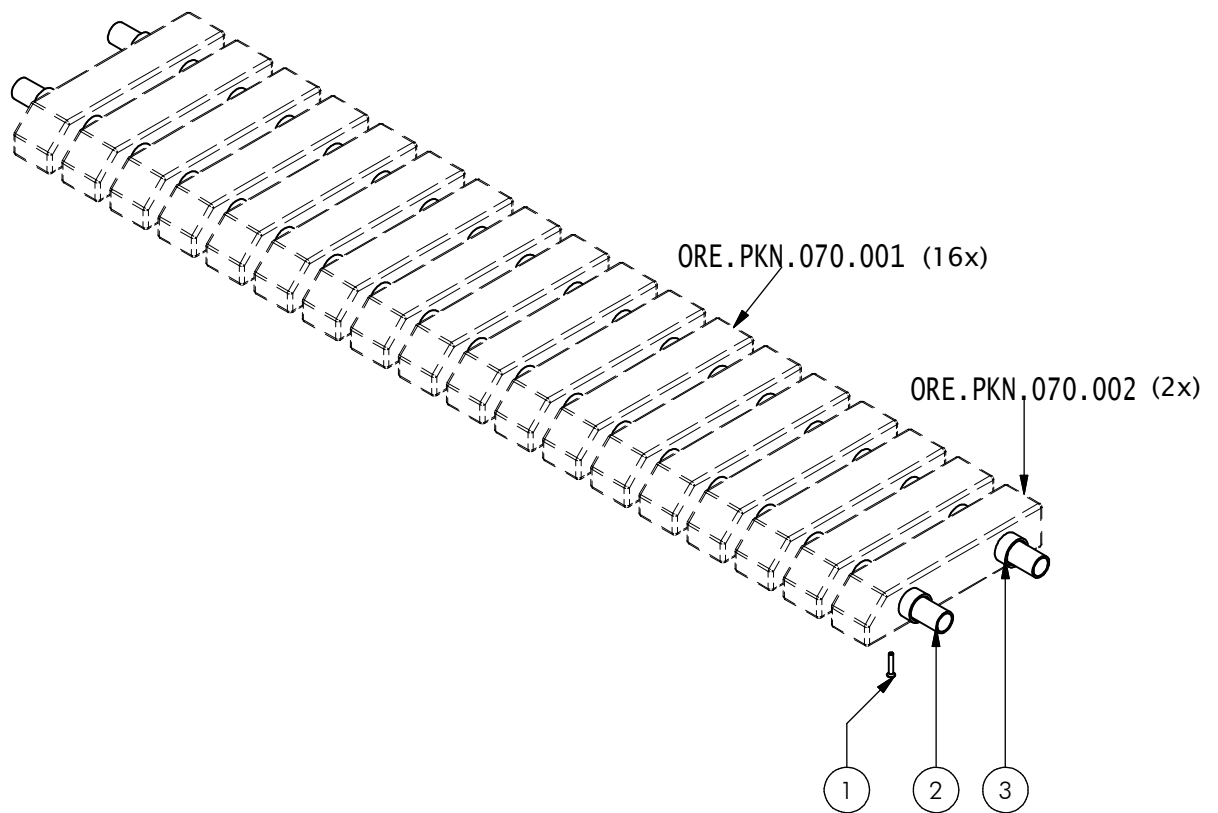

Nr	#	Type	Progr.	Volgnr	Bew.	Rev.	Benaming	Opmerking
1	4	BSV	071	006	035		Metaalschroef	M6 x 35 - VZ 8.8
2	2	OME	318	173	372		Buis 31.8x2.6	L= 1730 mm
3	38	OME	PKN	076	906		Buis 42x36	L= 20 mm



Benaming / Title: Zitting
 Opmerking / Comment: Parkbank
 Datum / Date: 23-10-2015

Tekening / Drawing

MOD PKN 103 132

Samenstelling module *Assembly module*

ORE.PKN.070.003 (2x)

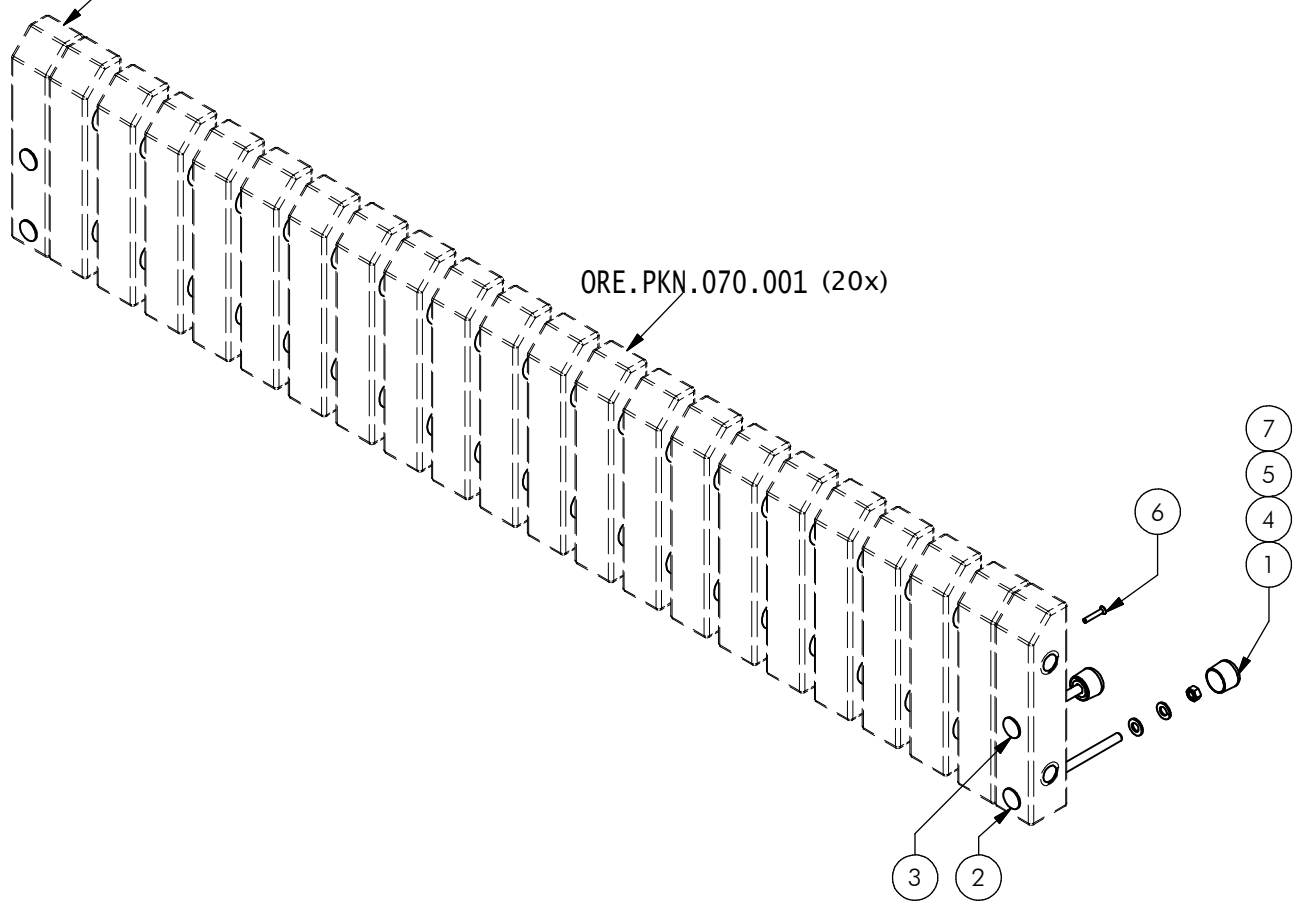

Nr	#	Type	Progr.	Volgnr	Bew.	Rev.	Benaming	Opmerking
1	4	BSV	017	012	010		Zeskantmoer	M12 - VZ 8.8
2	2	BSV	026	012	200		Slotbout	M12 x 200 - VZ 8.8
3	2	BSV	026	012	140		Slotbout	M12 x 140 - VZ 8.8
4	4	BSV	030	012	003		Sluitring	M12 - VZ 8.8
5	4	BSV	032	012	002		Veerring	M12 - VZ 8.8
6	4	BSV	071	006	035		Metaalschroef	M6 x 35 - VZ 8.8
7	8	KST	DOP	036	090		Meubeldop	Rond 36
8	2	OME	318	188	372		Buis 31.8x2.6	L= 1880 mm
9	38	OME	PKN	076	906		Buis 42x36	L= 20 mm



Benaming Title Rugleuning
 Opmerking Comment Parkbank
 Datum Date 26-10-2015

Tekening Drawing

MOD PKN 103 133

Samenstelling module *Assembly module*