

# Outdoor Trampoline

1M-T100S

Data sheet  
Karta katalogowa  
Scheda di dati  
Fiche Technique  
Datenblatt

**:UNIPLAYGROUNDS**  
bezpieczne nawierzchnie

## EN Outdoor vandal-proof trampoline

### Description:

An outdoor trampoline is a vandal proof, digged into the ground device. The trampoline a single person use instrument, designed for adults and children use in public space e.g. schools, playgrounds, country parks and leisure centres, for all year round use. The jumping mat is made of a special, anti slip plastic blocks and is weather-resistant.

**Device size:** 155x155x45 cm; Jumping mat size: 105x105 cm;

**Training effect:** Jumping on the trampoline is a general development activity. It engages and activates whole body muscles, improving coordination, sense of balance, endurance, flexibility, and blood circulation. This motor efficiencies are necessary for the proper children development and for adults can be even a great way to reduce the weight.

### Method of use:

Carefully come on the center of the jumping mat and start to jump using both your legs.

**Exercise difficulty:** Easy

Full safety of the equipment use can be maintained only as a result of regular control concerning damage and wear. Devices should be regularly checked for security and functionality.

The devices can be used by children from 5 years of age. Children should be supervised by guardians.

Intended for one person. Maximum weight of user 120 kg.

Prepared on the basis of the following standards: PN-EN 1176-1:2009, PN-EN 16-630:2015.

Manufactured in Poland.

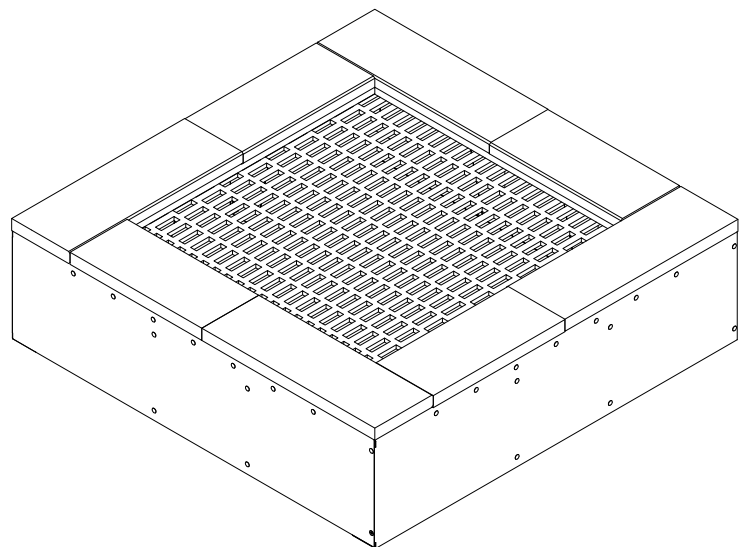
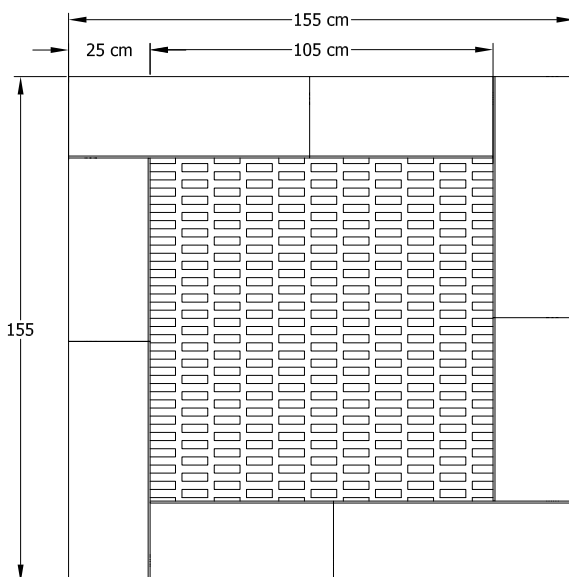

**UNIPLAYGROUNDS, Wojciech Myszkowski**  
71-075 Szczecin, ul. Fieldorfa 2b lok. 10  
+48 605 21 77 21, [info@uniplaygrounds.pl](mailto:info@uniplaygrounds.pl)

# Outdoor Trampoline

1M-T100S

**:UNIPLAYGROUNDS**  
bezpieczne nawierzchnie

EN

**A inspection is carried out as follows:**

**Routine inspection:**

Visual inspection device is intended to detect visible damage and risks that could arise for reasons such as: misuse, vandalism or weather conditions.

NOTE 1 For outdoor fitness installed in areas with intensive use of equipment, and also in areas characterized to frequent damage caused by vandalism, may be required daily inspection.

NOTE 2 During the inspection routine and operational should pay attention to: cleanliness, level ground state of the ground, exposed (mobile) foundations, sharp edges, missing parts, excessive used (mobile and disperse the parts), structural strength of construction.

**Operational control:**

More accurate than a routine inspection of facilities for checking the functionality and stability of exercise equipment. You should do this every 1 to 3 months according to guidance of manufacturer.

**Main annual inspection:**

Control of defining the overall condition for safe exploiting of equipment (main annual review).

NOTE 3 Main annual inspection may need to dig or decompose (spin) of individual equipment or their parts.

The annual inspection should be performed by the manufacturer or an authorized repairer 1-MOVE. Submissions annual inspection the following address:

1@1move.pl

**Failures**

In the absence of damage or exploiting of the device must be immediately replaced or repaired. If this is not possible, secure the unit before use. Contact the site 1-MOVE Center: 1@1move.pl.

Use only original spare parts. Repair and replacement of parts may only make the manufacturer or its authorized representative.

# Outdoor Trampoline

1M-T100S

**:UNIPLAYGROUNDS**

bezpieczne nawierzchnie

Impact Area

Strefa upadku

Zone d'Impact

Area de Impacto

Fallaum

**20,5 m<sup>2</sup>**

Required surface: Any

Wymagana nawierzchnia: dowolna

Toute surface nécessaire

Superficie necessaria: Qualsiasi

Erforderliche Oberflächen: Jede

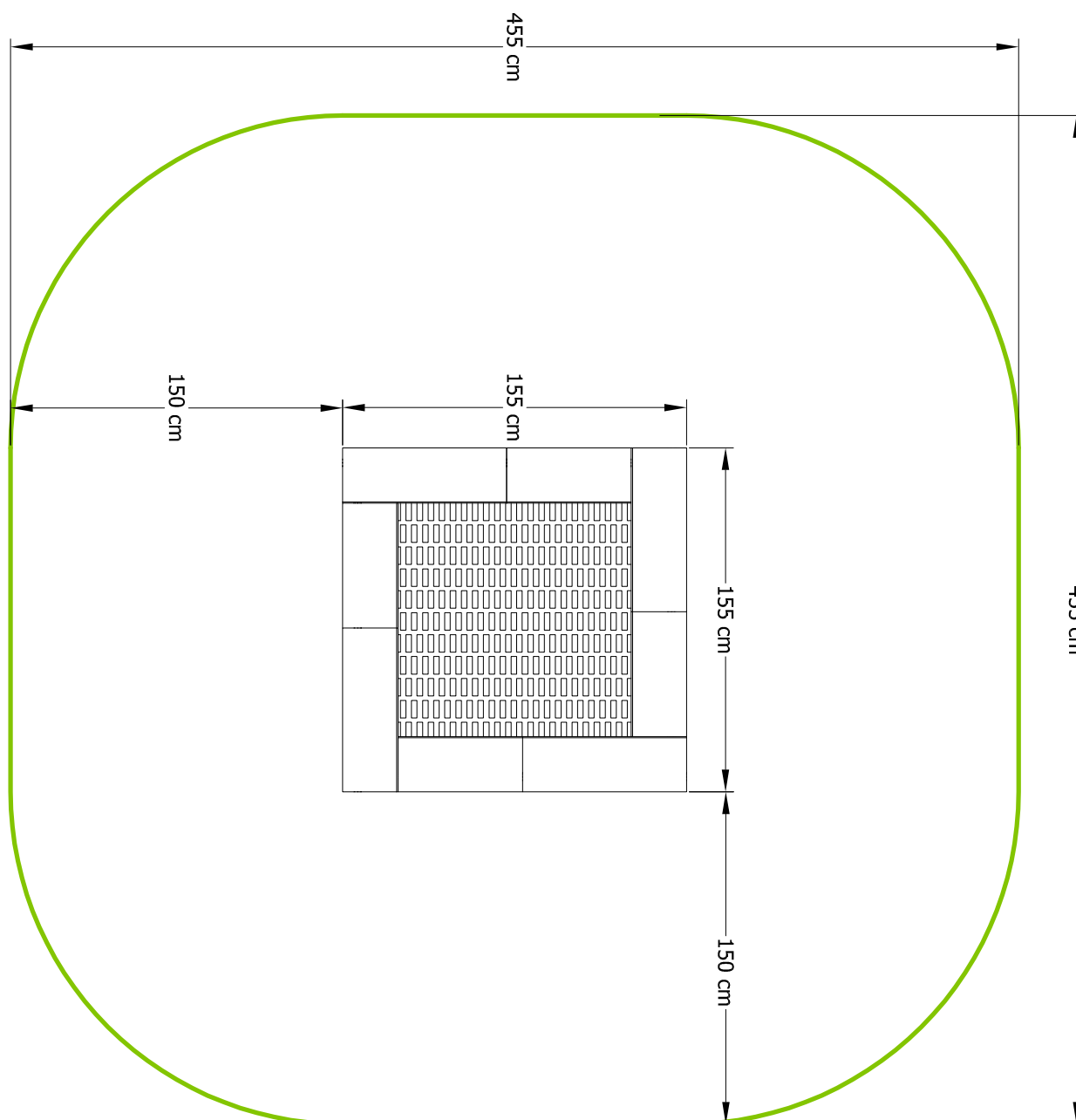

UNIPLAYGROUNDS, Wojciech Myszkowski  
71-075 Szczecin, ul. Fieldorfa 2b lok. 10  
+48 605 21 77 21, [info@uniplaygrounds.pl](mailto:info@uniplaygrounds.pl)

# Outdoor Trampoline

1M-T100S

**:UNIPLAYGROUNDS**

bezpieczne nawierzchnie

Footing plan  
Plan fundamentowania  
Implanation  
Implanación  
Fundamentplan

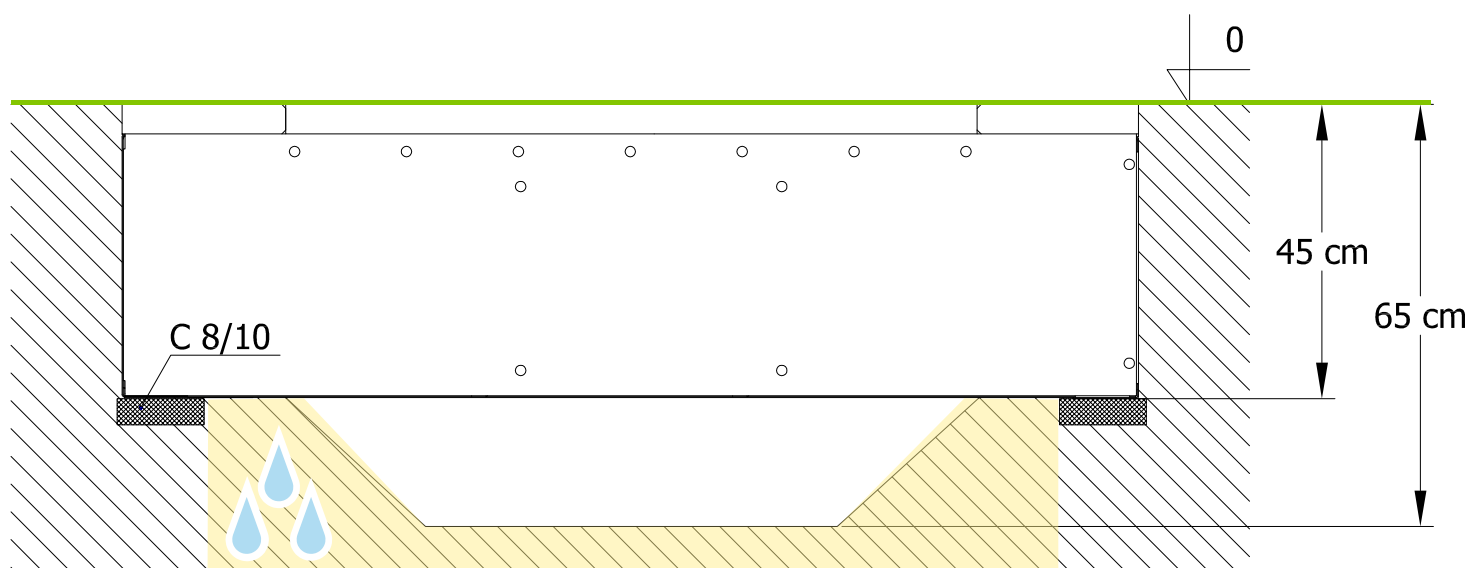

Drained undersoil / Podłoże wodoprzepuszczalne / Дренажная подсыпь

**UNIPLAYGROUNDS, Wojciech Myszkowski**  
71-075 Szczecin, ul. Fieldorfa 2b lok. 10  
+48 605 21 77 21, [info@uniplaygrounds.pl](mailto:info@uniplaygrounds.pl)