

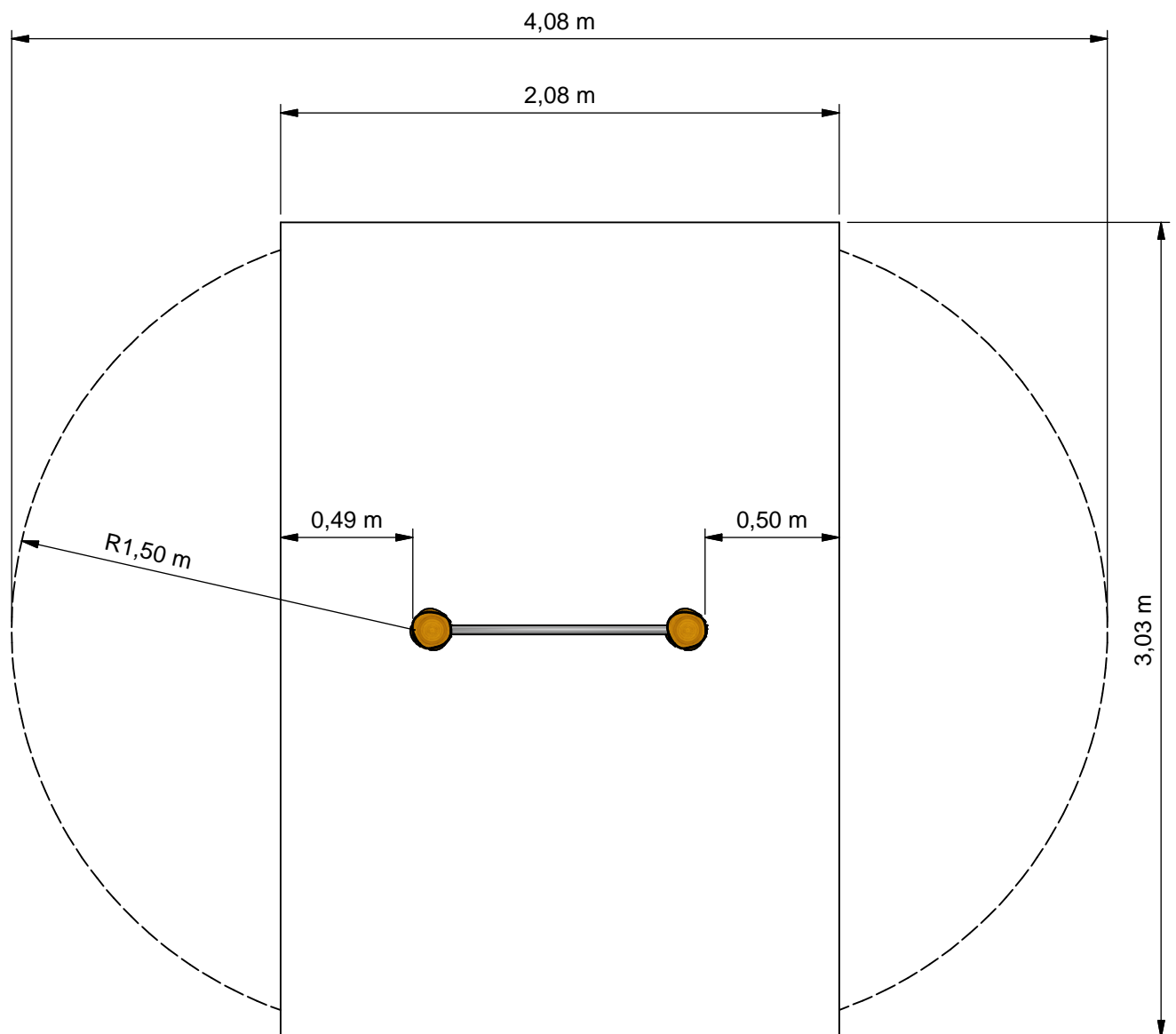

Tumble bar solo



PSTE000.080



- Obstakelvrij EN-1176**
- Obstacle free EN-1176*
- Opvangzone**
- Impact area*
- Obstakelvrij WAS**
- Obstacle free WAS*



Benaming
Title Duikelrek

Opmerking
Comment Solo

Datum
Date 27-1-2017

Tekening
Drawing

TOE PST 000 080

Obstakelvrije zone *Obstacle free zone*

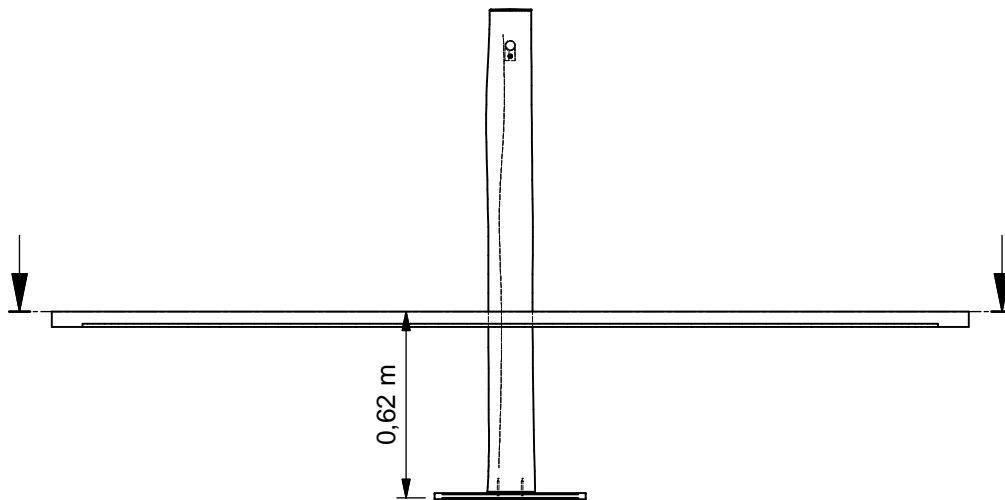
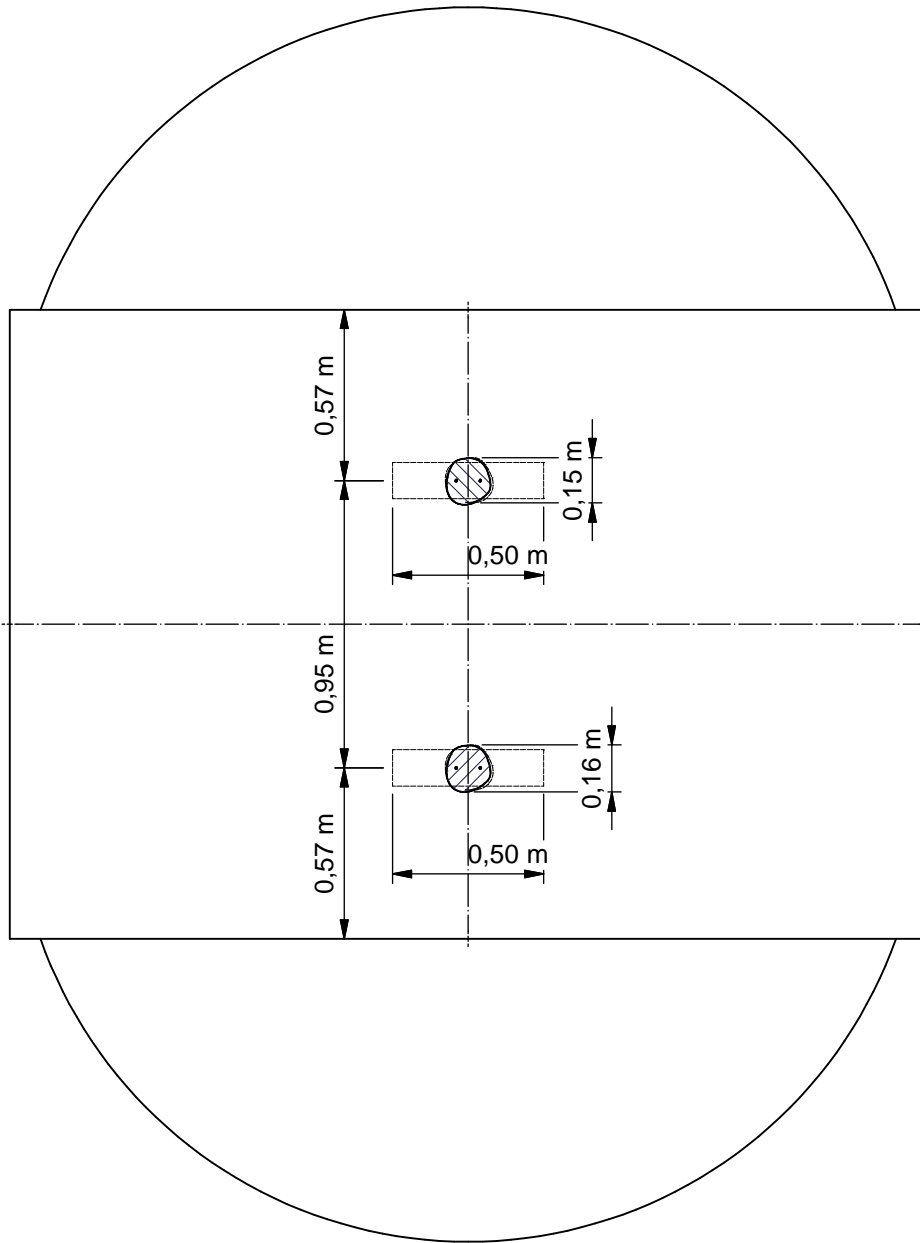

Benaming
 Title Duikelrek
 Opmerking
 Comment Solo
 Datum
 Date 27-1-2017

Tekening
 Drawing

TOE PST 000 080

Bodemplan *Groundplan*

Staanders afvlakken zodat kopplaat duikelstang geheel tegen staander komt. Uitstekende delen < 8 mm. (2x)

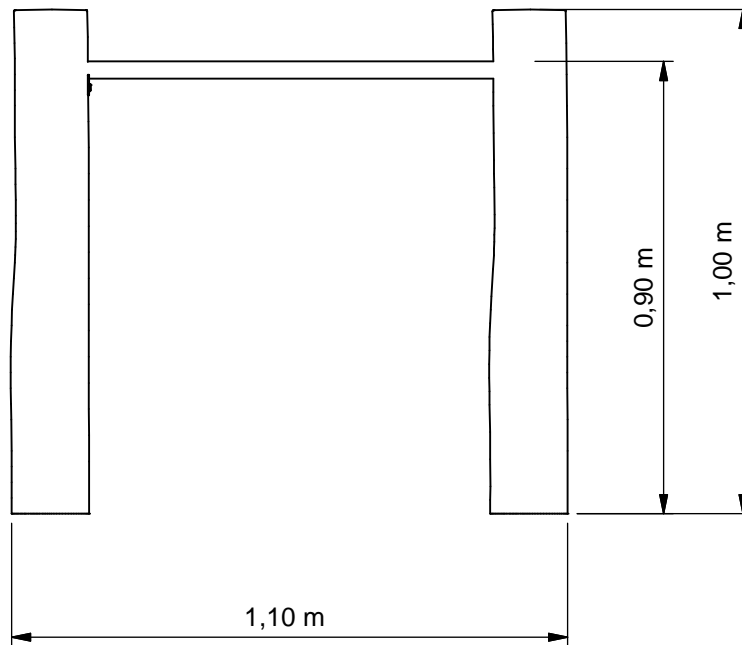
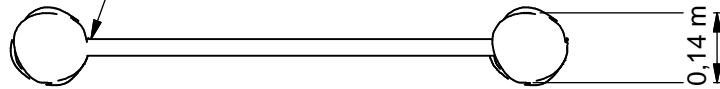

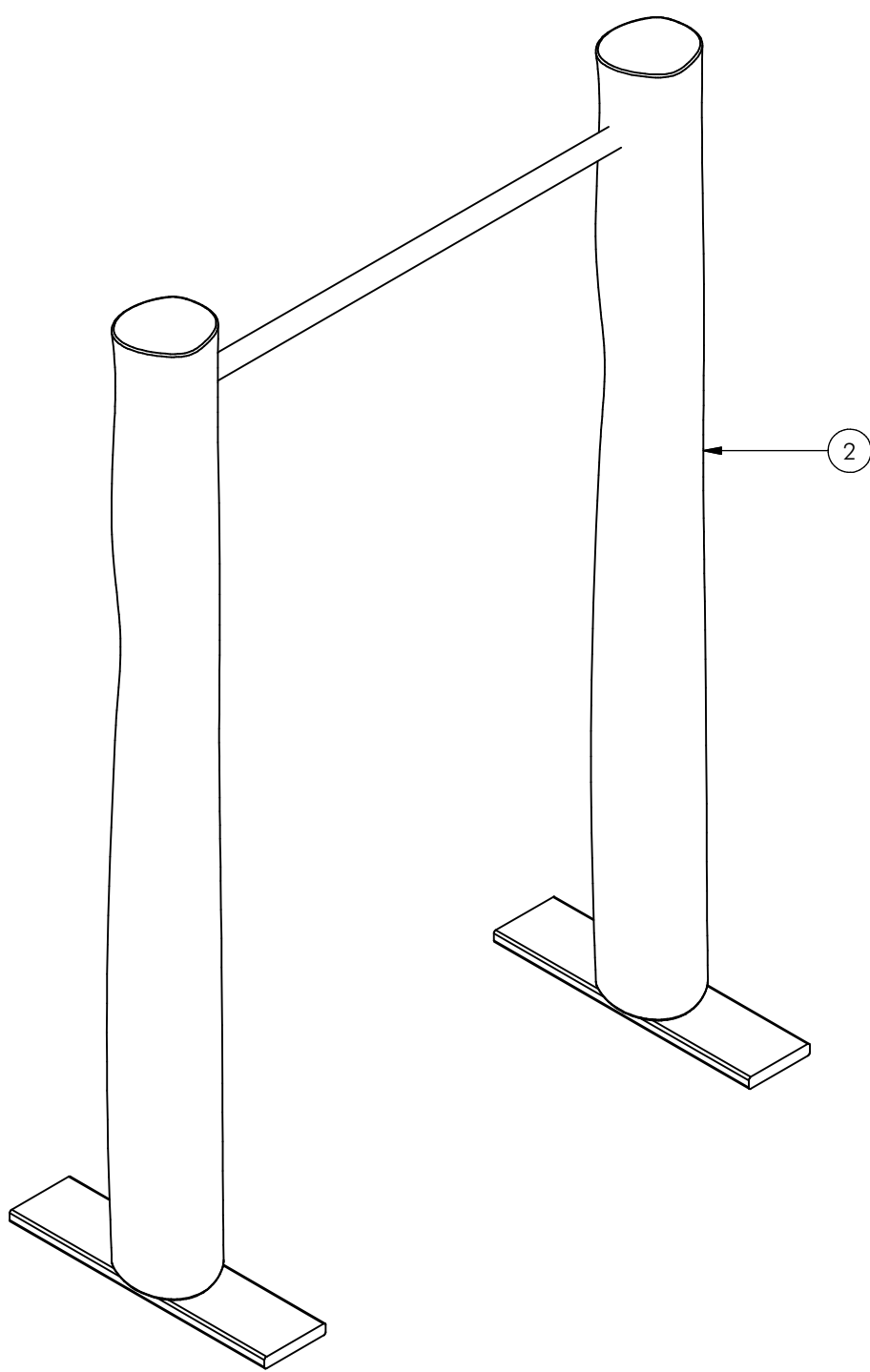

Nr	#	Type	Progr.	Volgnr	Bew.	Rev.	Benaming	Opmerking
1	1	MOD	PST	007	008	B	Duikel	Rek H=900
2	1	MOD	PST	007	010	A	Duikel	Paal H=900



Benaming
Title Duikelrek

Opmerking
Comment Solo

Datum
Date 27-1-2017

Tekening
Drawing

TOE PST 000 080

Modules Modules

Geleverde delen:

- A - 2x staander met voetplaat 1,6x0,3x0,3 m [20 kg]
 B - duikelstang 0,8x0,1x0,1 m [2 kg]

Bevestiging sets:

- 1 - 2 schroeven 5x50 met ring (2 stuks)

Montagevolgorde:

- 1 - graaf de gaten volgens het bodemplan en plaats hierin de staanders
- 2 - monteer de stang met de bevestiging sets op de aangegeven hoogte
- 3 - controleer of het toestel voldoet aan de afmetingen zoals op blad 'afmetingen'
- 4 - dicht de gaten en verdicht het zand

Controles:

- 1 - correcte opbouw en alle bevestigingsmiddelen
- 2 - de hoogte van de stang (90 cm)
- 3 - controleer de afmetingen van de valbodem t.o.v. het toestel

Supplied parts:

- A - 2x post with footplate 1,6x0,3x0,3 m [20 kg]
 B - tumble bar 0,8x0,1x0,1 m [2 kg]

Mounting kits:

- 1 - 2x 5x50 screws with washers (2 pcs)

Assembly sequence:

- 1 - dig the holes according to the ground plan and place the play equipment
- 2 - fix the bar between the posts with mounting kits 1
- 3 - check that the equipment conforms to the dimensions shown on sheet 'dimensions'
- 4 - close the holes and compact the sand

Checks:

- 1 - correct assembly and all the fasteners
- 2 - the height of the bar (90 cm)
- 3 - check the dimensions of the safety area compared to the play equipment

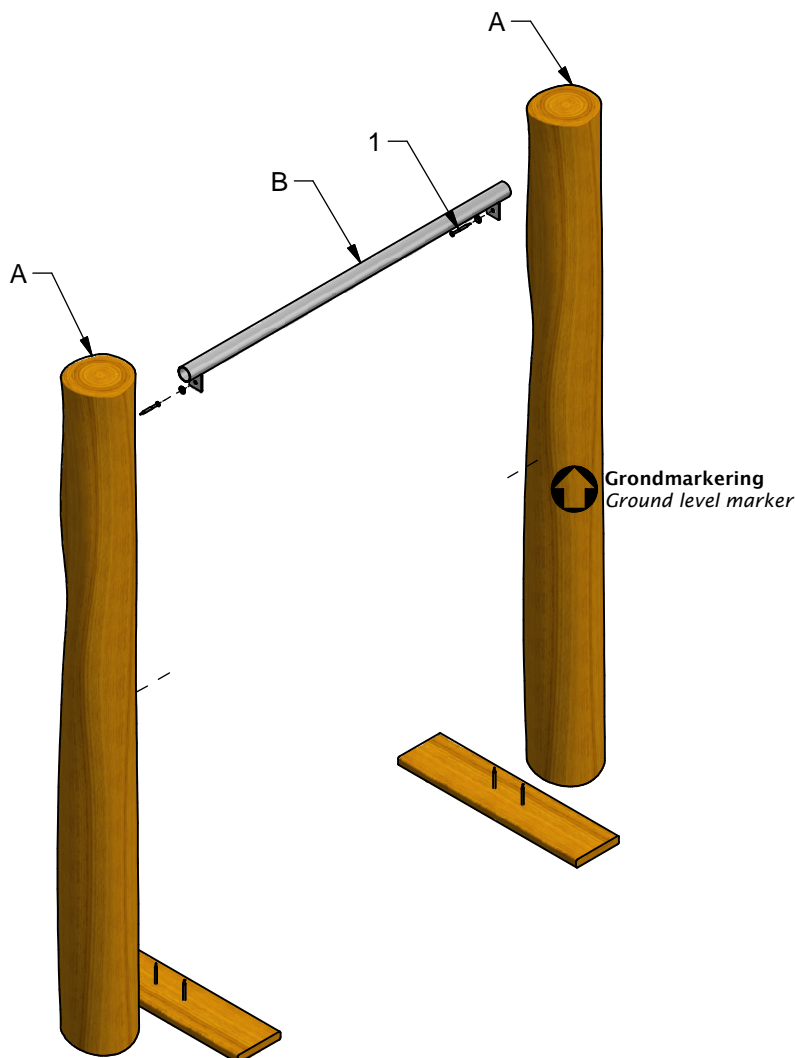

PSTE000.080

Tumble bar solo

LOGBOOK

(Onderstaand logboek kan gebruikt worden om te voldoen aan de eisen, gesteld in artikel 14 van het Warenwetbesluit Attractie- en Speeltoestellen)

Type indication	Adventure Play
Product code	PSTE000.080
Name of equipment	Duikel solo
Maximum height of fall	0,9 m
Year of construction	2017
Certificate	031066
inspection authority	TUV Nederland QA BV De Waal 21c, Best - 5684 PH Best
Name manufacturer	BOERplay Hyacintstraat 2 - 4255 HX Nieuwendijk Phone: +31 (0)183 40 23 66 Fax: +31 (0)183 40 35 64
name installer	_____ _____
Description of equipment	Tumble bar solo
Location of equipment	_____
Data about the owner of the play equipment	
Name:	_____
Address:	_____
Postcode and town:	_____
Contact person:	_____
Telephone number:	_____
Data about the administrator of the play equipment	
Name:	_____
Address:	_____
Postcode and town:	_____
Contact person:	_____
Telephone number:	_____

LOGBOOK

Inspection and maintenance intervals



Nr.	Inspection	Maintenance	months between inspections
1	Verify equipment's stability, junctions and missing parts. Inspect bolts, screws and nuts for absence, jams, corrosion and wear.	Add missing parts, secure joints, apply missing fixing agent and replace corroded parts.	1
2	Check suspension for wear.	Replace worn parts and/or remove non-functioning parts.	1
3	Inspect rotating parts such as hinges, rolling-element bearings, etc. for wear and acceptability.	Replace worn parts and/or remove non-functioning parts.	1
4	Check wood for splinters, unacceptable damage and signs of rot. Especially at ground level.	Repair damage. Replace affected wood. Smoothen splintered wood and sharp edges.	1
5	Inspect foundation for stability, tearing and coverage.	Restore foundation and covering material.	3
6	Examine rubber and synthetic parts for wear, damage and break.	Replace original parts.	3
7	Inspect metal for corrosion and damage in the coating.	Restore any damaged coating (after removing rust and applying primer).	6
8	Check ropes, cables, chains and nets for wear and damage. Steel cables and nets which are tensioned must be checked for tension.	Replace parts where necessary. Steel cables and nets must be tensioned.	3
9	Inspect equipment for unsafe changes and additions.	Remove unsafe additions and correct unsafe changes.	1
10	Inspect safety surfaces.	Restore and repair where necessary.	1

Remarks

1. If used intensively, all points require extra attention.
2. Extreme weather conditions and locations may require a higher inspection frequency. Discuss this with the supplier.
3. Vandalism-sensitive locations require stricter inspections, possibly daily.
4. Check the terrain regularly for items that do not belong there, are unsafe or may be used wrongly. Examples are poisonous plants, glass shards, etc. Frequency depends on strain.
5. Remember that bad maintenance leads to unsafe conditions and notably faster impoverishment of the playground area.
6. Replacement parts can be ordered at the manufacturer with the part numbers on the module drawing. Drawings can be found in de user guide.
7. The impact area shall be provided with impact attenuating surface according to the specified falling height.
8. This list is conform the CEN-standard "playground equipment and surfacing NEN-EN 1176-7".

Warenwet

Certificaat van Typeonderzoek Type Examination Certificate

afgegeven door issued by

TÜV Nederland QA BV



aangewezen bij ministeriële beschikking van
4 mei 2012, nr. VGP 3113590

commissioned by departmental order
of 4 May 2012, no. VGP 3113590

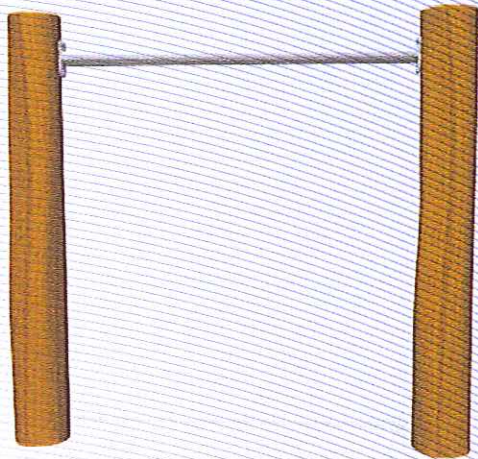
Certificaat nr. Certificate nr.	031066TA_20121005	Dossiernr. File nr.	031066TA
Productomschrijving Product description	Duikelrek Solo		
Evt. nadere aanduidingen Further indications	Hoogte 1 meter		
voor nadere informatie zie bijbehorend rapport met gelijkkluidend dossiernr. for further information see associated report with identical file nr.			
Eigenaar / certificaathouder en adres Owner/certificate holder and address	Boer Speeltoestellen BV Postbus 10 4255 ZG NIEUWENDIJK		
Soort toestel Category of equipment	speeltoestel		
Fabrikant Manufacturer	Boer Speeltoestellen BV Postbus 10 4255 ZG NIEUWENDIJK		
Type/Serienummer Type/Serial number	PST.000.080 /	in te vullen door de fabrikant to be filled out by the manufacturer	
Jaar van fabricage Year of construction	vanaf 2012 since		
Leverancier Supplier	Boer Speeltoestellen BV Postbus 10 4255 ZG NIEUWENDIJK		
Jaar van leverantie Year of supply	in te vullen door de leverancier to be filled out by the supplier		
Datum keuring Date of examination	06-07-2012 – 05-10-2012		

TÜV Nederland QA BV, de Waal 21C, NL-5684 PH Best verklaart, dat het bovenaangehaalde toestel voldoet aan de vervaardigingvoorschriften genoemd in het Warenwetbesluit attractie- en speeltoestellen (met als leidraad de normatieve documenten NEN-EN 1176:2008).

TÜV Nederland QA BV declares that the here above mentioned equipment meets the safety and health requirements mentioned in the Dutch law "Warenwetbesluit attractie- en speeltoestellen" (guided by normative documents EN 1176:2008).

Namens het bestuur, For the board, A.C. Boon Directeur	
---	--

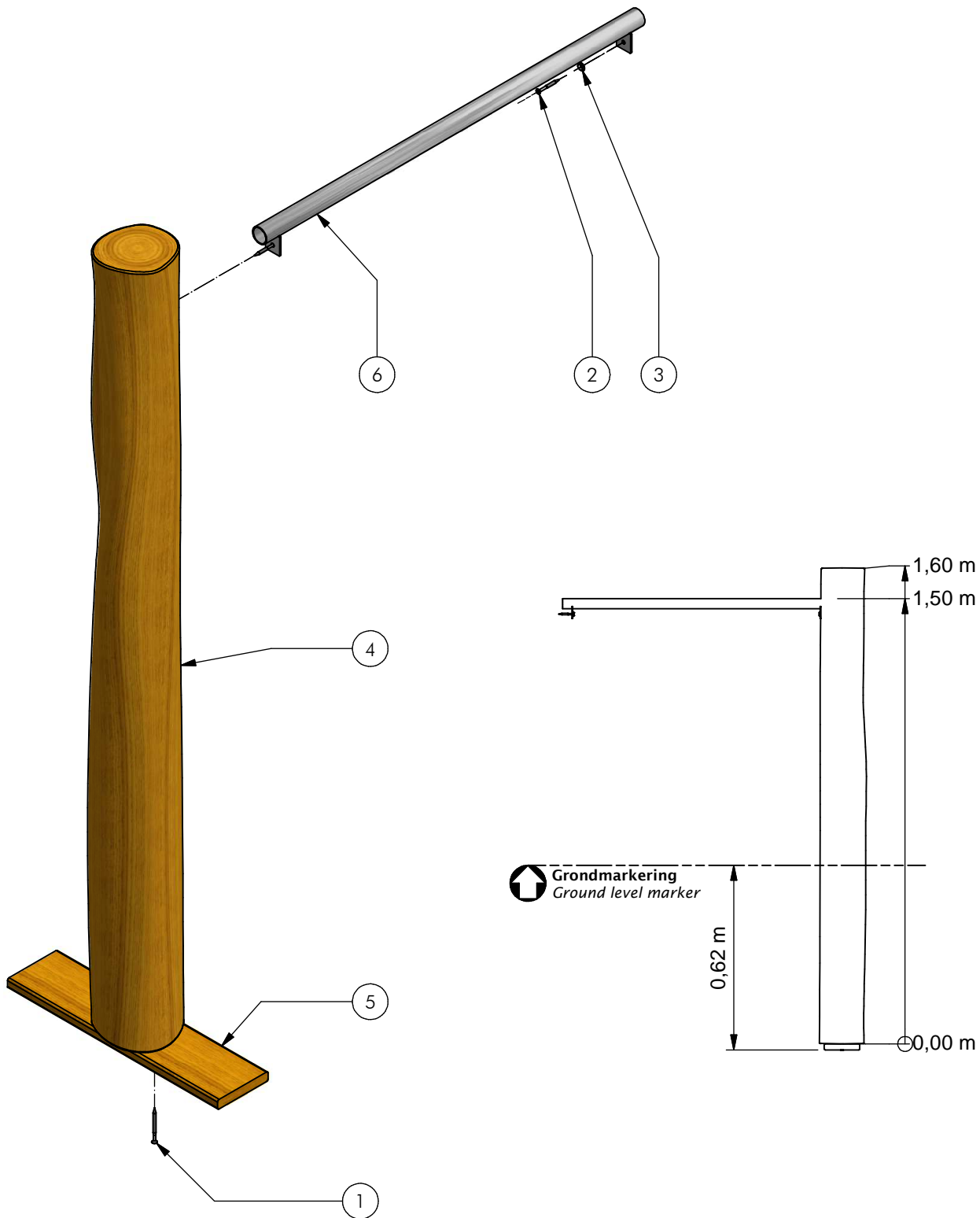

Nr	#	Type	Progr.	Volgnr	Bew.	Rev.	Benaming	Opmerking
1	2	BSR	002	005	070		Schroef Assy	5 x 70 - RVS A2-70
2	2	BSR	002	005	050		SCHROEF	5 x 50
3	2	BSR	036	005	015		Facet ring	M5 - RVS A2-70
4	1	OHO	PST	160	016		Paal 14-16	Lengte =1600
5	1	OHO	PST	230	050		Plank 120x20	Lengte = 500
6	1	SME	PST	076	320	A	Duikelbuis	Adventure Play



Benaming
Title Duikel

Opmerking
Comment Rek H=900

Datum
Date 23-4-2015

Tekening
Drawing

MOD PST 007 008 B
 Samenstelling module Assembly module

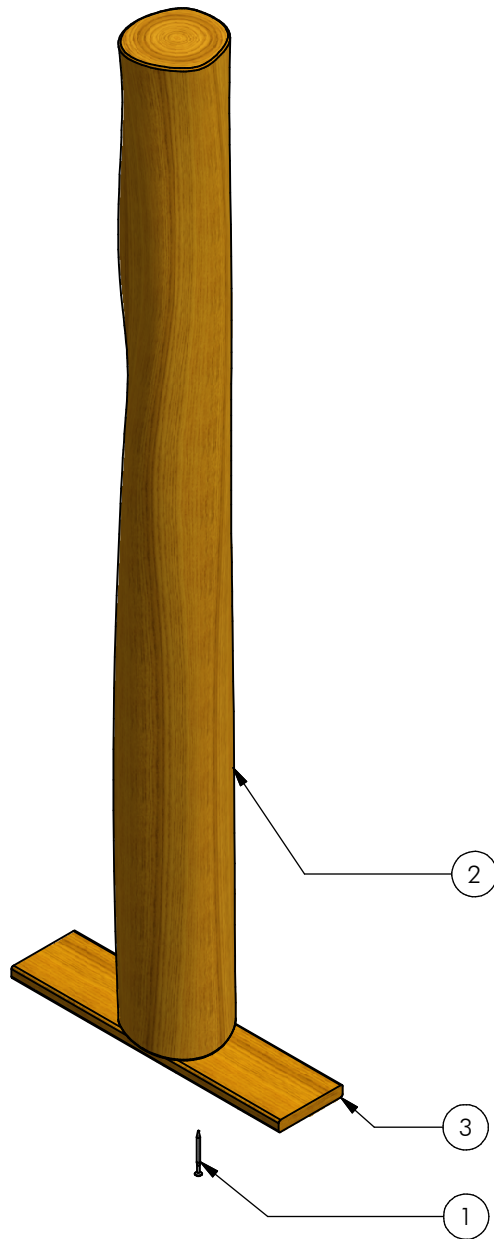

Nr	#	Type	Progr.	Volgnr	Bew.	Rev.	Benaming	Opmerking
1	2	BSR	002	005	070		Schroef Assy	5 x 70 - RVS A2-70
2	1	OHO	PST	160	016		Paal 14-16	Lengte =1600
3	1	OHO	PST	230	050		Plank 120x20	Lengte = 500



Benaming
Title: Duikel

Opmerking
Comment: Paal H=900

Datum
Date: 8-4-2015

Tekening
Drawing

MOD PST 007 010 A
 Samenstelling module *Assembly module*